

Gewichtsoptimierter Materialmix:
Verwindungssteife Struktur mit nur
241 Kilogramm Gewicht

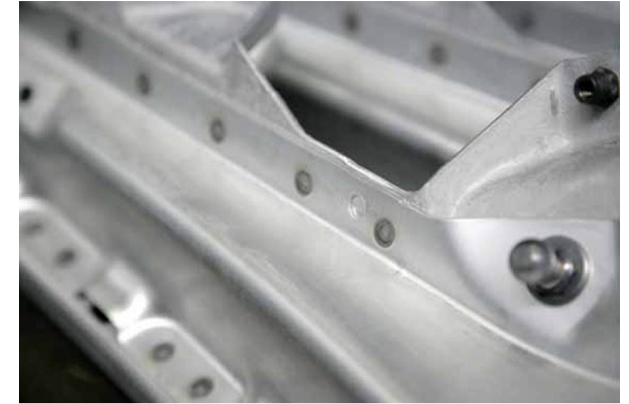

BONDING & RIVET

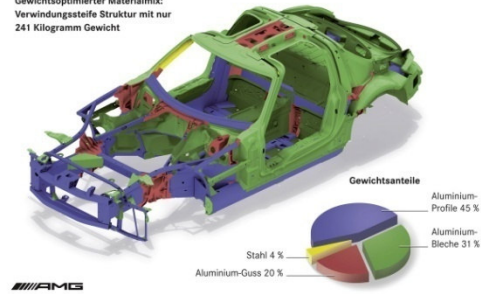

ALUMINIUM BODY REPAIR

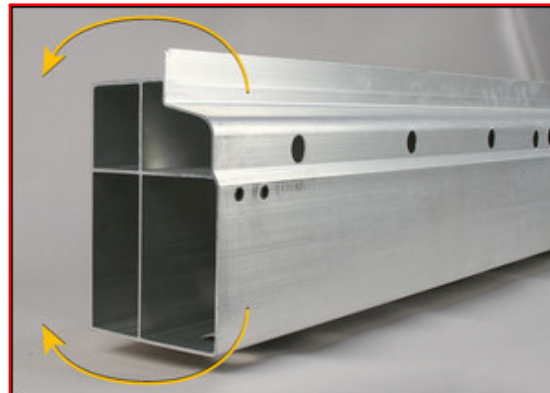



Riveted casting for front strut tower on new Jaguar XK sports car



SPEED HUNTERS DINO DALLE CARBONARE





Bonding Adhesive

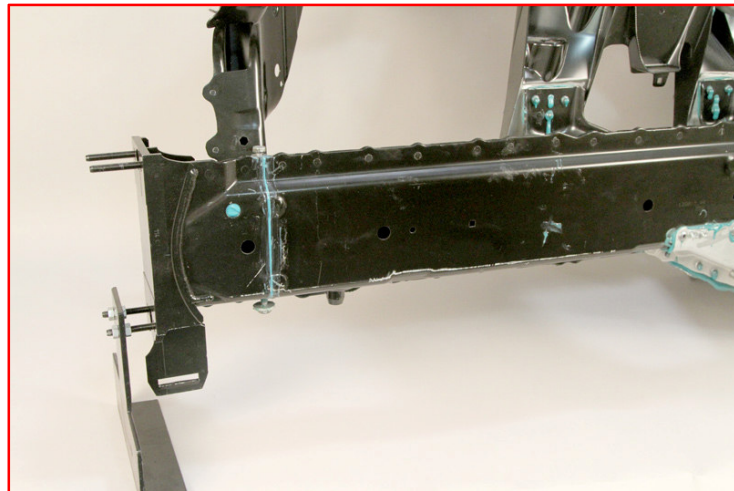

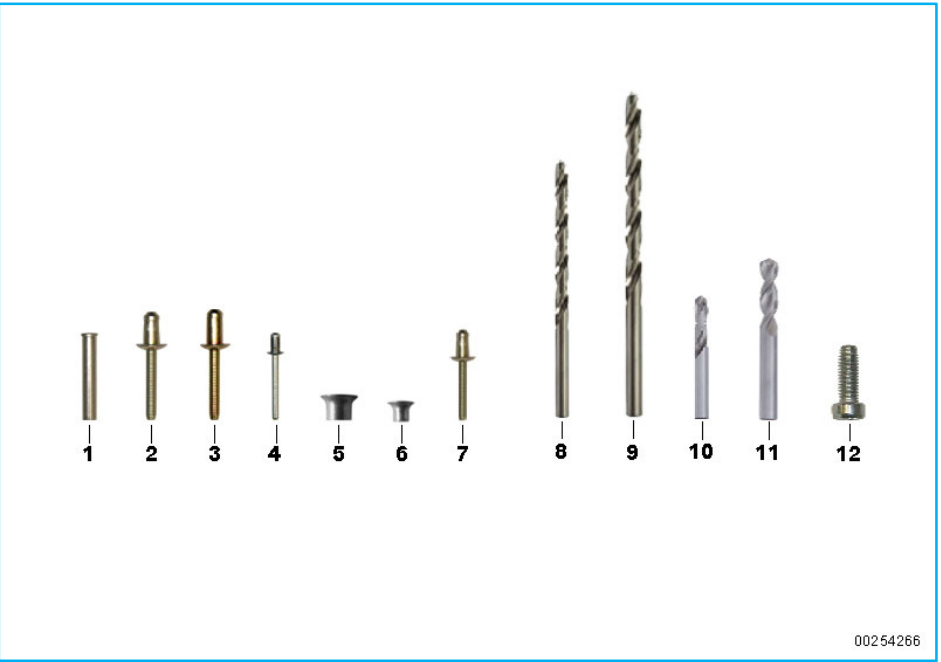
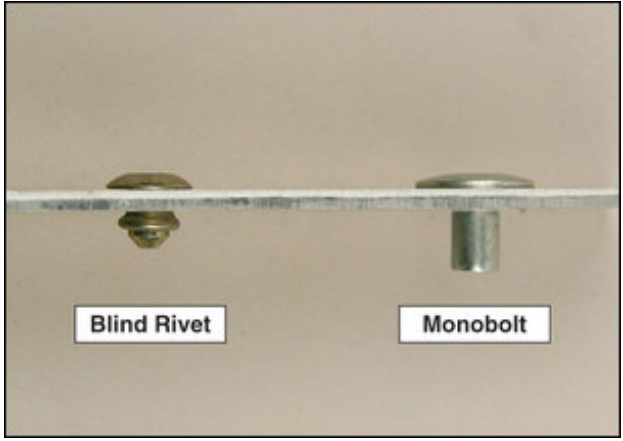
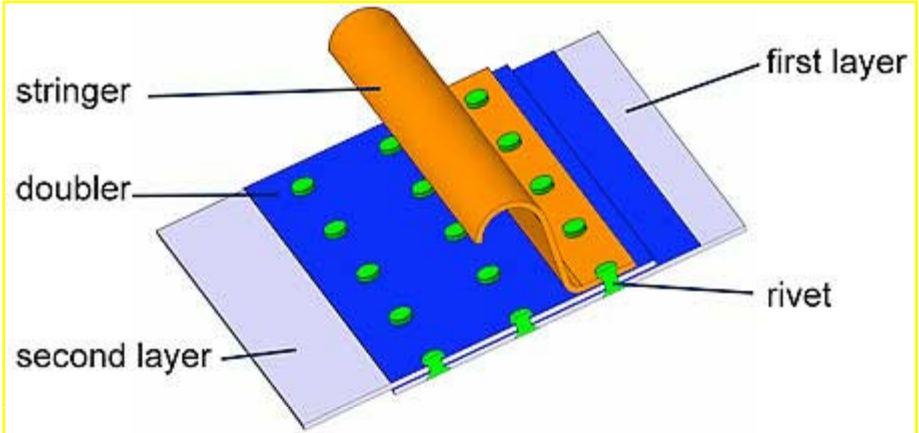

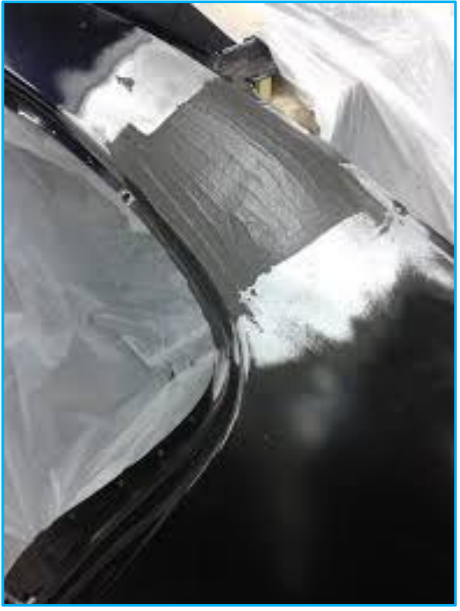



Rivet Tools



Self-piercing rivet

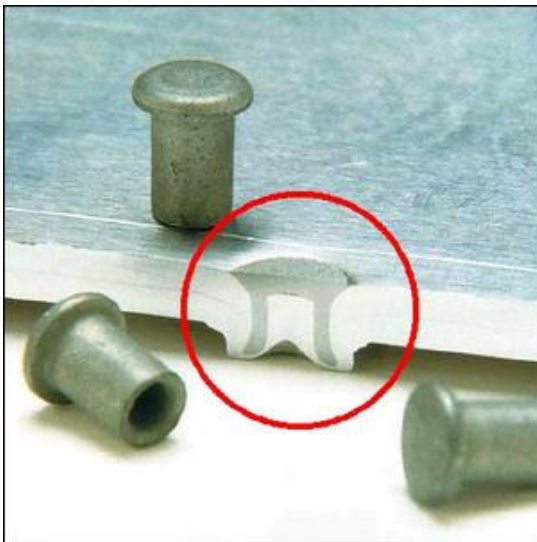
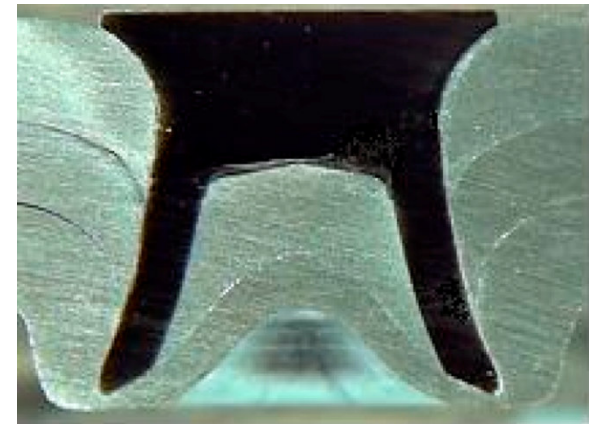
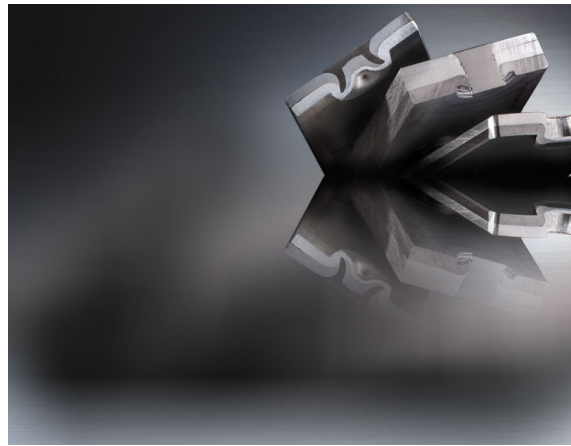
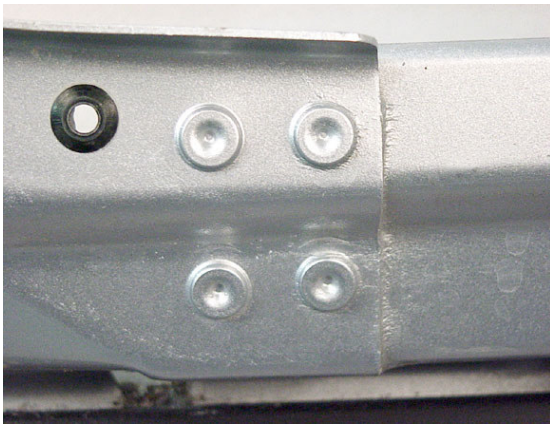

SELF-PIERCING RIVETING

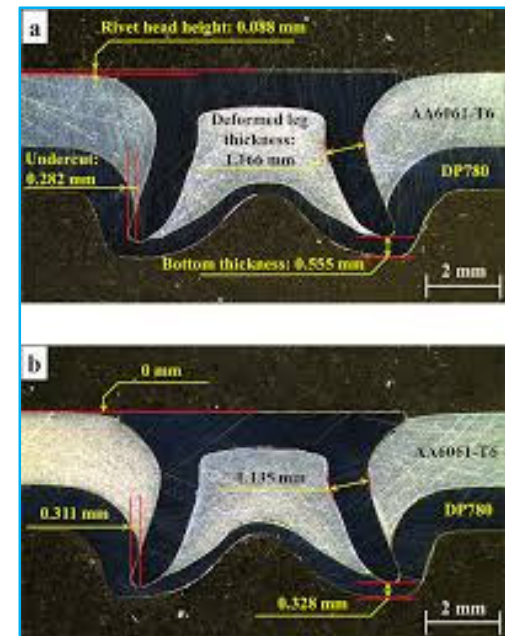
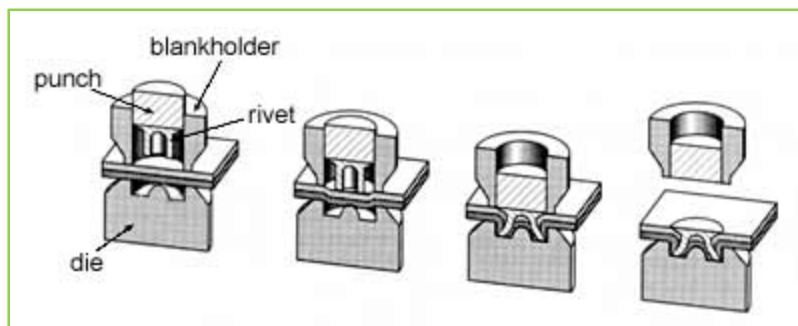
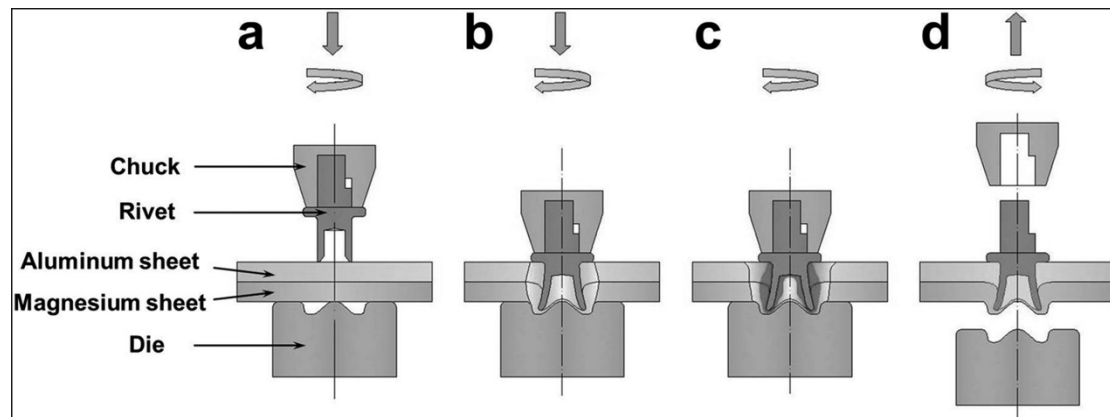
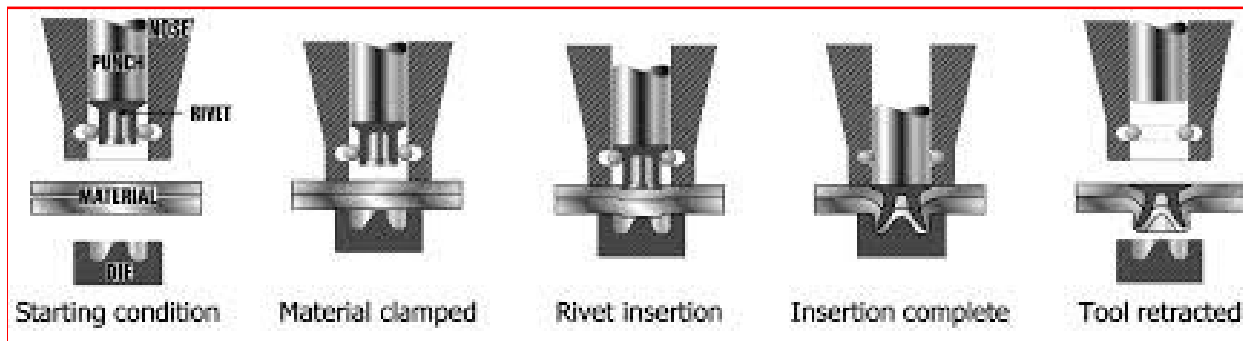

RIVET GUNS



Making Plug Welds in Aluminum

Take your pick in replacing spot welds with plug welds. Either MIG weld in a circle from the inside to the outside or vice-versa. It makes no difference whether you're right- or left-handed either. A simple and practiced slight twist of the wrist can do the job.

