



MADE IN FRANCE
MANUFACTURER SINCE 1964



INVEST IN THE FUTURE



Car Body Welding System

Catalogue Carrosserie • Karosserie-Schweißtechnik Katalog
Catálogo de Soldadura para Carrocería

2016

www.gys.fr

SPOTTER • DENT PULLER • MIG • PLASMA • INDUCTION • LIFT • RIVETING • ACCESSORIES



A family firm since 1964
 Une société familiale depuis 1964
 Familienunternehmen seit 1964

7 Companies / Sociétés / Gesellschaften
500+ Employees / Employés / Mitarbeiter
110 Export markets / Pays distributeurs / Länder

www.gys.fr



3 catalogues
 3 catalogues
 3 Kataloge



Welding & cutting
 Soudure & coupage
 Schweisstechnik



Chargers, boosters & starters
 Chargeurs, démarreurs
 Batterieservicegeräte



Carbody repair
 Réparation carrosserie automobile
 Karrosseriereparatur-Systeme

An international presence
 Une présence mondiale
 Internationale Präsenz

FR Présent dans plus de 100 pays, GYS s'appuie sur son siège social en France et sur ses 5 filiales pour étendre chaque jour son rayonnement sur le monde. Portés par une équipe dynamique et une stratégie de croissance ambitieuse, nous avons pour objectif de consolider la richesse de nos collaborations internationales et conquérir en permanence de nouveaux territoires.

EN Present in over 100 countries, GYS have their head office in France and its five subsidiaries to expand its international influence. Carried by a dynamic team and an ambitious development strategy, we aim to reinforce our international collaborations and constantly conquer new territories.

DE Täglich verlassen über 1000 GYS Geräte, Maschinen und Zubehör das Werk in Laval, um in mehr als 100 Ländern zuverlässig zu funktionieren. Täglich stehen wir mit unseren Handelspartnern in allen Teilen der Welt in engem Kontakt. Mit unseren 5 Niederlassungen sind wir ganz nahe bei unseren Kunden. Und wir arbeiten weiter am Ausbau unserer internationalen Präsenz.



An innovative group
 Un groupe innovant
 Innovative Unternehmensgruppe



Awards

Prestigious partners
 Des partenaires prestigieux
 Renommierter Partner



Certifications

A high tech R&D department

Un centre R&D de pointe • Hochmodernes F&E Zentrum

FR Regroupant plus de 40 experts dans de multiples spécialités (électronique, mécanique, etc.), le département R&D est porteur de l'innovation permanente de produits de haute technicité. En 2014, GYS consacre un investissement important dans l'ouverture d'un nouveau centre d'études pour permettre à nos chercheurs d'élaborer et concevoir des systèmes novateurs à l'aide d'outils de pointe. Les compétences de nos ingénieurs conjuguées à une bonne écoute client permettent de proposer en permanence de nouveaux produits répondant aux besoins de nos utilisateurs.

EN With over 40 expert engineers in multiple specialities (electronic, mechanical, etc.), the R&D department delivers continuous innovation for high tech products. In 2014, GYS established an important investment by opening a new research centre to provide the best resources for our researchers to continue to develop innovative solutions and improvements. By listening to our customers and combining this information with our engineers' expertise, GYS are able to constantly offer new products to meet user demands.

DE Wir beschäftigen in unserer F+E Abteilung mehr als 40 Ingenieure. Die Nähe zu unseren Kunden und das Verständnis für deren Aufgabenstellung bildet die Grundlage für die innovative Weiterentwicklung

unseres Produktportfolios. Im Sommer 2014 bezogen wir das neue GYS F+E Center, das wir mit der neuesten Messtechnik und hochmodernen Laboratorien ausstatteten. Wir analysieren z.B. mit Highspeed-Kameratechnik Schweißverhalten und reproduzieren in einer Klimakammer extreme Wetterverhältnisse und die elektromagnetische Charakteristik unserer Maschinen in einem völlig von äußerer Strahlung abgeschirmten Raum.

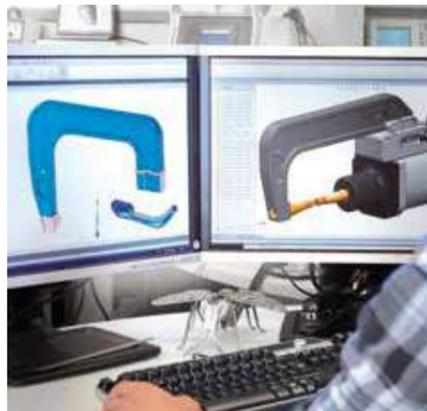

GYS Academy

Académie • Akademie

FR Les centres de formation GYS, situés en France, en Allemagne et en Angleterre sont à votre service pour vous proposer des formations sur nos produits. Nos experts sont à votre écoute et mettent à votre disposition, leurs compétences et leurs connaissances les plus pointues.

EN The GYS training facilities, located in France, Germany and UK are at your service and offer training courses on GYS products. Our product experts are here to listen to your questions and requirements and to share their most advance knowledge.

DE Unsere GYS-Schulungszentren in Frankreich, Deutschland und England, stehen Ihnen für Produktschulungen zur Verfügung. Unsere kompetenten Experten sind für Sie da und unterstützen Sie mit ihren Fachkenntnissen.



100% in-house manufacturing

Une usine 100% intégrée • 100% integrierte Produktion

FR Visiter notre site de production est un parcours surprenant qui traverse une incroyable variété de métiers (électronique, mécanique, transformateur, filerie, tôlerie, peinture...). Notre philosophie repose sur l'intégration complète de notre processus de production pour en maîtriser les moindres détails. Cette industrialisation dans des ateliers certifiés ISO 9001 offre à nos clients une grande flexibilité et une réactivité accrue.

L'investissement et l'amélioration continue de la performance de cet outil de production sont notre raison de vivre, car nous considérons que celle-ci est la garantie de notre compétitivité de demain.

EN Visiting our manufacturing site is a surprising journey which extends through an incredibly wide range of functions (electronic, mechanical, transformer, wiring, sheet metal, painting). Our philosophy is based on the complete integration of our production process to control every detail.

The factory has ISO 9001 certification and is a flexible resource enabling us to be very responsive to customer needs. The investment and continuous improvement in performance of this production facility are the back bone for our existence, we consider it the guarantee for our future competitiveness.

DE Besucher unserer Fertigung sind beeindruckt von der unglaublichen Produktionstiefe. Viele verschiedene Gewerke sind miteinander verbunden: Elektronik, mechanische Fertigung, Trafo-Wickelei, Kabelkonfektionierung, Blechschlosserei und eine zentralgesteuerte Pulverbeschichtungsanlage bis hin zum individuellen Siebdruckverfahren. Unsere Philosophie beruht auf Unabhängigkeit und eigener Qualitätssicherung. Wir wollen jede Phase des Fertigungsprozesses selbst definieren und kontrollieren und sind nach ISO 9001-zertifiziert.

Your global partner

Votre partenaire global • Ihr globaler Partner

Dent pulling	
GYSPT Steel	6
GYSPT Alu/Steel	8
Accessories and consumables	10

Workstations	
Steel	14
Alu/Steel	18

Pulling systems	22
Paintless dent pulling Technologies	24
	28

Spot welding	
GYSPT Traditional	30
GYSPT Inverter	31
Accessories and consumables	38

Riveting system	
GYSPT 8t	40
Accessories and consumables	42

MIG/MAG	
AUTOGYS	44
PEARL	46
NEOPULSE	48

Complete packs	50
Accessories and consumables	52

Helmets	54
Plasma	56
Induction	57
Accessories	60
Protections	68
Battery equipment	69
Complete range 200V-240V	70

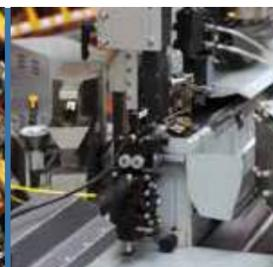
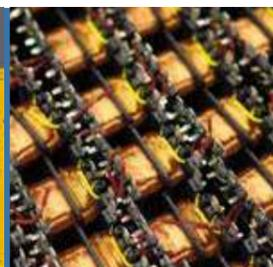

Electronics
- Électronique
- Elektronik

Paintshop
- Peinture
- Lackieranlage

Mechanical engineering
- Mécanique
- CNC-Bearbeitung

Metal work
- Tôlerie
- Blechbearbeitung

Ink printing
- Sérigraphie
- Siebdruck

Transformers
- Transformateurs
- Transformatoren

Cable work
- Filerie
- Kabelkonfektionierung

Assembly
- Montage/tests
- Montage

Logistics
- Logistique
- Logistik



GYSPT ALU PRO FV Alu 110 > 230V
7 500 A

021990

SYNERGIC CONTROL Alu



PATENTS REGISTERED NUMBERS
EUROPEAN TRADEMARK & DESIGN

SYNERGIC CONTROL Acier/Steel/Stahl



NEW
SOFT



Process Alu



Alu Gun Easy



PATENTS REGISTERED NUMBERS
002446450-0001
EUROPEAN TRADEMARK & DESIGN

INCLUDED ALU BOX STANDARD
050020
Details p.12



GYSPT COMBI 230 E.PRO Acier/Steel/Stahl + Alu 230V
3 800 A **7 500 A**

021266

INCLUDED

SPOTTER BOX PRO 050075
+ ALU BOX STANDARD 050020

Details p.12-13



8m

2m
Ø70mm²

3m
Ø50mm²

INCLUDED AUTOMATIC GUN
054035

Acier/Steel/Stahl
Automatic

049802

049482

3 GUNS INCLUDED

PATENTS REGISTERED NUMBERS
00183045-0001
EUROPEAN TRADEMARK & DESIGN

2m
Ø70mm²

INCLUDED MANUAL GUN
052505

Acier/Steel/Stahl
Manual

INCLUDED AUTOMATIC ALU GUN
054066

3m
Ø25mm²

Alu
Automatic

Options (more p.18-19)

Marteaux ALU - Alu hammers 020986	Alu Puller 051003	Inertia hammer 380 g 050051	Lampe à souder - Blow torch - Lotlampe 052741	Novacet+ (Butane/propane/propylene) 380 ml/220 g 040441	Crayon marqueur thermique - Thermal marking pencil 121°C / 250°F 052765	Thermomètre infrarouge - Infrared Thermometer - Infrarot Thermometer -50 / +380°C -58 / +716°F 052994
-----------------------------------	-------------------	-----------------------------	---	---	---	---

MADE IN FRANCE	CE NORM 60974/1	50/60 Hz	I ₂ A	SYNERGIC	T		SEPARATE CABLE GUN	U ₂ V	I _{AM} A	I _{RMS} A	kW	OK	OK	cm	kg
					Acier/Steel	Alu									
GYSPT ALU PRO FV	021990	110>230V	7500	▪	—	AUTOMATIC	—	50 > 200	5	—	0,65	OK	OK	21 x 24 x 36	14
GYSPT COMBI 230 E.PRO	021266	230V	3800 (steel) 7500 (alu)	▪	x2 AUTOMATIC + MANUAL	AUTOMATIC	▪	7,4 (steel) 20 > 200 (alu)	16	2800 (steel)	20	OK	OK	45 x 43 x 29	49,7

MARTEAUX INERTIE - Inertia hammers - Ausziehhammer

1,1 kg
049802

(x20) 052239
(x1) 049482
(x1) 054028 + (x5) 050839

1,1 kg
041813

Clous - Nails - Nägel

Ø 2, M4 (x1) 049277
Ø 2 (x100) 041561

MIG/MAG nozzle for Nail welding 041523

1,7 kg
051201

Rondelles - Washers - Ringe

Ø 16, 8x16 (x1) 049574
(x1) 051218
8x16 (x100) 049444

Griffes - Gripping hook head - Ausbeulkit

049819
2,5 kg

50 cm

COMPLETE KIT
051225

Dent box Bar 050037

(x1) (x 50)
(x1) (x 25)

LEVIER DE DÉBOSELAGE - Levelling lever - Zughebel

PATENTS REGISTERED NUMBERS 001652108-0002 EUROPEAN TRADEMARK & DESIGN

050686

(x2) 052451

55 mm

BARRE DE DÉBOSELAGE DOUBLE ACTION - Levelling bar double action - Zughebelbrücke

053564

0,86 m

Licensed by BETAG.Innovation

Barre de traction - Traction bar - Zugstange

Barre renforcée - Strengthened bar

1,20 m 051171

BARRE DE DÉBOSELAGE - Levelling bar - Zugbrücke

050693

0,85 m

Licensed by BETAG.Innovation

Support double patin - Double pad support - Doppelfüße

050723

Griffes - Gripping hook head - Ausbeulkit

BARRE DE TIRAGE - Lifting bar - Scherenzugbrücke

050716

0,85 m

Barre renforcée - Strengthened bar

PATENTS REGISTERED NUMBERS 001652108-0001 EUROPEAN TRADEMARK & DESIGN

4 049758

6 049734

8 049741

050945

PATENTS REGISTERED NUMBERS 001652108-0003 EUROPEAN TRADEMARK & DESIGN

MANUSPOT
050679

3 m Ø 35 mm²

051690

4 positions - 4 Positionen

MANULINER
050471

EASY TOOL CONNECTION

GYSPT 39.02/04
GYSPT PRO230/400
GYSPT COMBI 230 PRO

EASY GUN
051317

051584

380 g

Anneaux - Rings - Anschweißösen 051652

Fils ondulés - Wavy wires - Wellendraht 051669

Rétreinte - Tempering - Glättwerkzeug 051676

RINGMATIC

052154

included (x 50)

QUICK SPOT AIR GUN

052352

2,5 m

Light weight 920 g

AIR

Graisse contact - Contact grease

050440

OPTION - ADAPTATEUR TEXAS POUR PISTOLET - Adapter for gun

For RINGMATIC & MANUSPOT

052499

For QUICK SPOT AIR GUN

052826

MANUSPOT / MANULINER / QUICK SPOT AIR GUN

Direct impact electrodes (x5) 050839

MANUSPOT/MANULINER

Box of 3 electrodes for accessories 050822



CONSOMMABLES ACIER - Steel consumables - Stahl-Verbrauchsmaterial

STEEL ACCESSORIES & CONSUMABLES



BEST SELLER
DENT BOX BAR
050037



SPOTTER BOX 2600
052277



SPOTTER BOX 2700
053922



SPOTTER BOX STANDARD
053915

x 25		WAVY WIRES x 50 049727	x 25
x 50		STRAIGHT PULLING RINGS x100 050648	x 50
x 1		LIFTING ROD x3 050792	x 1
x 1		ELECTRODE FOR WAVY WIRES x1 049789	x 1
x 1		ELECTRODE FOR RINGS x1 050655	x 1

x 20		STAR WITH COPPER COATING x 20 052239	Dent Box Easy x 10 Spotter Box Pro x 20
x 1		ELECTRODE FOR RINGS ø 16 - 8 x 16 x 1 049574	x 1
x 50		CENTERING RINGS ø 8 x 16 x 100 049444	x 50
x 1		FLAT KEY N°27 x 1 049673	x 1
x 1		EARTH HOOK	x 1
x 1		CARBON HEATING ELECTRODE x 5 049468	x 1
x 1		STAR-CHUCK FOR INERTIA HAMMER x 1 049482	x 1
x 1		HEXAGON KEY	x 1
x 1		ELECTRODE WARMING POINT - ø 16 x 1 049567	x 1

		ELECTRODE FOR AUTO-THREADED RIVETS ø 5 - M5, M6 x 1 049598	x 1
		ELECTRODE FOR RIVETS ø 16,3 x 4,50 x 1 049604	x 1
		THREADED STUDS M5 x 18 x 100 049383	x 50
		THREADED STUDS ø 4 x 16 x 100 049413	x 50
		THREADED STUDS ø 5 x 18 x 100 049420	x 50
		RIVETS - ø 3 x 3,25 x 100 049345	x 100
		RIVETS - ø 3 x 4,50 x 100 049352	x 100

more

	SQUARE LOCK NUT - M8 (x100) 050303		SINGLE HOOK (x1) 051218
	MAGNETIC POSITIONER (x1) 049772		ELECTRODE WHEEL ø16 (x1) 050310
	MAGNETIC EARTH (x1) 049666		EARTH PLATE (x1) 052529
	ELECTRODE FOR MAGNETIC EARTH (x1) 050013		ELECTRODE FOR NAILS Ø 2, M4 (x1) 049277
	THREADED ROD FOR MAGNETIC EARTH (x5) 055438		NAIL Ø 2 (x100) 041561

MASSE PISTOLET ACIER - Steel gun earth adapter - Masse für Stahl Pistole



051997



Ø 25 mm²

DENT BOX EASY
053632

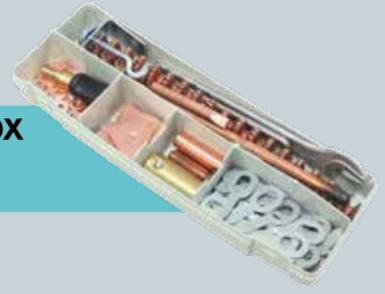

DENT BOX EASY
053632

SPOTTER BOX PRO
050075



BEST SELLER

DENT BOX CONSUMABLES
051515

x 25		WAVY WIRES x 50 049727
x 20		STARS WITH COPPER COATING x 20 052239
x 50		STRAIGHT PULLING RINGS x 100 050648
x 25		TWISTED PULLING RINGS x 50 050631

CONSOMMABLES ALU - Alu consumables - Alu-Verbrauchsmaterial

ALU ACCESSORIES & CONSUMABLES



ALU BOX LIGHT (Ø 4)
051522

x 200		ALU MAGNESIUM SCREWS 12 mm - ø 4 - M4 x 200 050273 x1000 050129
-------	--	---



ALU BOX STANDARD (Ø 4)
050020

x 200		ALU SILICON SCREWS 12 mm - ø 4 - M4 x 200 050280 x1000 050136
-------	--	---

x 5		SCREWABLE RINGS ø 4 x 5 050297
-----	--	---

x 1		LIFTING ROD x 3 050792
-----	--	------------------------------



ALU BOX Ø 5 & 6
048195

	MANDREL FOR ALU GUN	ø 5	048157	x 1
		ø 6	048164	x 1
	ALU MAGNESIUM SCREWS 12 mm	ø 5	048140	x 100
		ø 6	048133	x 100
	ALU SILICON SCREWS 12 mm	ø 5	048126	x 100
		ø 6	048003	x 100
	SCREWABLE RINGS	ø 5	052635	x 5
		ø 6	052628	x 5

more (Ø 4)

	MANDREL FOR ALU GUN - Ø 4 (x2) 049000	x1 050945
	TENSION MANDREL FOR M4 (x1) 050327	x1 050938

MANDRINS POUR PISTOLETS - Mandrels for gun - Pistole mit Anschlussstücke, Zubehör



Pour débousseurs - for dent pullers
D1
048959



Pour soudeuses par point - for spot welding machines
S1 (< nov 2010)
048171

S2 - NEW (> nov 2010)
048188



Écrou - Nut
053199

Microswitch
053267



Acier/Steel/Stahl

EASYLINER

39.02 (230 V) 053618 	2700 (230 V) 055445
------------------------------------	-----------------------------------

GYSPT 39.02 + GYSPT 39.04

Trolley SPOT 1000 053540

Dent box easy 053632 (p.13)

0,86 m

Levelling bar double action 053564 (p.10)

ALL IN 1 BOX

Acier/Steel/Stahl

PROLINER

39.02 (230 V) 035775 	39.04 (400 V) 035782 	PRO 230 (230 V) 035799 	PRO 400 (400 V) 035805
------------------------------------	------------------------------------	--------------------------------------	--------------------------------------

GYSPT 39.02 + GYSPT 39.04 + GYSPT PRO 230 + GYSPT PRO 400

Trolley SPOT 800 051331

Cable support 052284

0,86 m

Levelling bar double action 053564 (p.10)

Dent box bar 050037 (p.12)



Spot 600
053533



Spot 800
051331



Spot 1000
053540



Spot 1600
051348



Workstation
050747



OPTIONS

- Manuliner 050471
- Ringmatic 052154
- QUICK SPOT AIR GUN 052352



MADE IN FRANCE

Acier/Steel/Stahl

SPEEDLINER

39.02 (230 V)
035010

39.04 (400 V)
035027

SPEEDLINER

PRO 230 (230 V)
036017

PRO 400 (400 V)
036024



OPTION
Housse de protection
- Protection cover
- Schutzhaube
048881



GYSPOT 39.02



GYSPOT 39.04



GYSPOT PRO 230



GYSPOT PRO 400



Trolley SPOT 1600 051348



Manuspot 050679 (p.11)



Leveling bar 050693 (p.10)



Leveling lever 050686 (p.10)



4 gripping multihook head 049758 (p.10)



6 gripping multihook head 049734 (p.8)



3 lifting rods 050792 (p.112)



Dent box consumables 051515 (p.13)



Magnetic earth 049666 (p.12)

SPEEDLINER
(without generator)
035058



Workstation 050747



Fixing kit 051362



Manuspot 050679 (p.11)



Leveling bar 050693 (p.10)



Lifting bar 050716 (p.10)



Double pads support 050723 (p.10)



Leveling lever 050686 (p.10)



Strengthened bar 1,2m 051171 (p.10)



4 gripping multihook head 049758 (p.10)



6 gripping multihook head 049734 (p.8)



8 gripping multihook head 049741 (p.10)



3 lifting rods 050792 (p.112)



Dent box consumables 051515 (p.13)



Magnetic earth 049666 (p.12)

GYSLINER
(without generator)
035133



MADE IN FRANCE



Acier/Steel/Stahl

GYSLINER

39.02 (230 V)
035096

39.04 (400 V)
035102

GYSLINER

PRO 230 (230 V)
036031

PRO 400 (400 V)
036048



GYSPOT 39.02



GYSPOT 39.04



GYSPOT PRO 230



GYSPOT PRO 400

MARTEAUX ALU
- Alu hammers

020986



ALU

ALU PULLER
051003



050921

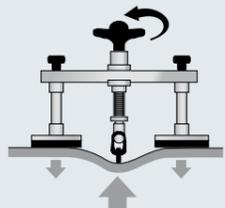

4 positions

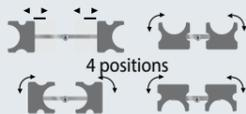

050945



050938

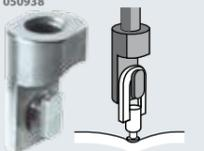

Housse de protection
- Protection cover
- Schutzhaube
048881



MARTEAU À INERTIE
- Inertia hammer
- Ausziehhammer



380 g
050051

LAMPE À SOUDER - Blow torch - Lötlampe

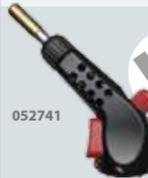

052741



HIGH QUALITY

Novacet +
(Butane/propane/
propylene)
380 ml/220 g
040441



BROSSES - Brushes
- Bürsten - Brosses
- Cepillos



Inox - Stainless - Edelstahl
044258

CRAYON MARQUEUR THERMIQUE
- Thermal marking pencil



052765

121°C / 250°F

THERMOMÈTRE INFRAROUGE
- Infrared Thermometer
- Infrarot Thermometer



052994

-50 / +380°C
-58 / +716°F

SPRAY REFROIDISSEUR
- Freezer spray



-50°C
400 ml
(x 12)
048898

GEL BARRIÈRE THERMIQUE
- Heat barrier spray



054325



Alu
PROLINER ALU PRO FV

035836



MADE IN FRANCE



GYSPT ALU PRO FV



Trolley SPOT 800 051331



Alu puller 051003



Cable support 052284



GYSPT ALU PRO FV



Trolley SPOT 1600 051348



Alu puller 051003

Fixing kit 051362

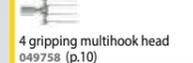

4 gripping multihook head 049758 (p.10)



Levelling bar 050693 (p.10)



Alu Box Ø 5 & 6 048195 (p.13)



Alu hammers 020986

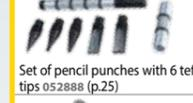

Set of pencil punches with 6 teflon tips 052888 (p.25)



Mini disc sander 051829 (p.64)



051423 (p.62)



Infrared Thermometer 052994



Thermal marking pencil 052765

Alu

SPEEDLINER ALU PRO FV

036055



MADE IN FRANCE



Acier/Steel/Stahl **+** Alu

SPEEDLINER COMBI 230 E.PRO

036062

Complete solution

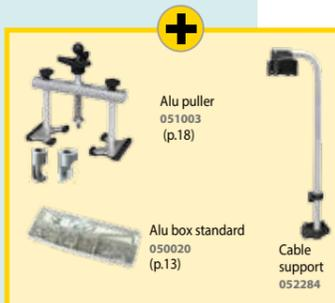
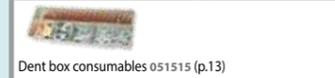

Cable support 052284

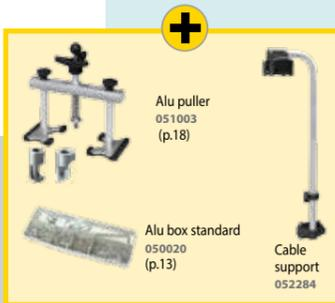
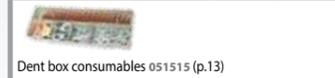
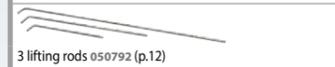
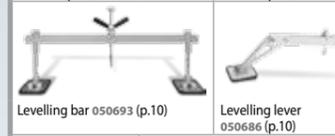
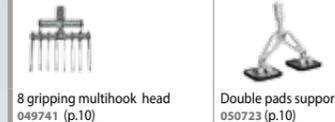
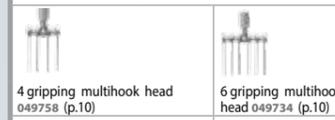

Cable support 052284



Expert solution

Acier/Steel/Stahl **+** Alu

GYSLINER COMBI 230 E.PRO

036079

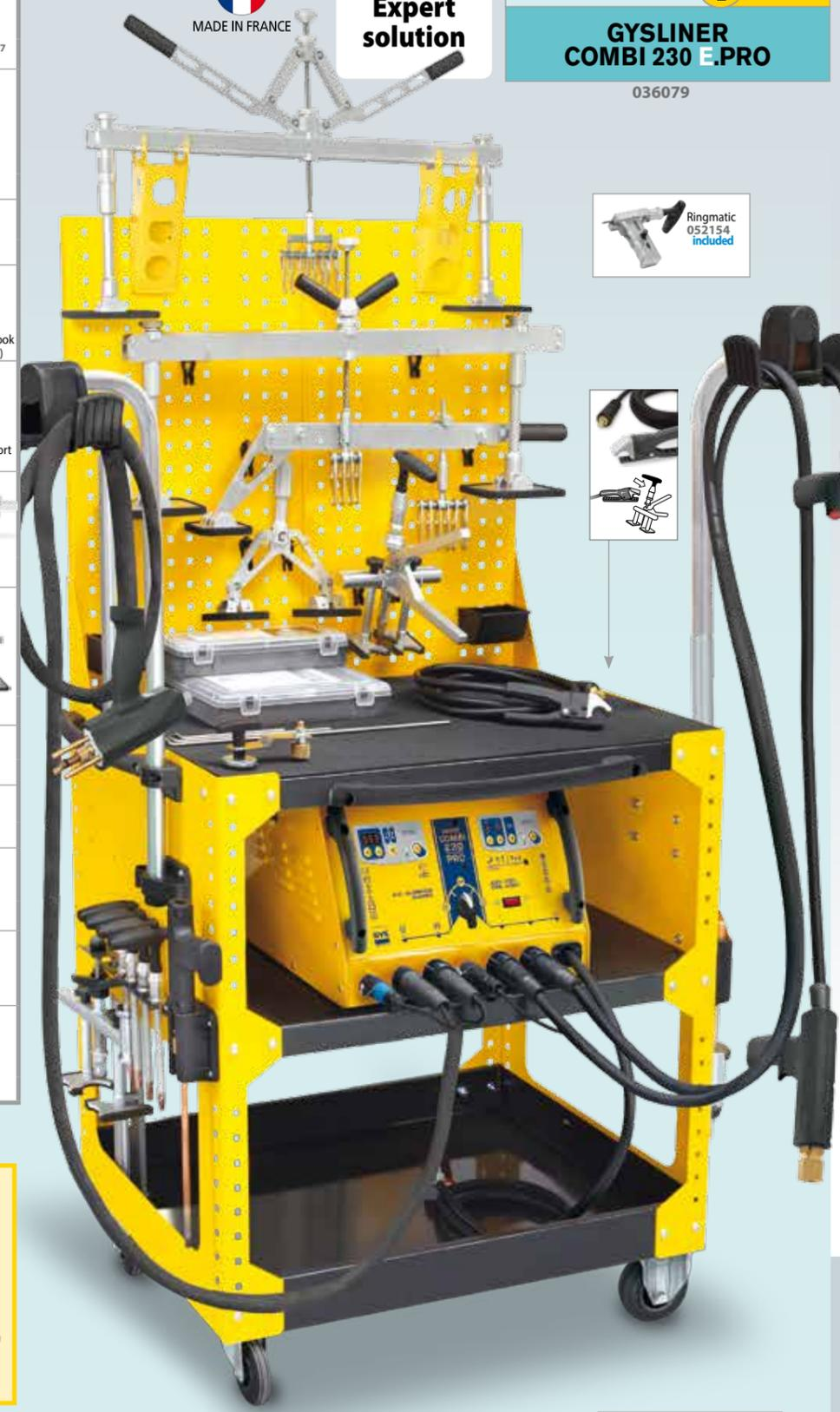

ÉQUERRE DE TIRAGE - DRAW ALIGNER
- SCHNELLAUSBEUL-RICHTAUSLEGER

052475

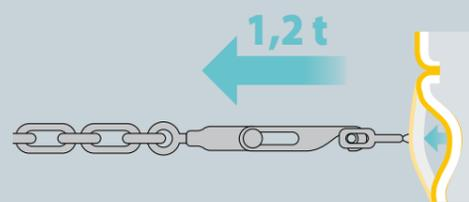

NEW DESIGN

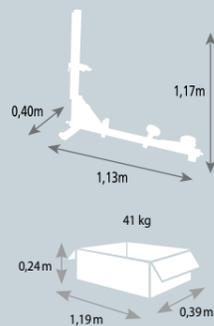

OPTION
Bras de bas de caisse
- Rocker panel arms
for draw aligner
- Abstütztraverse
für Richtausleger

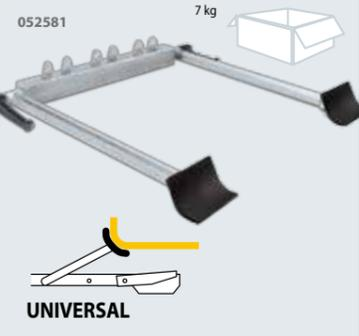

SYSTÈME DE TIRAGE SMART PULLER SILVER - SMART PULLER SILVER PULLING SYSTEM - SCHNELLAUSBEUL-RICHTAUSLEGER SMART PULLER SILVER

054820

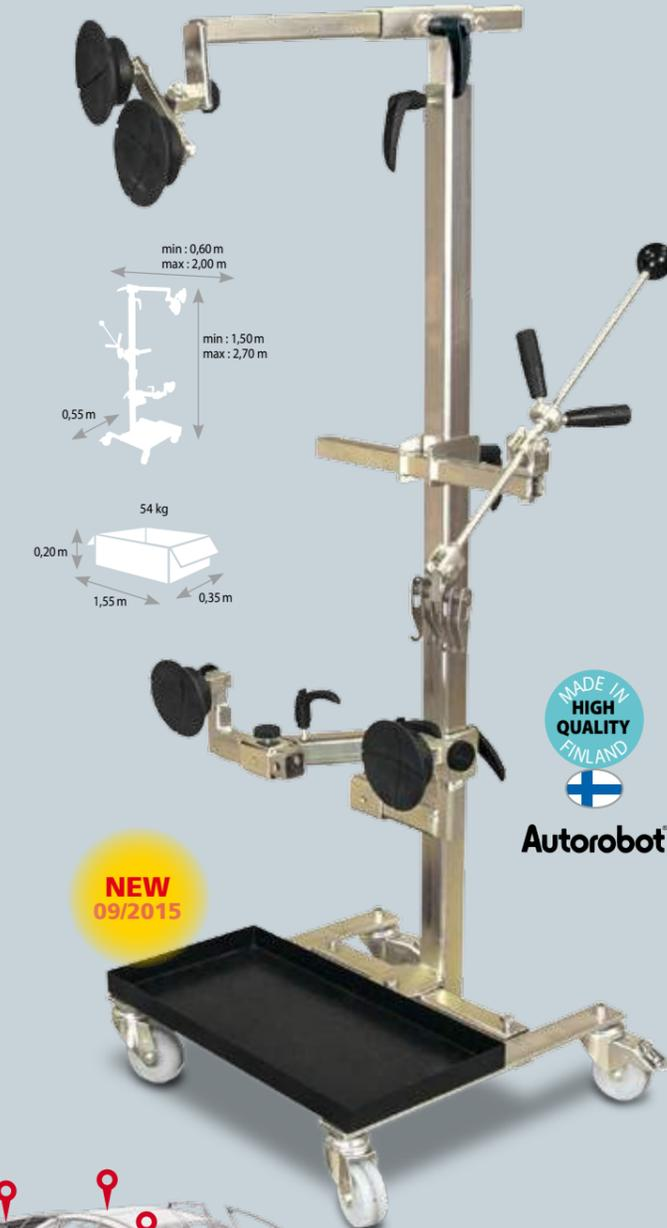

Autorobot

NEW
09/2015



- Portières - Doors - Türen
- Montants - Supports - Scheibenrahmen
- Capot - Hood/Bonnet - Haube
- Armature - Armature - Rahmen
- Bas de caisse - Rocker panel - Schweller
- Ailes - Wings - Kotflügel
- Toit - Roof - Dach
- Hayon - Hatchback - Heckdeckel



INCLUDED Accessories

INDUCTEUR DÉBOSSÉLAGE - Dent Pulling Inductor - Ausbeul Induktor



Débosselage rapide et sans peinture
- Fast paintless dent pulling
- Lackschadenfreies Ausbeulen



GYS DUCTION AUTO DENT REPAIR
054981



Dent pulling Inductor
Débosselage - Dent pulling -
Ausbeul Induktor

OPTION

Spray refroidisseur
- Freezer spray

-50 °C
400 ml

(x 12)
048898



GYS DUCTION AUTO (Steel / Acier)

	50 Hz	A	W	kHz	PFC	FV	Liquid Cooling	Cable L (m)	Inductor	cm	kg
110V, 1~ 230V, 1~	25 16	2400	35+120	■	■	—	2	2,5	22 x 36 x 27	7,2	

KIT MAGNÉTIQUE DE DÉBOSSÉLAGE SANS PEINTURE - Paintless Dent Repair magnetic kit - Magnetisches Ausbeul-Kit

053168

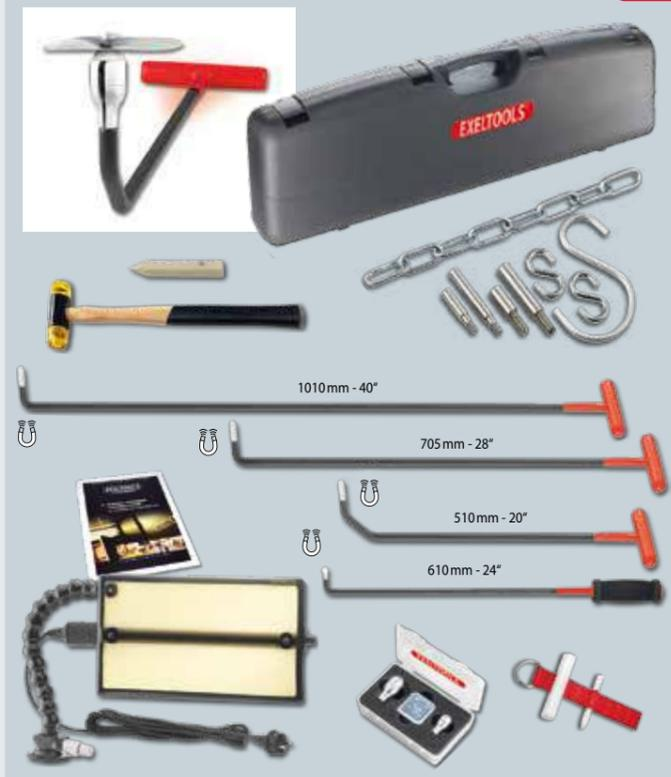

EXELTOOLS

LAMPE DE DÉBOSSÉLAGE - Paintless Dent Repair lamp - Ausbeullampe

ULTRA LIGHT CARBON X40 PW 053175



GLUE PULLER (Acier/Alu + Steel/Alu)



KIT DE 6 COINS DE FRAPPE - Set of 6 pencil punches - Beulenstemmer-Satz mit 6 Tefloneinsätzen



BARRETTES ANNEAUX PLASTIQUE - Plastic Multipads - Üsen-Klebe pads

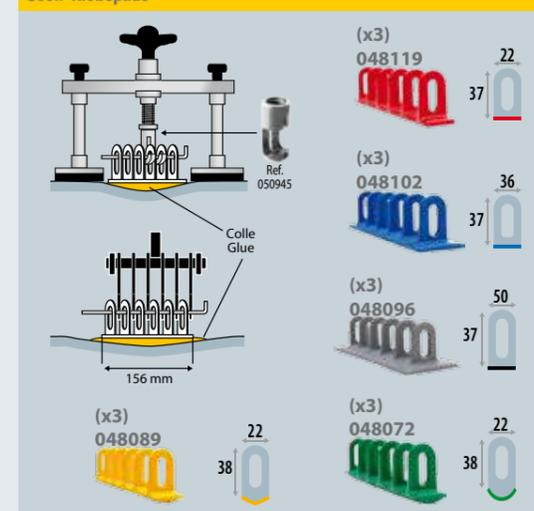

KIT DÉBOSSÉLAGE SANS PEINTURE (paintless) - Dent Pulling Kit (paintless) - Dellenausbeulhebel-Set



MARTEAU INERTIE PNEUMATIQUE - Pneumatic inertia hammer - Unterdruck-Schlaghammer



KIT COUSSINS GONFLABLES - Air Cushion Kit - Luftpolster-Spreizkissen-Satz



MARTEAU À INERTIE À VENTOUSES (POMPAGE MANUEL) - PUMP AIR SUCTION SLIDE HAMMER - Man. Unterdruck-Schlaghammer





SPOT LIFT

052864

Haute stabilité
- High stability

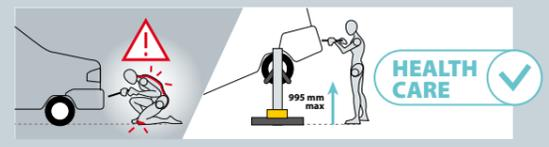
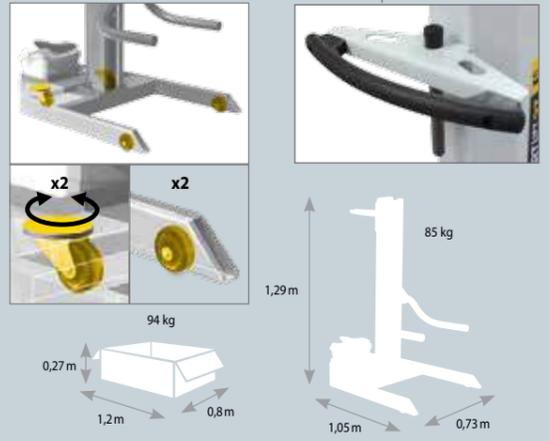

OPTION
Outil de levage pour bas de caisse
- Rocker panel lifting tool
- Auflage für Seitenschweller



SPOT LIFT PRO

053557

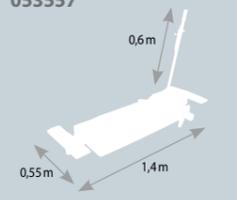

60 cm max
14 cm min



OPTION
Réhausseur pour 4x4 et utilitaires
- Height adjuster for 4x4 & utility vehicles
- Erhöhung f. 4x4 und Leicht-LKW



CHARIOT DE MANUTENTION PRISE SOUS ROUE

- Wheel truck - Kiz-Montagelift, fahrbar

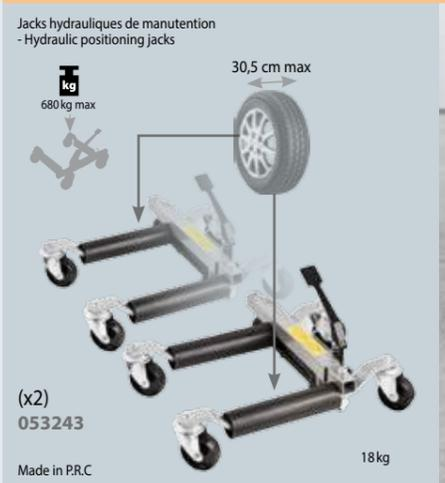

TABOURETS DE MANUTENTION

- Wheel dollies - Radhacker

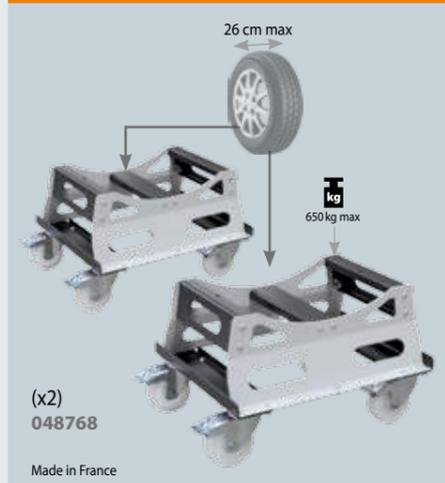

ÉVOLUTION TECHNOLOGIQUE

TECHNICAL IMPROVEMENTS - TECHNISCHE ENTWICKLUNG - MEJORAS TECNICAS

- | | | | |
|--|---|--|--|
| <p>France</p> <p>Facteurs d'évolution :</p> <ul style="list-style-type: none"> • Challenge CO2 = faible poids • Crash test = ★★★★★ • Anti corrosion = nouveaux revêtements • Esthétique et visibilité plus sophistiquées. | <p>UK</p> <p>Evolution factors :</p> <ul style="list-style-type: none"> • CO2 Challenge = low weight • Crash test = ★★★★★ • Anti-corrosion = new coatings • Improved aesthetics and demand for better occupant visibility. | <p>Germany</p> <p>Entwicklungsfaktoren :</p> <ul style="list-style-type: none"> • CO2 Challenge = geringes Gewicht • Crash-Test = ★★★★★ • Anti-Korrosion = neue Beschichtung • Modernes Technik-Design. | <p>Spain</p> <p>Factores de evolución :</p> <ul style="list-style-type: none"> • Challenge CO2 = peso débil • Ensayo de choque = ★★★★★ • Anti-corrosión = nuevos revestimientos • Diseño y visibilidad mas sofisticadas |
|--|---|--|--|

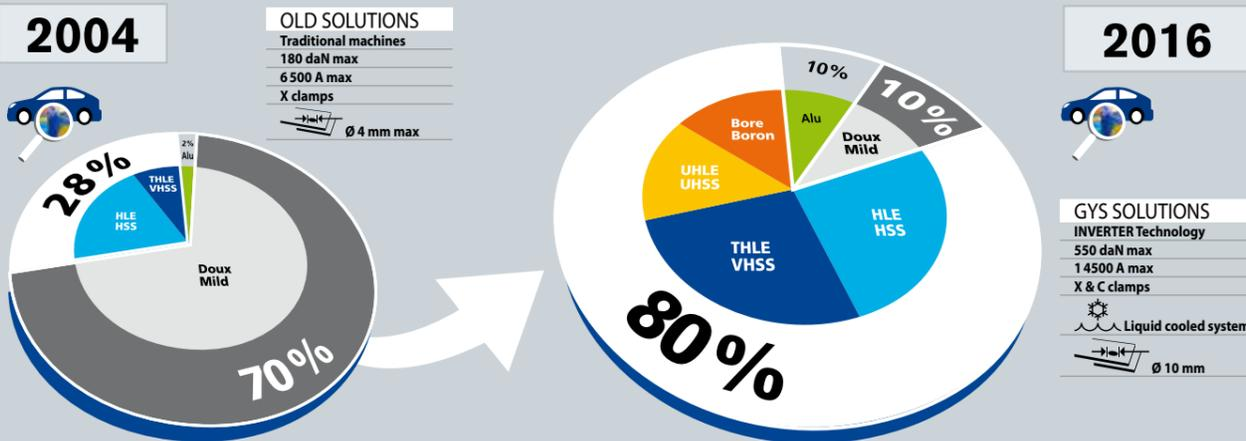

Exemple de carrosserie nouvelle génération
- An example of new generation car body
- Beispiel einer Karosserie der neuen Generation
- Ejemplo de la nueva generacion de carrocerias

HOMOLOGATIONS PRODUITS

MANUFACTURER APPROVALS / COMPLIANCE - PRODUKT HOMOLOGATIONEN - PRODUCTOS HOMOLOGADOS

	Audi	Bentley	BMW	Jeep	Mercedes	smart	Dacia	Dodge	EvoBus	Volvo	Land Rover	Jaguar	Tata
DENT PULLER													
GYSPT 2600													
GYSPT 39.02/04, PRO230/400													
PROLINER/SPEEDLINER/GYSLINER													
GYSPT ALU FV													
RESISTANCE SPOT WELDERS													
GYSPT 32D													
GYSPT INVERTER 100R													
GYSPT INVERTER BP-LX													
GYSPT INVERTER BP-LC-s7													
GYSPT INVERTER BP-LCX-s7													
GYSPT INVERTER BP-LQC-s7													
GYSPT EVOLUTION PTI-s7													
VAS 821 101 - Spot Welder													
MIG / MAG													
T1 GYS AUTO													
T3 GYS AUTO													
NEOPULSE 270-T2 / 300													
PLASMA													
CUTTER 21/21KF													
CUTTER 31FV													
INDUCTIVITY													
GYSDUCTION AUTO													



RANGE



	32 D	100 R	BP-s7	EVOLUTION PTI-s7
Doux - Mild	< 2,0 mm	•	•	•
	> 2,0 mm	•	•	•
HLE/THLE - HSS/VHSS	< 2,0 mm	•	•	•
	> 2,0 mm	< 2,5 mm	•	•
UHLE/BORE - UHSS/BORON	< 2,0 mm	Difficult	•	•
	> 2,0 mm	Difficult	•	•

Nombre de points (non stop : 10 points/min)	0,8 + 0,8 mm	25	30	2000	2000
- Number of spots (non stop : 10 spots/min)	2,5 + 2,5 mm	7	10	120	120

Inverter Technology	—	•	•	•
EMF Directive 2013/35/UE	—	—	BODY PROTECT TECHNOLOGY	•
Système de refroidissement - Cooling system	AIR	AIR	LIQUID	LIQUID
Régulation automatique - Automated regulation	I (A)	—	•	•
	daN	—	•	•
	Ø	irregular	constant	constant
SPOT 7 TECHNOLOGY	—	—	• (LC, LQC, LCX)	•

Pince - Clamp	X	• (32DX)	• (100R-X)	• (BP.LX)	—
	C	• (32DC)	• (100R-C)	• (BP.LC)	•
	X+C	—	• (100R-CX)	• (BP.LCX)	—
Transformer Inside Clamp	—	—	—	—	•
Cables (L)	—	2,5 m	2,5 m	2,5 m	4 or 6 m
Includes gun	—	•	•	•	option
Fuse	—	32 A	32 A	32 A	25 A (14 500 A) 16A (11500 A)

BP BODYPROTECT TECHNOLOGY 2013/35/UE

UNIQUE ELECTRO-MAGNETIC FIELD PROTECTION by GYS

®BODY PROTECT is a proprietary GYS technology that minimises electromagnetic fields created by the machine.

Compliant : Directive 2013/35/UE
Certified by : Laboratory EMITECH

MADE IN FRANCE

LA SOLUTION GLOBALE - THE GLOBAL SOLUTION

Other technologies	GYS BODYPROTECT TECHNOLOGY
B1: 10 < 25 cm (Norm : 3 cm max)	B1: 0 cm (Norm : 3 cm max)
B2: 25 < 35 cm (Norm : 30 cm max)	B2: 5 cm (Norm : 30 cm max) / 4 cm (Norm : 30 cm max)
B3: 35 cm (Norm : 20 cm max)	B3: 0 cm (Norm : 20 cm max)
B4: 35 cm (Norm : 20 cm max)	B4: 0 cm (Norm : 20 cm max)

TRADITIONAL • AIR COOLED • 7 500 A

INVERTER • AIR COOLED • 10 000 A

PORTASPOT 230

6 300 A - 120 daN

230V

022256

NEW



MADE IN FRANCE



DELIVERED WITH PX 1



ARMS

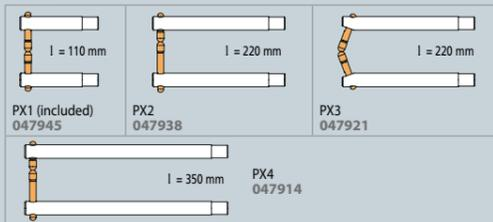

ELECTRODES



CAPS & ACCESSORIES



50/60 Hz	A	A	A	mm	V	← m	∅ mm ²	100% CU	(no arm) cm	kg
1 x 230V	16(D)	6 300	8 900	2+2	2,45	2,5	3x2,5 H05VVE	OK	36x29 x10	10

GYSPOT 32D-X

7 500 A

2x400V

019881

GYSPOT 32D-C

7 500 A

2 x 400V

019898



OPTION 32D-X & 100R-X

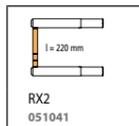

INCLUDED 32D-X & 100R-X

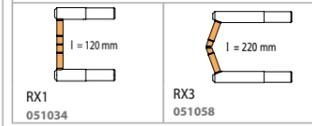

INCLUDED 100R-X

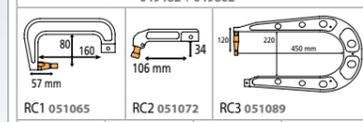

INCLUDED 32D-C & 100R-C

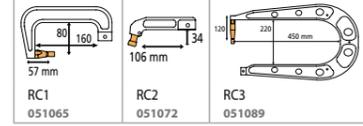

OPTION 32D-C, 100R-C, 100R-CX



GYSPOT INVERTER 100R-X

10 000 A

3x400V

019911



GYSPOT INVERTER 100R-C

10 000 A

3 x 400V

019928



GYSPOT INVERTER 100R-CX

10 000 A

3 x 400V

022317



NEW

GYSPOT TRACEABILITY SOFTWARE included
SAVE spot welding configuration and EXPORT data

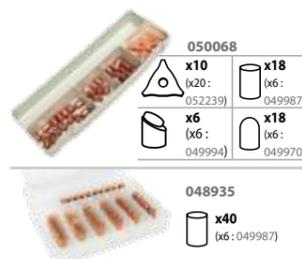

OPTION X & C ARMS p.38

MADE IN FRANCE	CE NORM.	60974/1	50/60 Hz	A	A	A	mm	Uo	Cables		100% CU	cm	kg	
									Air Cooled	← m				∅ mm ²
GYSPOT 32D.X	019881		50/60 Hz	A	A	A	3+3	1,2+3	11	2,2	200	OK	55 x 75 x 190	100
GYSPOT 32D.C	019898		2 x 400V	32 (D)	7 500	10 500	3+3	1,2+3	11	2,5	150	OK	55 x 75 x 190	100
GYSPOT 100R.X	019911		50/60 Hz	A	A	A	3+3+3	1,5+3	16	8	3 x 6 H07RNF	OK	70 x 99 x 208	108
GYSPOT 100R.C	019928		3 x 400V	32 (D)	10 000	—	3+3+3	1,5+3	16	2,5	150	OK	70 x 99 x 208	107
GYSPOT 100R.CX	022317		50/60 Hz	A	A	A	3+3+3	1,5+3	16	8	4 x 6 H07RNF	OK	70 x 99 x 208	125



GYS POT INVERTER BP-LX For mild steel, HSS, UHSS Boron steel

13 000 A 550 daN
Liquid cooled

6,5 kg (included X1) Cable 2,5 m Ø200 mm² Double pressure Ø 10 mm

3 x 400V
019652

BP BODYPROTECT TECHNOLOGY 2013/35/UE
UNIQUE ELECTRO-MAGNETIC FIELD PROTECTION by GYS

GYS POT TRACEABILITY SOFTWARE included
SAVE spot welding configuration and EXPORT data



INCLUDED

	Monopoint/Spot welding (x1) 049291
	SPOTTER BOX PRO (p.13) 050075
	Inertia hammer 049482 + 049802
	X1 8 bar / 550 daN (X arms Ø 25 mm) 050501

050068

	x10 (x20: 052239)
	x18 (x6: 049987)
	x6 (x6: 049994)
	x18 (x6: 049970)

048935

	x40 (x6: 049987)
--	------------------



CORAGARD CS 330 10l
Liquide de refroidissement
Cooling liquid
Kühlmittel
Enfriamento líquido
Refrigeración líquida
052246

Housse de protection
- Protection cover
- Schutzhaube
050853



LIQUID COOLED INVERTER



Included Support haute stabilité
-High stability support
Compatible gyro
+ 054196

GYS POT INVERTER BP-LC-s7 For mild steel, HSS, UHSS Boron steel

13 000 A 550 daN
Liquid cooled

6,5 kg (included C1) Cable 2,5 m Ø200 mm² Double pressure Ø 10 mm

3 x 220V
020931

3 x 400V
020757

BP BODYPROTECT TECHNOLOGY 2013/35/UE
UNIQUE ELECTRO-MAGNETIC FIELD PROTECTION by GYS

EDC ENERGY DYNAMIC CONTROL Automatic C clamp
AUTOMATIC MODE

GYS POT TRACEABILITY SOFTWARE included
SAVE spot welding configuration and EXPORT data

INCLUDED

	Monopoint/Spot welding (x1) 049291
	SPOTTER BOX PRO (p.13) 050075
	Inertia hammer 049482 + 049802
	C1 8 bar / 550 daN 019140
	Arm panel

OPTION

10-14 kg
GYRO 360° for BP-LC
051737

MADE IN FRANCE 60974/1	50/60 Hz	A	RMS	U _o	mm	Cables			100% CU	cm	kg	
						Liquid / Air Cooled	m	Ø mm ²				
GYS POT BP.LX	3 x 400V	32 (D)	13 000	16	3 + 3 + 3	1,5 + 3	Liquid	2,5	200	OK	65 x 80 x 205	160
GYS POT BP.LC-s7	200 208 230 240	63 (D)	10 500 11 000 12 000 12 500	15 15,5 17 18	3 + 3 + 3	1,5 + 3	Air	2,5	150			
GYS POT BP.LC-s7 220V	020931	3 x	—	—	—	—	—	8	4 x 6 H07RNF (BP220V:4x16)	—	—	—



GYSPT INVERTER BP-LQC-s7 For mild steel, HSS, UHSS Boron steel

13 000 A
550 daN
Liquid cooled

6,5 kg (including QC1) Cable 2,5 m Ø 200 mm² Ø 10 mm

3 x 400V
021082



Included Support haute stabilité - High stability support Compatible gyro

054196

INCLUDED

	Monopoint/ Spot welding (x1) 049291
	SPOTTER BOX PRO 050075 p.13
	Inertia hammer 049482 + 049802
	QC1 021167 8 bar / 550 daN
	Arm panel



LIQUID COOLED INVERTER

MADE IN FRANCE

for : BP LQC **NEW GENERATION**

550 daN **6,5 kg** including C1

LIQUID COOLED REFROIDISSEMENT LIQUIDE Ø 10 mm

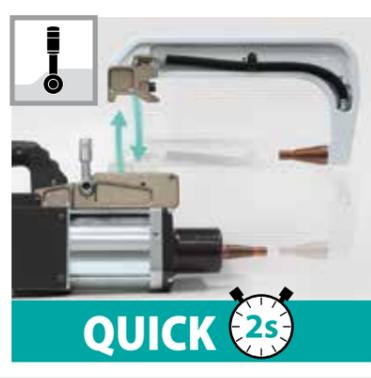
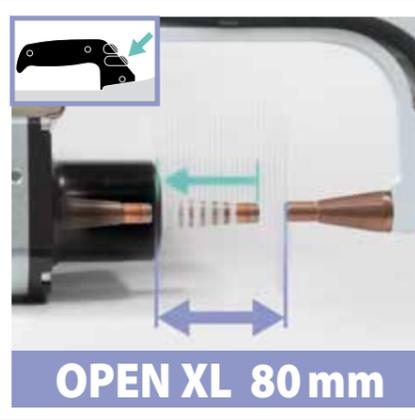

C Arms - Caps Ø13 mm
Bras isolés - Isolated arms - Isolierte Bügel

= Aluminium nickelé - Nickel plated aluminium - Aluminium (vernickelt)

	QC1 8 bar/550 daN 021167		QC4 8 bar/550 daN 021228		QC6 8 bar/550 daN 021259		QC5 4 bar/150 daN 021235
	QC3 8 bar/550 daN 021204		QC2 8 bar/550 daN 021181		QC7 8 bar/550 daN 022072		

Arm panel 022065

MADE IN FRANCE 60974/1	50/60 Hz	A	RMS A	mm	U _o V	Cables			100% CU	cm	kg	
						Liquid / Air Cooled	m	Ø mm ²				
GYSPT BP.LQC-s7 021082	3 x 400V	32 (D)	13000	3 + 3 + 3	1,5 + 3	16		2,5	200	OK	65 x 80 x 205	160
								2,5	150			
								8	4 x 6 H07RNF			

INVERTER • LIQUID COOLED • QC CLAMP • 13 000 A

INVERTER • LIQUID COOLED • QC CLAMP • 13 000 A



GYSPT SPOT INVERTER BP-LCX-s7 For mild steel, HSS, UHSS Boron steel

13 000 A
550 daN
Liquid cooled

6,5 kg (included X1 or C1) Cable 2,5 m Ø200 mm² Double pressure Ø 10 mm

3 x 220V 020948 **3 x 400V** 020764



INCLUDED	
	Monopoint/ Spot welding (x1) 049291
	SPOTTER BOX PRO (p.13) 050075
	Inertia hammer 049482 + 049802
	C1 8 bar / 550 daN 019140
	X1 8 bar / 550 daN (X arms Ø 25 mm) 050501
	Arm panel

Included Support haute stabilité -High stability support Compatible gyro + 054196



NOUVELLE GAMME • NEW RANGE • NEUE PRODUKTREIHE
7 500 10 000 A 13 000 A 14 500 A

LIQUID COOLED INVERTER



Very light
10,5 kg

GYSPT SPOT INVERTER EVOLUTION PTI-s7 For mild steel, HSS, UHSS Boron steel

14 500 A
550 daN
Liquid cooled

TRANSFORMER INSIDE
FUSE 16 > 25 A Cable 4 m or 6 m Double pressure Ø 10 mm

3 x 220V 4M 022188 6M 022195 **3 x 400V** 4M 020894 6M 020900

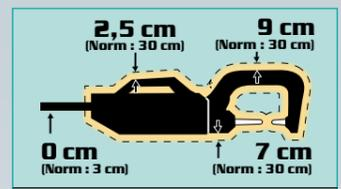

Compliant : Directive 2004-40-CE Certified by : Laborarory EMITECH



INCLUDED	
	C1 isolé - insulated 8 bar / 550 daN 021402
	Arm panel



MADE IN FRANCE 60974/1	Cables	100% CU	cm	kg	Uo	I _{RMS}	A	50/60 Hz	mm		Cables		100% CU	cm	kg
									3+3+3	1,5+3	2,5 m, Ø 200 mm ² , Liquid	2,5 m, Ø 150 mm ² , AIR			
GYSPT BP.LCX-s7	020764	3 x 400V	32 (D)	13 000	16										
GYSPT BP.LCX-s7 220V	020948	3 x 200-208-220-240	63 (D)	10 500 11 000 12 000 12 500	15 15,5 17 18	3+3+3	1,5+3	2,5 m, Ø 200 mm ² , Liquid	2,5 m, Ø 150 mm ² , AIR	8 m, 4x6 H07RN-F (BP 220V-4x6)	OK	65 x 80 x 205	180		
GYSPT EVOLUTION PTI-s7	4M 020894 6M 020900	3 x 400V	25 (D) 16 (D)	14 500 11 500	8										
GYSPT EVOLUTION PTI-s7 220 V	4M 022188 6M 022195	3 x 200-208-220-240	40 (D) 14500A 32 (D) 11500A	12 500 13 000 14 500 14 500	6,95 7,2 8 8,3	3+3+3	1,5+3	4 m, Liquid	6 m, Liquid	OPTION 051010 : 1,5 m, Ø 200 mm ²	8 m, 4x4 H07RN-F 8 m, 4xAWG8 (SOOW)	OK	65 x 80 x 230	100	

INVERTER • LIQUID COOLED • X & C CLAMP • 13000 A

INVERTER • LIQUID COOLED • TRANSFORMER C CLAMP • 14500 A

for : 32DX • 100RX • 100RCX • BPLX • BPLCX

for : EVOLUTION PTI • BPLCX • BPLC

550 daN**6,5 kg** including X1

- DOUBLE PRESSURE
- LIQUID COOLED
REFROIDISSEMENT LIQUIDE
- Ø 10 mm



MADE IN FRANCE

X ARMS
Ø 25 mm

Remote control (BP)

Digital screen control
Change Mode & Parameters

Clamp control

**550 daN****6,5 kg** including C1

- DOUBLE PRESSURE
- LIQUID COOLED
REFROIDISSEMENT LIQUIDE
- Ø 10 mm



MADE IN FRANCE

**550 daN**

Transformer inside

- DOUBLE PRESSURE
- AIR COOLED + LIQUID COOLED
DOUBLE REFRIGERATION
AIR + LIQUID
- Ø 10 mm

X Arms - Caps Ø13 mm

C Arms - Caps Ø13 mm

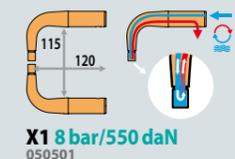
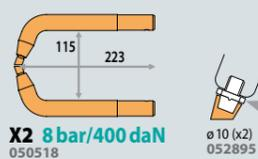
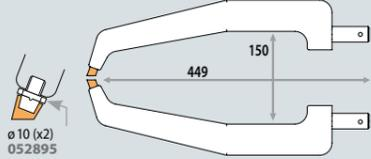
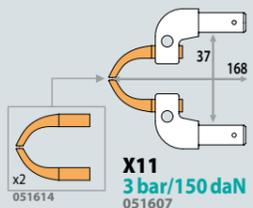
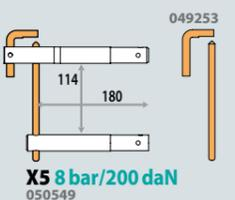
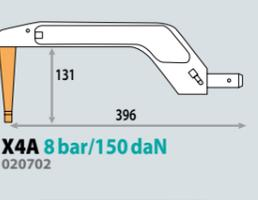
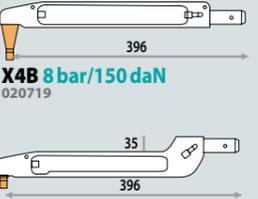
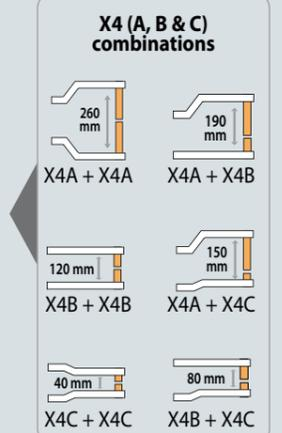
X1 8 bar/550 daN
050501X2 8 bar/400 daN
050518X4 8 bar/120 daN
050532X11
3 bar/150 daN
051607X5 8 bar/200 daN
050549X4A 8 bar/150 daN
020702X4B 8 bar/150 daN
020719X4C 8 bar/150 daN
020726

Arm panel

X4A (x2) + X5 + X2
022324X4A (x2) + X4B + X4C + X2
020733

Consommables X & C • X & C Consumables

- Type A C-clamp or X-clamp Ø 13 mm (x6) 049987
- Type B C-clamp or X-clamp Ø 13 mm / Ø 5 mm (x6) 055506
- X2, X4, C11 arms Ø 13 mm (x6) 049994
- TYPE F For single sided gun Ø 13 mm (x6) 049970

Europax anti-corrosion
052758 500mlGrais contact
Contact grease
050440Caps remover
050846Lame - Blade
052857Affuteur de caps - Cap grinder
048966Boite consommables Spotter
• Welding Spotter consumables
• Zubehör für Punktschweißanlagen
050068

GYRO 360°

10-14 kg
for BPLC/BPLCX
051737for EVOLUTION
051720

BANC DE TRACTION ARRACHE TÔLE - Steel sheet traction bench - Blech-Zugbank zur Festigkeitsprüfung



VALISE DE TEST SOUDURE - Weld test kit - Schweißtestkit im Hartschalenkoffer



CAPTEUR D'EFFORT - Electrode force sensor



GYSTEEL VISION

IDENTIFIEZ VOTRE ACIER - STEEL IDENTIFICATION
- IDENTIFIZIEREN SIE DIE STAHLHÄRTERegister online
test certificate

Bras isolés - Isolated arms - Isolierte Bügel & Classic arms

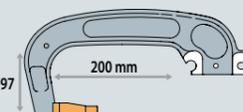
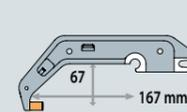
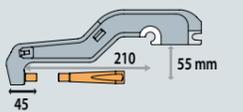
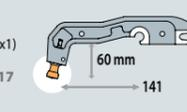
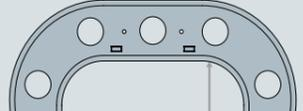
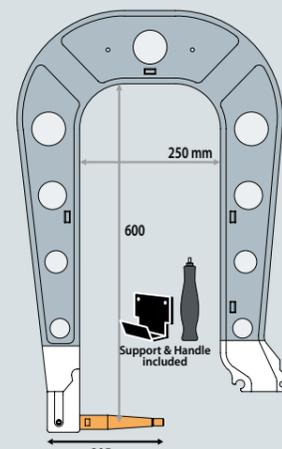
C1 8 bar/550 daN
021402
019140C5 8 bar/550 daN
022393
019294C2 8 bar/550 daN
022386
019133C6 8 bar/300 daN
022409
019775C3 8 bar/550 daN
021419
019157C7 8 bar/550 daN
021433
020009C4 8 bar/550 daN
021426
019164C8 8 bar/550 daN
021440
020016C9 8 bar/550 daN
020078

X Arms - Caps Ø13 mm

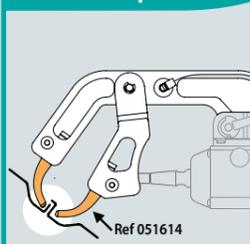
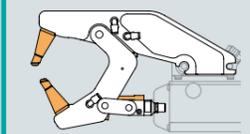
C10 4 bar/150 daN
051638C11 8 bar/550 daN
053649

Arm panel

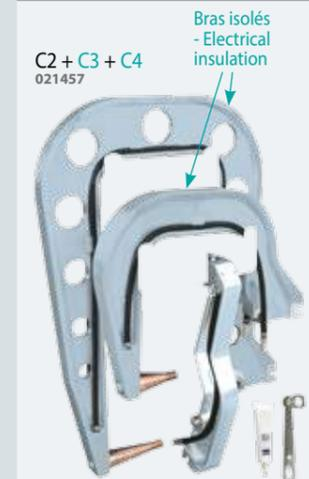
C2 + C3 + C4
019126C2 + C3 + C5 + C6 + C9
050044C2 + C3 + C4
021457



UNIVERSAL CAR BODY RIVETING SYSTEM 8t

(7840 daN)

PNEUMATIC HYDRAULIC

RIVETING SYSTEM

BRAS DE RIVETAGE (HR)

- Riveting arms (HR) - C-Bügel

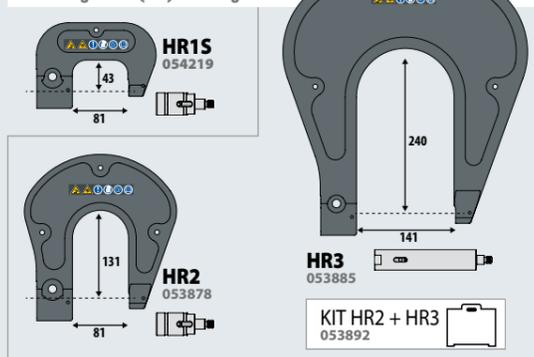

POINTEAU CENTREUR - Special center punch - Spezialkörner



OPTIONS

Support Riveteuse pour changements d'accessoires (bras & matrice)
- Riveting machine support for changing accessories (arms & dies)
- Supportständer
↓ 28 x 40 x 21,5 cm
054158



RIVETS - Rivets - Nieten

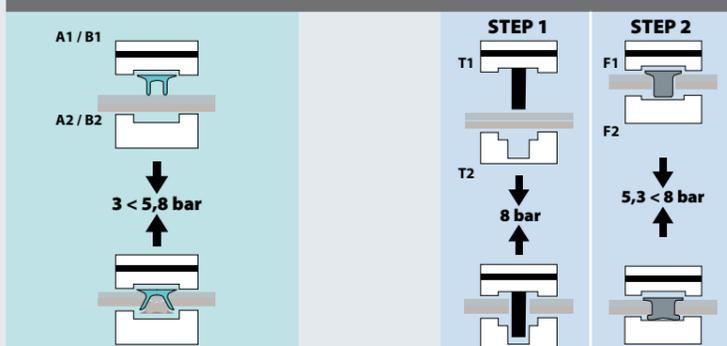

RIVETS AUTO-PERCANTS (RAP)

- Self-piercing rivets (SPR)
- Stanznieten

1	RIVETS ACIER/STEEL/STAHL Ø 3,3 x 3,5 mm 048232 (x200)
	RIVETS ACIER/STEEL/STAHL Ø 3,3 x 4 mm 048249 (x200)
	RIVETS ACIER/STEEL/STAHL Ø 5,3 x 4 mm 048256 (x100)
	RIVETS ACIER/STEEL/STAHL Ø 5,3 x 5 mm 048263 (x100)
2	RIVETS ACIER/STEEL/STAHL Ø 5,3 x 6 mm 048270 (x100)
	RIVETS ACIER/STEEL/STAHL Ø 5,3 x 8 mm 048225 (x100)

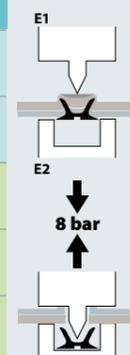

RIVETS FLOW-FORM (RFF)

- Flow-form rivets (FFR)
- Fließ-Form Nieten

	ALU	RIVET Ø 5,6 x 8,1 mm
		RIVET Ø 5,6 x 9,3 mm
		RIVET Ø 5,6 x 10,6 mm
3	ACIER/STEEL/STAHL	RIVET Ø 5,6 x 8,1 mm
		RIVET Ø 5,6 x 9,3 mm
		RIVET Ø 5,6 x 10,6 mm

MATRICES DE RIVETAGE RAP / MATRICE D'EXTRACTION / MATRICES DE RIVETAGE RFF

- Riveting dies SPR - Matrizen - Extracting dies - Riveting dies FFR - Matrizen

A1 Ø 3 mm	B1 Ø 5 mm	E1 E1 (x5) Set 054288	T1	F1
1	2	1 / 2 / 3	3	
A2 Ø 3 mm	B2 Ø 5 mm	E2	T2	F2
A1 + A2 Set 054295	B1 + B2 Set 054301	E1 + E2 Set 054318	T1 + T2 Set 054707	F1 + F2 Set 054714

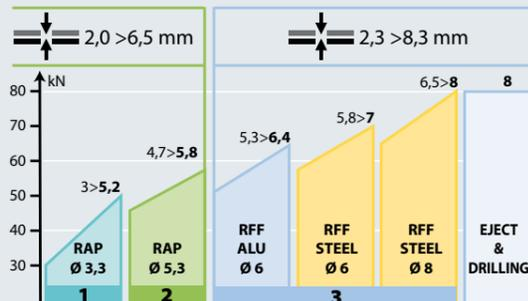

GYPESPRESS 8T

053861



UNIQUE
100%
No Oil Leak
maintenance free, no oil refill

RIVETING SYSTEM



PRESSURE CONTROL - Druckregelung



SPEED CONTROL - Regelung Werkzeuggeschwindigkeit



DISCHARGE LEVER - Auslösehebel

INCLUDED

14	Kit matrices standard (2 clés + centreur inclus)
16	Dies tool box (2 keys + special center punch included) 053694
	HR arm locker
	Strap Sangle Gurt
	HR1 arm 50 x 60 mm
	Poignée Handle Griff
	6 x 50 rivets - Nieten RAP/SPR ACIER / STEEL / STAHL Ø 3,3 x 3,5 mm Ø 3,3 x 4,0 mm Ø 5,3 x 4,0 mm Ø 5,3 x 5,0 mm Ø 5,3 x 6,0 mm Ø 5,3 x 8,0 mm



GYPESPRESS 8t

053861

AIR BAR
8 bar = 8 t
maxi 10 bar

PRESSURE CONTROL
0 > 8 bar

SPEED CONTROL
+ -

58 x 48 x 15 cm

6 kg

11,3 kg

KIT MATRICES RMB 01 - Dies tool box - Matrizen-Kit



For BMW
054240



Pose de rivets auto-perçants Ø 3,3 mm - Application of self-piercing rivets Ø 3,3 mm - Stanzniet-Verpressen Ø 3,3 mm		Pose de rivets auto-perçants Ø 5,3 mm - Application of self-piercing rivets Ø 5,3 mm - Stanzniet-Verpressen Ø 5,3 mm		Extraction de rivets auto-perçants - Extraction of self-piercing rivets - Stanzniet-Auspressen		clé plate	joins
A1	A2	B1	B2	E1	E2		
						x2	x4

KIT MATRICES RMB 02 - Dies tool box - Matrizen-Kit



For Jaguar/Land Rover
054271



Pose de rivets auto-perçants Ø 4,8 mm - Application of self-piercing rivets Ø 4,8 mm - Stanzniet-Verpressen Ø 4,8 mm		Extraction de rivets auto-perçants - Extraction of self-piercing rivets - Stanzniet-Auspressen		Applanissement des tôles - Metal sheet levelling - Blech-Rückverformung		clé plate	joins
B2	B3	E1	E2	D17			
						x2	x4

KIT MATRICES RMB 03 - Dies tool box - Matrizen-Kit



For VW Group
054257



Pose de rivets auto-perçants Ø 3,2 mm et Ø 3,5 mm - Application of self-piercing rivets Ø 3,2 & 3,5 mm - Stanzniet-Verpressen Ø 3,2 & 3,5 mm		Pose de rivets auto-perçants Ø 5,3 mm - Application of self-piercing rivets Ø 5,3 mm - Stanzniet-Verpressen Ø 5,3 mm		Pose de rivets pleins Ø 4,0 mm - Application of solid rivets - Vollniet-Verpressen Ø 4,0 mm		
A1	S3	B1	S7	S8	D8	D9
					x2	

Pose de rivets pleins Ø 6,0 mm
- Application of solid rivets Ø 6,0 mm
- Vollniet-Verpressen Ø 6,0 mm

Extraction de rivets auto-perçants Ø 3,2 mm
- Extraction of self-piercing rivets Ø 3,2 mm
- Stanzniet-Auspressen Ø 3,2 mm

Extraction de rivets auto-perçants Ø 5,3 mm
- Extraction of self-piercing rivets Ø 5,3 mm
- Stanzniet-Auspressen Ø 5,3 mm

D17	S1	D1	D2	D3	D4	S4	D5	S5	clé plate
									x2

Extraction de rivets pleins Ø 6,0 mm
- Extraction of solid rivets Ø 6,0 mm
- Vollniet-Auspressen Ø 6,0 mm

Perçage et formage des tôles pour rivets pleins Ø 4,0 mm
- Metal sheet punching and shaping
- Vollniet-Lochstanzen/Prägen Ø 4,0 mm

Perçage et formage des tôles pour rivets pleins Ø 6,0 mm
- Metal sheet punching and shaping
- Vollniet-Lochstanzen/Prägen Ø 6,0 mm

Perçage et formage des tôles pour rivets POP Ø 4,8 mm
- Metal sheet punching for POP rivets
- Lochstanzen f. Blindniet Ø 4,8 mm

Perçage de tôles Ø 8 mm pour bouchonnage (D12 + D5)
- Metal sheet punching
- Lochstanzen f. Schweissverbindung Ø 8 mm

D13	E2	D10	D11	D15	D16	D6	D7	D12	joins
									x4

KIT MATRICES RMB 04 - Dies tool box - Matrizen-Kit



For Mercedes-Benz
054264



Perçage des tôles Ø 6 mm - Metal sheet punching Ø 6 mm - Lochstanzen Ø 6 mm		Perçage des tôles Ø 8 mm - Metal sheet punching Ø 8 mm - Lochstanzen Ø 8 mm		Extraction de rivets Ø 6 mm - Extraction of rivets Ø 6mm - Niet-Auspressen Ø 6 mm		Extraction de rivets Ø 8 mm - Extraction of rivets Ø 8mm - Niet-Auspressen Ø 8 mm	
T1	T2	T3	T4	E4	E3	E5	
Pose de rivets Flow-Form Ø 6 mm - Application of Flow-form rivets - Setzen v. Fließformnieten				Pose de rivets Flow-Form Ø 8 mm - Application of Flow-form rivets Ø 8 mm - Setzen v. Fließformnieten Ø 8 mm			
Rivets : A1, A2, A3, S0, S1, S2, S3, S4, S5, S6				Rivets : S28, S38, S48, S58, S68		Rivets : S08, S18	
F1	F2	F3	F5	F4	clé plate		
					x2		

PACK RIVETAGE MERCEDES
055421

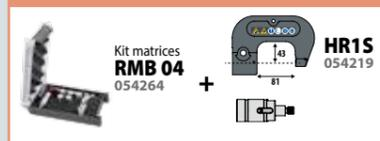

Ne pas utiliser avec :
- Do not use with :
- Nicht kombinierbar mit :



RIVETUSE HYDRO-PNEUMATIQUE RIV 508 - Hydropneumatic nut insert riveter - Hydro-pneum. Blindnietgerät



Effort maximum 21 000 N
livré avec Kit pour pose de rivets
Ø 4,8 à Ø 7,8 mm

055407



SERTISSEUSE HYDRO-PNEUMATIQUE RIV 998 - Hydropneumatic sealing machine - Hydro-pneum. Blindnietmuttergerät



Pour la pose d'écrous à sertir M3 à M12
livré avec accessoires pour écrous à sertir
M3 à M10 (M12 en option)

055414



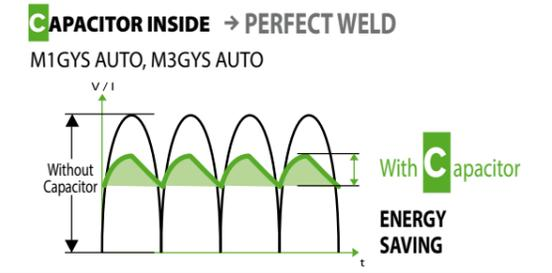
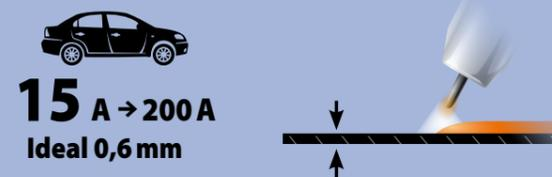

M1GYS AUTO CAPACITOR INSIDE

- with accessories:
- 230V 1~ 032903
 - 208/240V 1~ 032088

T1GYS AUTO 400V 3~

- with accessories:
- 032910

T1GYS AUTO DV 230/400V 3~

- with accessories:
- 032927



OPTIONS

20L / min (FR) 041998 (UK) 040274 (NL) 040267

OPTIMAPRO 30L / min (FR) 043619 (UK) 043633 (EN) 043626 (NL) 043640

30L / min (FR) 041622 (UK) 041646 (DE) 041219 (NL) 041615

Préchauffeur de gaz - Gas preheater for CO₂ pur or CO₂/Ar 230V - power: 25 W max pressure: 200 bar IP 44 - 1.5 kg (FR) 046511 **NEW 2016**

041332

041806

for M3/T3 041493

048874

T3GYS & M3GYS: Housses de protection - Protection cover - Schutzhaube



M3GYS AUTO CAPACITOR INSIDE

- with accessories:
- 230V 1~ 032880
 - 208/240V 1~ 032897

T3GYS AUTO 400V 3~

- with accessories:
- 032958 with accessories: 032941

T3GYS AUTO DV 230/400V 3~

- with accessories:
- 032972



Protection gas
Argon+Co₂ (Steel, Inox)
Argon (ALU/CuSi3/CuAl8)
Co₂PUR

MADE IN P.R.C.	CARMIG	032132	50/60 Hz	AM	min → max	Reg	100 (spoolgun)	200	300	Electronic Control	EN60974-1 (40°C)		Ø mm	Equipement d'origine Original equipment Originalausstattung Equipamiento de fabrica	cm/kg	Protected & compatible power generator (+/-15%)	
			A	A	IA (60%)						X% (I2 max)						
MADE IN FRANCE	M1GYS AUTO	032903	230V 1~	16	15 → 160	6	option	▪	▪	4x	90	140A@15%	0,6+1	0,6/0,8	0,8	47x77x79 / 50	4,5 kVA
	T1GYS AUTO	032088	208/240V 1~	10	15 → 200	7	option	▪	▪	4x	110	150A@25%	0,6+1	0,6/0,8	0,8	47x77x79 / 55	5 kVA
	T1GYS AUTO DV	032927	230/400V 3~	10	15 → 200	7	option	▪	▪	4x	110	150A@25%	0,6+1	0,6/0,8	0,8	47x77x79 / 55	5 kVA
	M3GYS AUTO	032880	230V 1~	16	15 → 160	6	▪	▪	▪	4x	90	140A@15%	0,6+1	0,6/0,8 0,8/1,0	2 x 0,8	60x90x90 / 67	4,5 kVA
	T3GYS AUTO	032897	208/240V 1~	10	15 → 160	6	▪	▪	▪	4x	110	150A@25%	0,6+1	0,6/0,8 0,8/1,0	2 x 0,8	60x90x90 / 72	5 kVA
	T3GYS AUTO DV	032972	230/400V 3~	10	15 → 200	7	▪	▪	▪	4x	110	150A@25%	0,6+1	0,6/0,8 0,8/1,0	2 x 0,8	60x90x90 / 72	5 kVA

MIG / MANUAL
Enter your parameters



Adjust Spot & Delay

MMA



HotStart ArcForce

TIG lift



Post Gas Downslope

MIG / SYNERGIC

Easy to use



Select:

1. material
2. Ø wire
3. position
4. thickness

Adjust arc length



EN 1090

PROMIG 350 G.DV

Generator 40 **350 A**

no accessories
035904

PROMIG 350-4S DUO.DV

Compact DUO 40 **350 A**

no accessories:
035911

Multi PEARL 201-4

20 **200 A** Ø 200/300

PFC FV SR

with accessories:
031821



PROMIG 350-4S

Compact 40 **350 A**

no accessories
035898

Multi PEARL 200-2

20 **200 A** Ø 100/200

PFC FV SR

with accessories:
031944



Multi PEARL 200-4 XL

20 **200 A** Ø 200/300

PFC FV SR

with accessories:
031791



CONNECTION CABLES
FAISCEAUX DE LIAISON

L	AIR COOLED	Ø
5 m	034822	50 mm ²
5 m	034839	70 mm ²
10 m	034853	50 mm ²
10 m	034860	70 mm ²
10 m	045941	95 mm ²

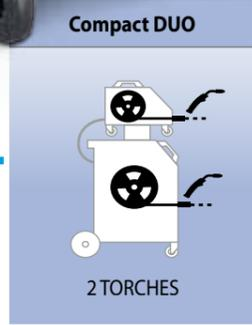
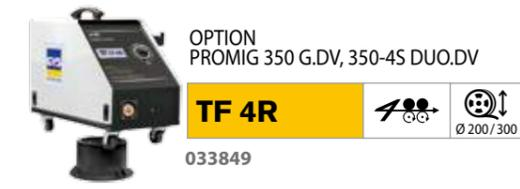

MADE IN FRANCE EN60974-1	50/60 Hz	A	INTEGRATED TECHNOLOGY			I ₂ MMA	I ₂ TIG	min → max	Ø mm	Electronic Control	MIG		EN60974-1 (40°C)	U _o (V)	cm / kg	Protected & compatible power generator (+/-15%)				
			PFC	FV	SR						GAS	NO GAS								
Multi PEARL 200-2	110V 1~ 230V 1~	32 13	■	■	■	10 → 130 10 → 200	10 → 180 10 → 200	20 → 150 20 → 200	■	■	■	0.6 + 1.0	0.9	110 135	150 A @ 22% 200 A @ 20%	85	0.6 / 0.8	0.8	25 x 45 x 35 / 16	7.5 kW
Multi PEARL 200-4 XL	110V 1~ 230V 1~	32 13	■	■	■	10 → 130 10 → 200	10 → 180 10 → 200	20 → 150 20 → 200	■	■	■	0.6 + 1.0	0.9	110 135	150 A @ 22% 200 A @ 20%	85	0.6 / 0.8	0.8	25 x 55 x 44 / 20	7.5 kW
Multi PEARL 201-4	110V 1~ 230V 1~	32 13	■	■	■	10 → 130 10 → 200	10 → 180 10 → 200	20 → 150 20 → 200	■	■	■	0.6 + 1.0	0.9	110 135	150 A @ 22% 200 A @ 20%	85	0.6 / 0.8	0.8		7.5 kW

MADE IN FRANCE EN60974-1	50/60 Hz	A	Ø mm	min → max	200	300	ELECTRONIC CONTROL	Cooling system	EN60974-1 (40°C)			cm / kg	Protected & compatible power generator (+/-15%)
									IA (60%)	X% (I ₂ max)	Reg		
PROMIG 350-4S	400V 3~	16 (20)	—	40 → 350	■	■	■	Air	270	350 A @ 35%	14	50 x 90 x 88 / 102	17 kVA
PROMIG 350 G.DV	230V 3 ~ & 400V 3~	230V: 25 (40) 400V: 16 (25)	—	40 → 350	■	■	■	Air	270	350 A @ 35%	14	50 x 90 x 88 / 102	17 kVA
PROMIG 350-4S DUO.DV	—	—	0.8 + 1.2	40 → 350	■	■	■	Air	—	—	—	59 x 44 x 30	—
TF 4R	—	—	0.8 + 1.2	—	■	■	■	Air	—	—	—	—	—

INVERTER MIG & TRUCK REPAIR MIG



MIG/MAG INVERTER DOUBLE PULSE

400 V · 3 Φ



SIZE N°1 ON MARKET
5" 1/4 ERGONOMIC & EASY

STANDARD MODE
EASY & INTUITIVE

PRO MODE
100% PARAMETERS

Ø 1.0mm Fe_ARG CO2 STD 4T

1.2 +1

U=52V I=215A

OPTION PRO

Ø 1.0mm Al Mg5 ARG PULSE 2T

1.9 1.0 59

U (V) 12.6 -2 0

PRO Prog 2

Ideal Alu & CuAl8/CuSi3

SQS SOFT QUICK START
Vitesse d'accostage contrôlée

SOFT QUICK START

Stable arc / Constant penetration
Arc stable / pénétration constante

Adjustable inductance
Inductance réglable

Soft welding Hard welding

100% Burnback

Splatter free
- Pas de projection
- Keine Spritzer

Difficult Access
- Accès difficile
- Problempositionen

Gap-Bridging
- Refferment de jour
- Spaltüberbrückung

4 DRIVE ROLLERS
Ø 37 mm, MOTOR 75W
Rollers Type C

ELECTRONIC

DSP FULLY DIGITAL
RJ12 - Software update

SYNERGIES UPDATE
- Mise à jour des synergies

SD CARD 050914

NEOPULSE 270

15 **270 A**

no accessories/no trolley :
020337

NEOPULSE 270-T2

15 **270 A**

FV TRI no accessories/no trolley :
021983

NEOPULSE 300

15 **270 A**

FV TRI no accessories/no trolley :
032767

NEOPULSE 300-T2

15 **270 A**

FV TRI no accessories/no trolley :
032729

SCREEN PROTECTION (x5) 044043



OPTIONS

FV TRI FLEXIBLE VOLTAGE



Max 10m³ (50L)

WCT 1.3kW A
400 V, 2~
1300W, cooling unit (5)
020344

WCT 1.3kW C
230 V, 2~
1300W, cooling unit (5)
032781

Potence -Cable support 032842

INCLUDED Connection 034273

MADE IN FRANCE EN60974-1	50/60 Hz	A	Ø mm	min → max	A	FV TRI	SPOOLGUN	PUSHPULL	200	300	Cooling system	Equipement d'origine Original equipment Originalausstattung Equipamiento de fabrica		EN60974-1 (40°C)		cm / kg	Protected & compatible power generator (+/-15%)
												IA (60%)	X% (I2 max)	IA (60%)	X% (I2 max)		
NEOPULSE 270	400V · 3~	16	0,6 → 1,2	15 → 270	—	—	—	—	■	■	Air	0,8 / 1,0 mm	190	270A@20%	38x52x64 / 37	12,5 kVA	
NEOPULSE 270-T2	230V · 3~	20	0,6 → 1,2	15 → 220	■	OPTION	OPTION	■	■	■	Air	0,8 / 1,0 mm	190	220 A @ 40%	38x52x64 / 39	10 kVA	
	400V · 3~	16	0,6 → 1,2	15 → 270	■	—	—	■	■	■	Air	0,8 / 1,0 mm	190	270 A @ 20%	38x52x64 / 39	12,5 kVA	
NEOPULSE 300	230V · 3~	20	0,6 → 1,2	15 → 240	■	—	OPTION	■	■	■	Air	0,8 / 1,0 mm	220	240 A @ 60%	38x52x64 / 41	10 kVA	
	400V · 3~	16	0,6 → 1,2	15 → 270	■	—	—	■	■	■	Air	0,8 / 1,0 mm	240	270 A @ 40%	38x52x64 / 41	12,5 kVA	
NEOPULSE 300-T2	230V · 3~	20	0,6 → 1,2	15 → 240	■	—	OPTION	■	■	■	Air	0,8 / 1,0 mm	220	240 A @ 60%	-	10 kVA	
	400V · 3~	16	0,6 → 1,2	15 → 270	■	—	—	■	■	■	Air	0,8 / 1,0 mm	240	270 A @ 40%	-	12,5 kVA	

INVERTER MIG • NEOPULSE



BOBINES DE FIL - Welding wire reels - Drahtspulen - Rollos de hilo - Draadbobbijn - Bobines de filo



	kg	100mm	Ø				NORMES - Norms - Normen - Norma		
			0.6 mm	0.8 mm	1.0 mm	1.2 mm	AWS	EN	DIN
Acier - Steel - Stahl - Acero - Staal - Aço (SG2)	0.9	100 mm	086593	086609					
	5	200 mm	086111	086128	086135				
	15	300 mm	086166	086227	086234	086241	AWS 5.18 : ER 70S-6	EN ISO 14341-A : G46 4M G351	DIN 8559 : SG2
	18	300 mm		086272 (15kg)	086289	086296			
Galva (G2Ti)	5	200 mm	086760	086777					
Alu (AlMg3)	2	300 mm				086517			
	7	300 mm				086500			
Alu (AlMg5)	0.5	100 mm		086548					
	2	200 mm		086555	086562				
	7	300 mm			086524	086531			
Alu (AlSi5)	0.5	100 mm		086685					
	2	200 mm		086678		086142	086159		
Alu (AlSi12)	0.5	100 mm							
	2	200 mm				086067	086074		
Inox - Stainless - Edelstahl (308LSi)	1	100 mm		086616					
	5	200 mm		086579					
Inox - Stainless - Edelstahl (316LSi)	5	200 mm		086326					
	1	100 mm		086692					
Cusi3 HLE - UHTS (Boron Steel)	5	200 mm		086647	086654				
	5	200 mm		086661	086197	086180			
CuAl8 HLE - UHTS (Boron Steel)	15	300 mm							
	4.5	200 mm		Ø 0.9 = 086623		086630			
Fil fourré, Cored wire, Fülldraht, Hilo tubular Acier - Steel - Stahl NO GAS	0.9	100 mm		Ø 0.9 = 086104					
	16	300 mm							
Rechargement Acier 60 HRC									

GALETS - Rollers - Vorschubrollen - Rollen - Rodillos - Wielen - Roletes

	Ø	TYPE A		TYPE B		TYPE C	
		Ø30mm	Ø9mm	Ø37mm	Ø9mm	Ø37mm	Ø19mm
Acier - Steel - Stahl - Acero - Staal - Aço - Inox - Stainless	Ø 0,6 / 0,8	(x1)	042339	(x1)	042087	(x2)	041738
	Ø 0,8 / 1,0	(x1)	041189	(x1)	042100	(x2)	042094
	Ø 1,0 / 1,2			(x1)	042179	(x2)	042117
	Ø 1,2 / 1,4					(x2)	039780
	Ø 1,2 / 1,6					(x2)	041752
Alu	Ø 0,8 / 1,0	(x1)	041196	(x1)	042155	(x2)	042148
	Ø 1,0 / 1,2			(x1)	042186	(x2)	042162
	Ø 1,2 / 1,6					(x2)	041776
	Ø 0,9 / 1,2	(x1)	042346	(x1)	042131	(x2)	042124
Fil fourré - Corred wire	Ø 1,6 / 2,4				(x2)	040519	
Fil fourré - Corred wire	Ø 0,9	Smartmig 110 (Ø 25 mm)	(x1)	044081			

PINCE SPÉCIALE MIG/MAG - ORIGINAL FIX - Special MIG/MAG plier - Spezial MIG/MAG Zange - Pinza especial MIG/MAG

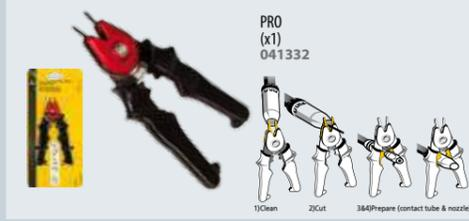

SUPPORT TORCHE MAGNETIQUE - MIG torch stand with magnetic base

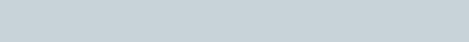

KIT SOUDAGE NO GAZ Ø 0,9 - No Gas Welding Kit Ø 0,9



COFFRETS - Boxes - Kästen - Cajas - Kistjes - Estojos

MB 15 (150 A) 041226	x3	x5	x5 (M6-Ø0,6) x5 (M6-Ø0,8) x5 (Alu - M6-Ø0,8)	x3
MB 25 (250 A) 041233	x5	x3	x5 (M6-Ø0,8) x5 (M6-Ø1,0) x5 (Alu - M6-Ø1,0)	x3
MB 36 (350 A) 041417	x2	x3	x5 (M8-Ø1,0) x5 (M8-Ø1,2) x5 (Alu - M8-Ø1,0) x5 (Alu - M8-Ø1,2)	x2

TORCHES - Torches - Brenner - Antorcha - Lastoort - Tocha

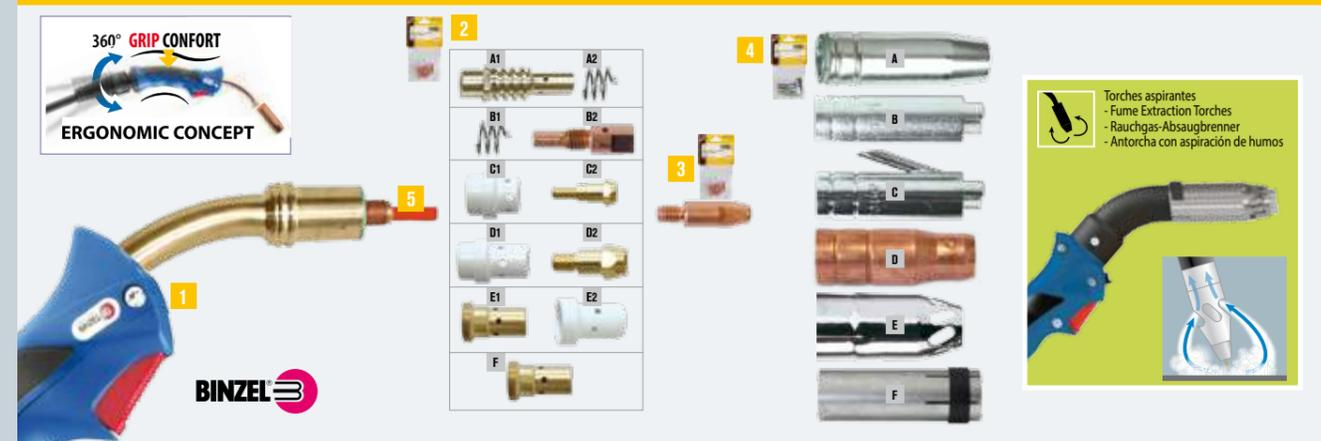

	ACIER / INOX - Steel/Stainless steel - Stahl/Edelstahl				LIQUID		ALU - Aluminium - Aluminio				
	AIR	250 A	350 A	450 A	300 A	500 A	AIR	250 A	350 A	LIQUID	500 A
1 TORCHES COMPLETES - Complete Torches - Brenner - Antorcha - Lastoort - Tocha	150 A	250 A	350 A	450 A	300 A	500 A	150 A	250 A	350 A	300 A	500 A
2 SUPPORTS TUBE CONTACT & DIFFUSEURS - Tip adaptors & diffusers	A1 (x3) 042902	B1 (x5) 042995	D1 (x3) 043008	F (x3) 045484	C1 (x3) 043589	E1 (x5) 042940	A1 (x5) 042902	B1 (x5) 042995	D1 (x3) 043008	C1 (x3) 043589	E1 (x5) 042940
3 TUBES CONTACTS - Contact tips - Kontaktrohre - Tubo de contacto - Contactbuis - Pontas de contacto	A2 (x10) 042988	B2 (x5) 042919	D2 (x5) 042926		C2 (x5) 043541	E2 (x3) 043022	A2 (x10) 042988	B2 (x5) 042919	D2 (x5) 042926	C2 (x5) 043541	E2 (x3) 043022
4 BUSES - Gas nozzles - Düsen - Tubo - Nippel - Bicos	A (x3) 041875	E (x1) 043084	A (x3) 041882	E (x1) 040571	(x3) 041783	E (x1) 040588	A (x3) 045491	A (x3) 043534	A (x3) 042315	E (x1) 040588	Ø 12 A (x3) 041875
5 GAINES - Torch liners - Mantel - Funda - Drahtseelen - Folha	3 m		041592				041578				

	ACIER / INOX						ALU				
	150 A	250 A	350 A	450 A	300 A	500 A	150 A	250 A	350 A	300 A	500 A
1 TORCHES COMPLETES	A	B	D	F	C	E	A	B	D	C	E
2 SUPPORTS TUBE CONTACT & DIFFUSEURS	M6	M6	M8	M8	M6	M8	M6	M6	M8	M6	M8
3 TUBES CONTACTS	Ø0.8	Ø1.0	Ø1.2	Ø1.2	Ø1.2	Ø1.2	Ø0.8	Ø1.0	Ø1.2	Ø1.2	Ø1.2
4 BUSES	150A - 60%	200A - 60%	290A - 60%	450A - 60%	270A - 100%	380A - 100%	150A - 60%	200A - 60%	290A - 60%	270A - 100%	380A - 100%
5 GAINES	GRIP 3m	GRIP 3m	GRIP 3m	GRIP 3m	GRIP 3m	GRIP 3m	GRIP 3m	GRIP 3m	GRIP 3m	GRIP 3m	GRIP 3m
Ref.	041424	043268	043251	040700	040922	040540	040687	040946	040557	045392	040694
	043275	041004	040564	041462	040724	040939	040731	040953	040748	043282	046160
											041097

	ACIER / INOX						ALU				
	150 A	250 A	350 A	450 A	300 A	500 A	150 A	250 A	350 A	300 A	500 A
2 SUPPORTS TUBE CONTACT & DIFFUSEURS	A1 (x3) 042902	B1 (x5) 042995	D1 (x3) 043008	F (x3) 045484	C1 (x3) 043589	E1 (x5) 042940	A1 (x5) 042902	B1 (x5) 042995	D1 (x3) 043008	C1 (x3) 043589	E1 (x5) 042940
3 TUBES CONTACTS	A2 (x10) 042988	B2 (x5) 042919	D2 (x5) 042926		C2 (x5) 043541	E2 (x3) 043022	A2 (x10) 042988	B2 (x5) 042919	D2 (x5) 042926	C2 (x5) 043541	E2 (x3) 043022

	ACIER / INOX						ALU				
	150 A	250 A	350 A	450 A	300 A	500 A	150 A	250 A	350 A	300 A	500 A
3 TUBES CONTACTS	Ø0.6	Ø0.8	Ø1.0	Ø1.2	Ø1.4	Ø1.6	Ø2.4	Ø0.6	Ø0.8	Ø1.0	Ø1.2
4 BUSES	150A Ø12	250A Ø15	350A Ø16	450A	300A Ø17	500A Ø16	150A	250A Ø15	350A Ø16	300A	500A Ø16
	A (x3) 041875	E (x1) 043084	A (x3) 041882	E (x1) 040571	(x3) 041783	E (x1) 040588	A (x3) 045491	A (x3) 043534	A (x3) 042315	E (x1) 040588	Ø 12 A (x3) 041875
	B (x1) 041851										B (x1) Ø 12 041851
	C (x1) 041523										F (x3) Ø 16 046214
	D (x1) 041868										

	ACIER / INOX						ALU				
	150 A	250 A	350 A	450 A	300 A	500 A	150 A	250 A	350 A	300 A	500 A
5 GAINES	3 m		041592				041578				
	4 m		041837				044050				
	3 m		041608				041585				
	4 m		041844				044067				
	3 m		418417				044074				
	4 m		418424								
	4 m		040526								

	ACIER / INOX						ALU				
	150 A	250 A	350 A	450 A	300 A	500 A	150 A	250 A	350 A	300 A	500 A
5 GAINES	3 m		041592				041578				
	4 m		041837				044050				
	3 m		041608				041585				
	4 m		041844				044067				
	3 m		418417				044074				
	4 m		418424								
	4 m		040526								

HELMETS

TEINTE SHADE 9/13

EN 175-EN 379



LCD AUTOMATIC TECHNOLOGY	BASIC		PRO		PRO +	PRO +	EXPERT		EXPERT +		
MODEL	TECHNO	MASTER	PROMAX	EXPERT	HERMES	ZEUS	ERGOTECH	GYSMATIC	SPACEVIEW	NAVITEK	
REF	042544	040861	(gold) 045767 (silver) 045774	(carbon) 040878 (blue) 042216	040908 (silver) 040885 (red) 040892 (gold)	(fire) 044098 (cosmic) 044104	(silver) 044173 (black) 045477	043909 046818	040717	045842 +G VISOR 045835 +G VISOR / DIGITAL	
□→■	0.30 ms	0.30 ms	0.25 ms	0.30 ms	0.30 ms	0.20 ms	0.20 ms	0.10 ms	0.10 ms	0.20 ms	0.10 ms
▨	4 - 9 > 13	4 - 9 > 13	4 - 9 > 13	4 - 9 > 13	4 - 9 > 13	5 > 9 9 > 13	5 > 9 9 > 13	4 - 9 > 13 4 - 5 > 13	5 > 9 9 > 13	9 > 13	5 > 8 9 > 13
↻	1/2/1/1	1/2/1/2	1/1/1/2	1/1/1/2	1/1/1/3	1/1/1/2	1/1/1/2	1/1/1/2 1/2/1/1	1/1/1/2	1/1/1/2	
MEMORY & REGULATIONS								ELECTRONIC			
↔	92x42 mm	92x42 mm	100x49 mm	98x43 mm	98x43 mm	XL : 100x67 mm	XL : 100x67 mm	100x60 mm 100x83 mm	XXL : 100x93 mm	93 mm	XL : 100x50
)))	2	2	2	2	2	4	4 HIGH SENSITIVITY	4 HIGH SENSITIVITY	4 HIGH SENSITIVITY	4 HIGH SENSITIVITY	
↻		✓	✓	✓	✓	✓	✓	✓	✓	✓	
□→■ HF								✓		nc	
⚡	☀	☀	☀	☀ + 2 🔋 (CR 2032)	☀ + 2 🔋 (CR 2032)	☀ + 2 🔋 (CR 2450)	☀ + 2 🔋 (CR 2450)	☀ + 2 🔋 (CR 2450) ☀ + 1 🔋 (CR 2450)	☀ + 2 🔋 (CR 2032)	☀ + 2 🔋 (CR 2330)	
🔄	Simple	Simple	Simple	Simple	Simple	Simple	Multi	Simple	Multi	Simple	
👤	440 g	450 g	385 g	510 g	510 g	515 g	560 g	450 g 460 g	530 g	590 g	621 g
LABEL	TOOLiT	TOP ARC	TOOLiT	TOOLiT	TOOLiT	TOOLiT	TOP ARC	GYS		TOOLiT	GYS

VERRES - Lense - Schutzgläser

👁	110x90	x5	040816	116x89.5	x5	040779	226x106	x5	045781	111.2x91	x5	040793	111.2x91	x5	040793	114x133	x10	043893	114x133	x10	043893	114x133	x10	043893	114x133	x10	043893	110x97	x10	045798
	95.5x50.5	x5	040854	103.5x53	x5	040786	104x55	x5	040847	103.6x54	x5	040809	103.6x54	x5	040809	103.7x69.5	x5	043695	103.7x69.5	x5	043695	G : 106x66	x10	043886	104x96	x5	043596	98x47	x10	045804
																						XL : 106x89.5	x10	046825			103x53	x10	DIGITAL 045811	



PLASMA CUTTER

1 Ø



Kompressor
INSIDE

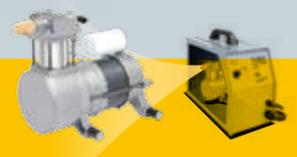

CUTTER 25 K
25 A ALU 4 mm
INOX/STEEL 6 mm

CUTTER 35 KF
35 A ALU 8 mm
INOX/STEEL 12 mm

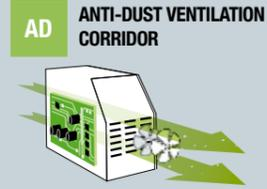
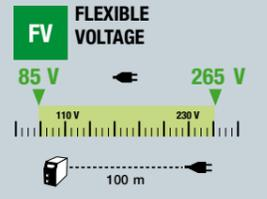
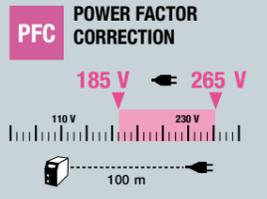

with accessories:
030947
ERGO CUT S25K

with accessories:
031036
ERGO CUT S35K

with accessories:
030985
ERGO CUT S45

with accessories:
031043
ERGO CUT S45



AIR FILTER



INCLUDED:
8 mm
10 mm

ACCESSOIRES / ACCESSORIES

CONSOMMABLES / CONSUMABLES

Chariot/Trolley/Fahrgewagen



ERGO CUT	S 25K			S 35K			S 45		
	Max Cut	Clean Cut		Max Cut	Clean Cut		Max Cut	Clean Cut	
x4 040182	x1	x4 040229	x1	x4 040236	x1	x10 040212	x3	x10 040212	x3
x10 040151	x3	x2 040175	x1	x2 040175	x1	x10 040168	x3	x10 040168	x3
Coffret - Box	039971			039964		039957			



Plasma Cutter
- Filter cartridge 039728
- Filter cartridge 039735

CUTTER	Code	Voltage	I ₂	Cut (mm)			INTEGRATED TECHNOLOGY				AIR SYSTEM			EN 60974-1 (40°C)		Height	Weight	Power	Capacity
				Acier/Steel	Alu	Alu	PFC	FV	AD	KOMPRESSOR INSIDE	mini	ideal	maxi	IA 60%	X% I2 max				
CUTTER 25K	030947	230V 1~	16	5+25	6	4	4	3	—	—	—	—	—	—	—	—	—	4,1 kW	5,9 kVA
CUTTER 35KF	031036	230V 1~	16	10+35	12	8	8	6	—	—	—	—	—	—	—	—	—	8 kW	10 kVA
CUTTER 31FV	030985	230V 1~ 110V 1~ 230V 1~	16 32 16	5+30 5+30 10+40	10 8	8 7	5	—	—	—	—	—	—	—	—	—	—	6 kW	7,5 kVA
CUTTER 40FV	031043	230V 1~ 110V 1~	16 32	10+40 10+30	15 10	10 10	8	—	—	—	—	—	—	—	—	—	—	8 kW	10 kVA

INDUCTION HEATING

1 Ø or 3 Ø



POWERDUCTION 50L
5 200 W

no accessories:
053410



POWERDUCTION 160L
16 000 W

no accessories:
053472



Protection ferrite
054844



Potence - Cable support
Powerduction 50L only
052284

Colle-Stick bi-composant Power Epoxy 150°C
054851

OPTIONS

50L	053441	053458
50L (new)	053762	053823
50L (old: 053427) →		053434
160L	053748	053755

CE NORM. 60974/1	50 Hz	A	W	kHz	INTEGRATED TECHNOLOGY	Liquid Cooling	Cable L (m)		cm	kg
							Inductor	cm		
POWERDUCTION 50L	230V, 1~	25 mini	5 200	20+40	—	—	8	3	103 x 57 x 50	65
POWERDUCTION 160L	400V, 3~	24 mini	16 000	15	—	—	10	4	120 x 60 x 50	190



GYSDUCTION AUTO

2 400 W

PFC FV

COMPLETE



055490

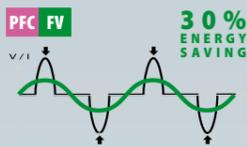
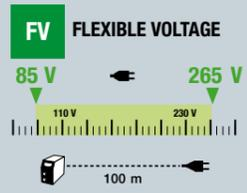
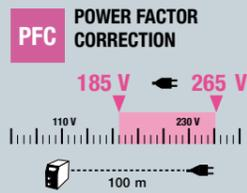

Débosselage rapide et sans peinture
- Fast and paintless dent pulling
- Lackschadenfreies Ausbeulen
054776



Update kit for Gysduction Auto < 05/2015 597251



Inducteur spirale
- Spiral inductor
- Spiralinduktor
054783

NEW
04/2016

INCLUDED

Spirale - Coil - Spiralförmiger draht
Ø 18 mm 054806
Ø 24 mm 054790
Ø 30 mm 055469
Fil tressé enroulable - Flexible wrappable wire - Flexibel geflochtener draht
800 mm 054813
Fil droit rigide - Straight rigid wire - Steif gerade draht
800 mm 054868

OPTION

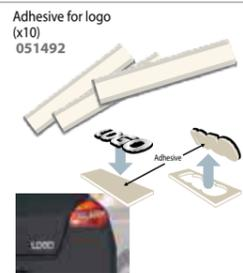

 MADE IN FRANCE	 50 Hz	 A	 W	 kHz	 PFC	 FV	 Liquid Cooling	 Cable L (m)	 Inductor	 cm	 kg

PACKS GYSDUCTION AUTO

GYSDUCTION AUTO	GYSDUCTION AUTO	Plastic wedges 051294	Burn off Inductor Décapage - Burn off - Entfernen 053373	Body Inductor Décollage - Removal - Ablieben 053359	Bolt Inductor Dégrillage - Heating - Lösen 053366	Remote control Télécommande - Fußschalter 055490	Trolley SPOT 800 051331	Cable support 052284	Dent pulling Inductor Débosselage - Dent pulling - Ausbeulinduktor 054776
PROLINER AUTO	048775	■	■	■	■	■	■	■	■
COMPLETE AUTO	053380	■	■	■	■	■	■	■	■
MECA AUTO	048812	■	■	■	■	■	■	■	■
BODY SHOP AUTO	048799	■	■	■	■	■	■	■	■
GLASS AUTO	048805	■	■	■	■	■	■	■	■
DENT REPAIR AUTO	054981	■	■	■	■	■	■	■	■

RÉPARATION PARE-BRISE - Windscreen repair - Demontage von Windschutzscheiben

SYSTÈME DE DÉCOUPE PARE-BRISE A CLIQUET - Windshield Cutting kit - Kit zum Lösen von Windschutzscheiben

054738



NEW

KIT DÉCOUPE JOINT DE PARE-BRISE - Windscreen Joint-cutting Kit - Scheibentrenn-Werkzeug-Set

051898 238,00 €HT



Corde à piano carré (50m)
- Windscreen seal cutting wire (square)
- Vierkant-Draht, 50m Rolle
051881 265€HT

Corde à piano torsadé (22m)
- Windscreen seal cutting wire (twisted)
- Plano-Schneiddraht, gedreht, 22m Rolle
051911 88€HT

OUTIL DÉCOUPE PARE-BRISE - Windshield Cutting Tool - Windschutzscheiben-Ausglas-Set

051935 68,80 €HT



PROTECTIONS TABLEAU DE BORD - Dashboard Protector - Armaturenbrett Schutz

053120 41,30 €HT



KIT VENTOUSE ET SANGLE - Suction Cup and Strap Kit - Saugnapfheber

051966 88,80 €HT



SATELLITE INTELLIGENT - Smart Satellite - Satellite Komplett-Kit

The best from **Autorobot**
www.autorobot.com/pdf/7148_ENG.pdf
MADE IN FINLAND



PACK SATELLITE

= 1 + 2 + 3 + 4 + 5 + 6

= 052727

1 SATELLITE
- Satellite - Satellite Basisbügel-Set

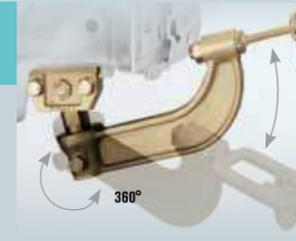

2 KIT MAC PHERSON (A)
- Mac Pherson Kit - Befestigungs-
Federbein (McPherson)



3 BARRE POUR TIRER/POUSSER
- Push/Pull Bar
- Zug/Druck-Stangenset



4 SATELLITE (B)
- Bügelverlängerung



5 SANGLE DE SÉCURITÉ
- Safety Strap - Sicherungsgurt



6 DOUBLE PINCE SATELLITE (C)
- Double Clamp Satellite
- Satellite Doppelklemme



PINCE DE TIRAGE MULTI-USAGE
- Versatile pulling clamp
- Multifunktions-Zugklemme



KIT MARTEAU INERTIE - Inertia hammer kit - Ausziehhammer kit

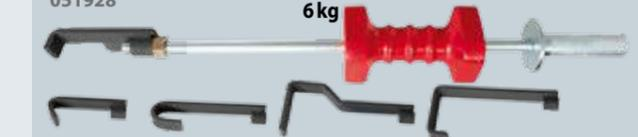

COFFRET VÉRIN HYDRAULIQUE - Hydraulic cylinder kit - Hydraulischer Drucksatz



OUTILS DE TIRAGE - Frame Straightening - Ziehwerkzeuge

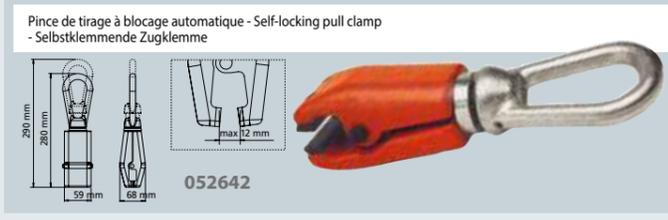
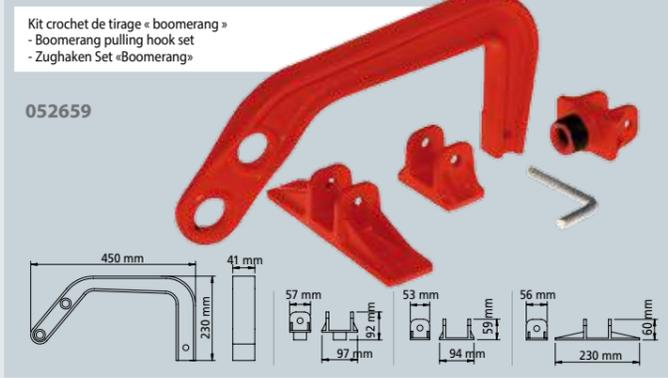

BARRE D'ANCRAGE - Anchor bar - Türspanner

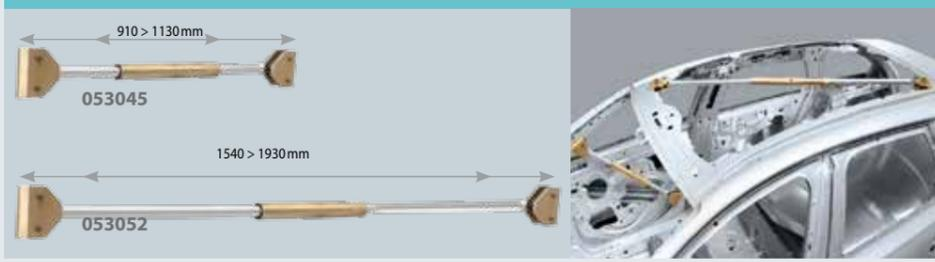

MESURES - Measuring tools - Vermessung

GYSMETER, Electronic measurements



RAIL SAVER

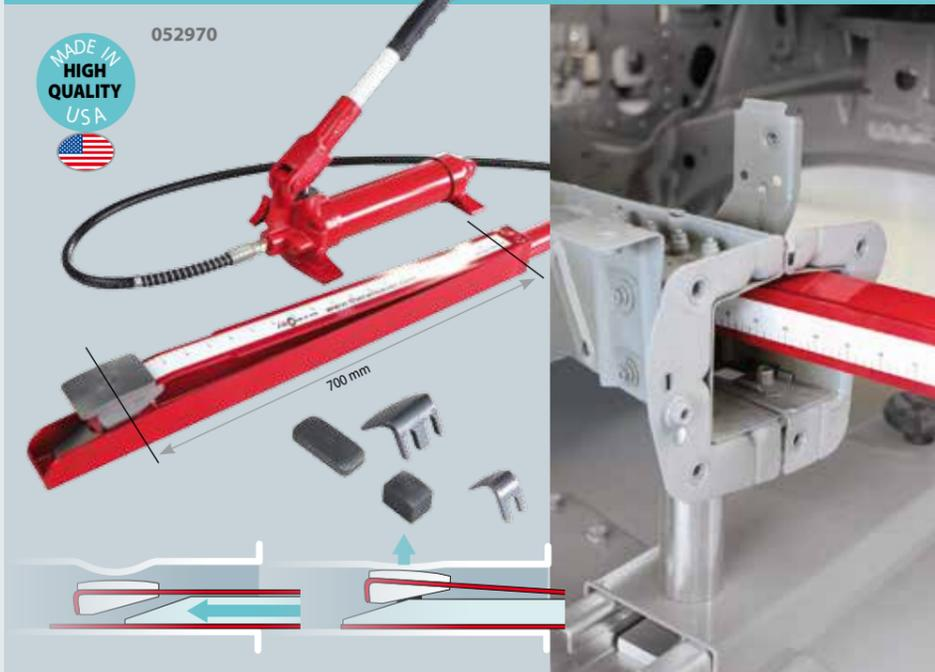

BODYMETER, Mechanical Measurements



GYS HAND TOOLS - Ausbeulwerkzeug

MADE IN HIGH QUALITY GERMANY

053298, 053311, 053328, 053342, 053335, 053281, 051485, 051461, 051478, 051133, 051430, 051416, 051454, 051409, 051447, 051423, (8 dents/pouce - 8 teeth/inch) 052574

JAUGES DE POSITIONNEMENT - Gapping gauges - Spaltmaße

054752

RÉPARATION PARE-CHOC - Bumper repair - Reparatur von Stoßstangen

AGRAFEUSE POUR RÉPARATION PARE-CHOC - Hot stapler for bumper repair - Stoßstangen Reparatur Kit

052925, MADE IN TAIWAN

PORTABLE
Sur batterie - Battery operated

048676, MADE IN TAIWAN

INCLUDED: x20, x20, x20, x20, x20

Included N (x100)

JEU DE 4 BURINS EN NYLON - Set of 4 nylon chisels - 4 Kunststoffmeißel

273mm

19mm (x1), 22mm (x1), 25mm (x1), 38mm (x1)

054745

OUTILS DE FORME - Forming tools - Formgebungswerkzeuge

051195

180 x 70 x 65 mm, 280 x 95 mm, 280 x 95 mm, 75 x 65 mm

EASYPULLER (CARE & MAINTENANCE)

054011

MADE IN HIGH QUALITY USA

900 g

OUTIL DE POINÇONNAGE OBLONGS - Oval hole punch - Langlochkarosserieblechzange

6 mm, 20 mm

2,2 kg, MADE IN DENMARK

052437

REDRESSEUR DE CHARNIÈRE DE PORTE - Door hinge straightener - Türgelenkausrichter

051102

40 mm max

2,2 kg

PINCES - Clamps - Fixier-Klemmen

050242

(x16 = 3 +3 +5 +5)

050266

(x6) 050112

JAUGE DE PROFIL - Contour Gauge - Konturenlehre

052840

250 mm

PINÇES DE MAINTIEN BORD À BORD - Positioning clamp - I-Stoß-Lehre

(x4) 043190

Agrafes - staples

052413	=	x 50	+	x 50	+	x 50	+	x 50	+	x 50
--------	---	------	---	------	---	------	---	------	---	------

Ø 0,6, Ø 0,6, Ø 0,8, Ø 0,8, Ø 0,8

Agrafes prédécoupées - Pre-cut staples

x 100 047990	x 100 047983	x 100 047976	x 100 047969	x 100 047952
Angle interne étroit - Inside corner	Alignement de fissure - Crack alignment	Fissure importante - Large crack	Angle interne - Internal angle	Angle externe - External angle

Prédécoupé - Pre-cut

COFFRET DE RÉPARATION DES PLASTIQUES AUTOMOBILES - Brazing automotive plastics repair kit - Kunststoff Reparatur Kit

052932, 052963

MADE IN BELGIUM

25 x 12,5 cm - x2 052949

Spray refroidisseur - Freezer spray

-50°C, 400 ml

(x12) 048898

COFFRET DÉCAPEUSE PNEUMATIQUE - Pneumatic surface remover Kit - Drucklufttroster-Box inkl. Zubehör

051775



Speed rpm	Power W	dB	Air consumption l/min	Air pressure bar	↔ cm	⚖ kg
4000	500	86	102	6,2	280	1,2

PONCEUSE À BANDE - Air belt sander - Druckluft Bandschleifer

052819

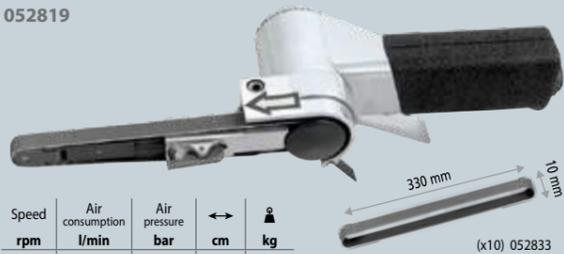

Speed rpm	Air consumption l/min	Air pressure bar	↔ cm	⚖ kg
16000	171	6,3	26	0,9

PERCEUSE MANDRIN AUTOMATIQUE

- Automatic Mandrel Drill - Druckluftbohrmaschine m. Schnellspannfutter

051799



Speed rpm	Power W	dB	Air consumption l/min	Air pressure bar	↔ cm	⚖ kg
800	300	92	170	6,2	18	0,9

MINI-MEULEUSE À RENVOI D'ANGLE - Mini Angle Grinder - Mini-Druckluftwinkelschleifer geräuschgedämpft

051867



Speed rpm	Power W	dB	Air consumption l/min	Air pressure bar	↔ cm	⚖ kg
15000	200	86	85	6,2	18	0,75

MINI-FRAISEUSE À RENVOI D'ANGLE

- Mini Angle Milling Machine - Mini-Winkelschleifer

051836



Speed rpm	Power W	dB	Air consumption l/min	Air pressure bar	↔ cm	⚖ kg
18000	500	81	85	6,2	18	0,7

MINI-MEULEUSE - Mini disc sander - Druckluftschleifer

051829



Speed rpm	Power W	dB	Air consumption l/min	Air pressure bar	↔ cm	⚖ kg
18000	200	83	171	6,2	12	0,7

SCIE COUPE TÔLE DROITE ET LIME - Saw for Straight Cut and File - Druckluftsäge und Feile

051805



Speed rpm	Power W	dB	Air consumption l/min	Air pressure bar	↔ cm	⚖ kg
5000	—	85	255	6,2	10	0,8

PINCE À SOYER ET À TROUER, Ø5MM PNEUMATIQUE - Pneumatic flange / ø5 mm punching tool - Pneumatische Loch- und Absetzange Ø 5 mm



2 in 1

052543

POINÇONNEUSE PNEUMATIQUE OBLONG - Pneumatic oval punching tool - Pneumatische Langloch-Blechzange

053182



052437
OUTIL DE POINÇONNAGE OBLONGS
- Punching tool for oval holes - Langlochkarosserieblechzange

DÉPOINTEUSES - Spot remover - Druckluft-Schweißpunktbohrer

GYSPT DRILL
050464

Included : Tungsten Carbide for BORON/UHSS ø8 (x1) + ø10 (x1)



Forets de dépointage - Spot remover drill - Schweißpunktfräse

Tungsten Carbide for BORON/UHSS

Speed rpm	Power W	dB	Air consumption l/min	Air pressure bar	↔ cm	⚖ kg
800	400	85	140	6,5	35	2,3

Affuteur de forêt de dépointage - Drill bit grinder - Schleifer für Schweißpunkt-Fräser

Drill grinder 052147



✓ STEEL
✓ VHSS

HIGH QUALITY

Made in Japan

DÉPOINTEUSE POUR CORDON LASER ACIER & ALU - Laser cord metal sheet cutter (nibbler) - Trennwerkzeug für Lasernähte



054165

STEEL Included 054172

ALU Included 054189

DÉPOINTEUSE POUR CORDON LASER

- Laser cord metal sheet cutter (nibbler) - Trennwerkzeug für Lasernähte



050099

050082

Indispensable pour Necessary for : Citroën C4 / VW / BMW ...

RENOV'POLYCARBONATE - Compressed air polisher - Druckluftpolierer



Complete pack 052086

2 SPEED

052055

052062

052079

Ø 76

P 500 (x 10)
P 800 (x 10)
P 1500 (x 10)
P 3000 (x 10)

P 500 x 50	052017
P 800 x 50	052024
P 1500 x 50	052031
P 3000 x 50	052048



TRÉTEAUX - Frames support - Klappböcke

040601
100,5 x 112 cm - 5,5 kg
35 x 95 x 106 cm



4 pieds coudés
Idéal sur caillbotis
- Bent feet for grating
- Abgewinkelte Standfüße:
Sicherer Stand auf Gittern u.ä.

040311
104,5 x 117 cm - 8,1kg
32 x 10 x 106 cm



4 ventouses
Dépose vitrages
- Suction pad for glazing
- Gummiteiler zur Fixierung
von Glasscheiben



040250
100 x 105 cm
- 7kg
32 x 10 x 106 cm

Léger et très maniable
Spécial travaux à l'horizontal
- Light and easy to handle
- Ideal for horizontal works
- Speziell geeignet für Arbeiten
in horizontaler Position

040304
104,5 x 108,8 cm - 8,1kg
32 x 10 x 106 cm



Chainette réglable
- Adjustable catenary



Mousse de protection
- Protecting foam



Antidérapants
- Non-slip base

SUPPORT PARE-CHOC

- Rotary element support - Lackierständer für Stoßstange, einstellbar

052376
91 x 105 cm - 7,6 kg
60 x 11 x 75 cm



Adapté aux coques de rétroviseurs
- Adapted to wing mirror covers
- Geeignet für Außenspiegel

SUPPORT ÉLÉMENT ROTATIF

- Rotary element support - Lackierständer für Stoßstange, einstellbar



360°

Verrouillage de l'axe
- Locking of the axis
- Verriegelung der Achse

052611
200 x 101 cm - 17,5 kg
35 x 15 x 110 cm

CHARIOT DE STOCKAGE - Storage trolley

- Lagerrollwagen



040243
71 x 90 x 197cm - 41 kg
x2: 91 x 147 x 6 cm
+ 69 x 93 x 44 cm

CHARIOT DE LUXE MAROUFLAGE - Premium

masking machine



x 4
120 cm,
Ø 75 mm

039742
135 x 51,5 x 11,5 cm - 28 kg
130 x 50 x 54 cm - 30 kg

DÉVIDOIRS DE PAPIER DE MASQUAGE

- Masking Machine - Fahrbarer Papierständer

040663
75 x 113 cm - 10 kg
108 x 14 x 27 cm

x 4
rouleaux de papier
- Papierständer
- Paper roll
30 & 45 cm,
Ø 75 mm

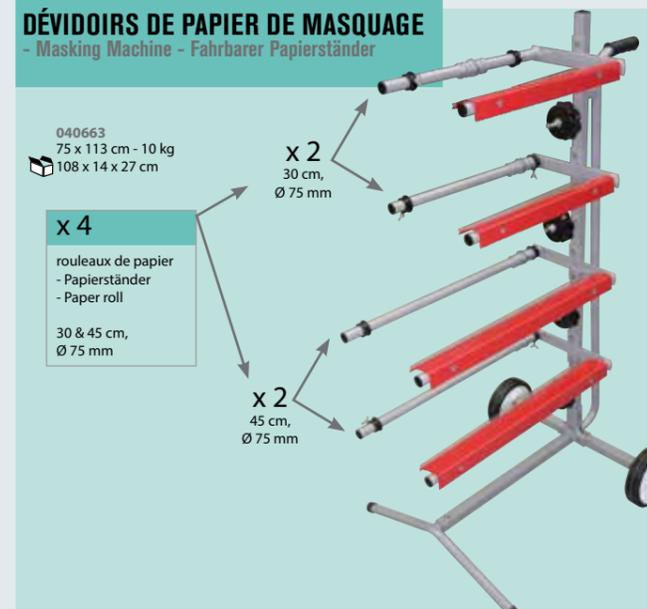

039803
67 x 91 cm - 11,2 kg
92 x 15 x 32 cm

x 2
rouleaux de papier
- Papierständer
- Paper roll
44 cm, Ø 75 mm

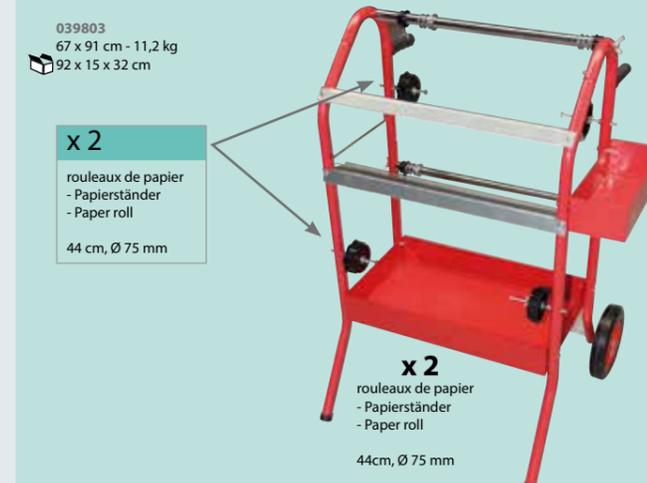

x 2
rouleaux de papier
- Papierständer
- Paper roll
44cm, Ø 75 mm

COUVERTURE ANTI-CHALEUR - Heat cover - Hitzeschutzdecke - Manta anti-calor - Protecção anti-aquecimento

NEW 2016

- PROTEC 550: 550°C/1000°F - Class M0, 2m x 2m - 580 g/m² 050495
- PROTEC 1200: 1200°C/2200°F - Class M0, 1.75m x 1.5m - 1200 g/m² 050204
- PROTEC 1300: 1300°C/2400°F - Class M0, XL: 2m x 1.8m - 620 g/m² 053595
- PROTEC 1300L: 1300°C/2400°F, XL: 2m x 1.8m - 427 g/m² 060500

JEU DE 2 AIMANTS - Set of 2 magnets - Schweißmagnet

(x2) 052291

LUNETTES DE PROTECTION - Protection goggles - Schutzbrillen

Antiprojection/meulage - Anti-projection/grinding - Anti-proyección/amoladura - Spritzschutz/Schleifen

Soudure chalumeau - Torch welding - Soldadura con soplete - Autogenschweißen

- Shade/IR0 042810
- Shade/IR0 042827
- Shade/IR5 042841
- Shade/IR0 042865
- Shade/IR5 042858

RIDEAU DE SOUDAGE - Welding curtain and frame - Schweißerschutzwand

NEW 2016

- OPTI 215.0 Orange CE - 2 x 2.15 m, EN 25980 - 2015/01 060470
- OPTI 200G Green T9 - 2 x 2 m, EN 25980 - 2015/01 060463

GANTS - Gloves - Handschuhe - Guantes

- EN388:2003 4244
- EN12477:2001 4244XX
- Gants Manutention Anti coupe - Anti-cut handling gloves: EN388:4343 T9: 045897
- Anti coupe haute résistance High resistance anti-cut handling gloves: EN 420 - EN 388:3131 T9: 045910
- Anti coupe haute dextérité High precision anti-cut handling gloves: EN 420 - EN 388:3111 T9: 045903
- T10: 045927
- T10: 045934

VESTE - Jacket - Jacke

- EN ISO 11612:2008 A1+A2-B1-C1-E3-F1
- EN ISO 11611:2007 Class 2-A1 & A2
- IEC 61482-2:2009 Class 1-4kA
- EN 1149-5:2008
- EN 14404:2004 +A1:2010 type 2

98% cotton, 2% antistatic

S (40/42) 046313
M (44/46) 046320
L (48/50) 046337
XL (52/54) 046344
XXL (56/58) 046351

PANTALON - Trousers - Hose

98% cotton, 2% antistatic

S (40/42) 046313
M (44/46) 046320
L (48/50) 046337
XL (52/54) 046344
XXL (56/58) 046351

TABLIER CUIR MULTI-USAGE - Multi-use leather apron - Delantal de cuero multi-uso - Mehrzweck-Lederschürze

PRO 045217

MANCHETTES DE SOUDEUR - Welding sleeves - Schweißärmel - Mangas protectoras

450mm

045231

CAGOLE TEXTILE DE PROTECTION - Fireproof protection hood - Textil-Schweißerschutzhaube - Máscara de protección

045224

ASPIRATEURS DE FUMÉE - Fume Extraction Systems - Rauchgasabsauggerät

• 230V / 1 ~ / 50 Hz
• 2 x 1000 W
• AUTOMATIC ON/OFF

EVO 2.1

- 230V / 1 ~ / 50 Hz
- 1100 W
- 1200 m³/h max
- arm 3 m
- included
- 85 kg

046474

Breveté - Patented
Welding detection
Automatic ON/OFF
230 V connection

792 mm
347 mm

2.5 m (included)

150 A, 3m, Grip 043251

Automatic ON/OFF 043237
Manual 043244

039889 5m (included) 040656

039872

040649 (included) 046498

046443

UNI 2.0

- 400V / 3 ~ / 50 Hz
- 1100 W
- 1300 m³/h max
- arm 3 m
- no plug
- 100 kg

NEW

046443

046467

BATTERY SUPPORT UNIT (BSU) BATTERY CHARGER



GYSFLASH 30.12 HF	PFC
30 A	12 V
029224	
GYSFLASH 30.24 HF	PFC
30 A	6/12/24V
029231	
GYSFLASH 40.12 FV	PFC
40 A	12 V
029064	
GYSFLASH 50.12 HF	PFC
50 A	12 V
029088	
GYSFLASH 50.24 HF	PFC
50 A	6/12/24V
029095	
GYSFLASH 100.12 HF	PFC
100 A	12 V
029071	



CHARGE DIAG + SHOWROOM CONNECTOR SHOWROOM Ø M6

U₂ = ADJUSTABLE

TECHNOLOGY & ADVANTAGES

- AUTO DETECT
- MICRO-PROCESSOR CONTROL
- PROTECTION for on-board electronics
- 100% C(Ah) < 90%
- 50% of gain of temps + batterie chargée à 100%
- 50% of time saved + batterie 100% charged
- 50% Zeitersparnis + 100% Vollladung
- ahorro de tiempo de 50% + batería cargada a los 100%
- HIGH EFFICIENCY Up to 15% Energy Saving **93%**
- EMC class B
- SULPHATED BATTERIES AUTOMATIC RECOVERY
- FAN LESS TECHNOLOGY
- POWER FACTOR CORRECTION 185V 265V 100m
- EASY MODE

Option 5m 054615

Tablette - Wall support - Halterung 054592

MEMORY SAVER

230V/12V 055018

PROTECTION ANTI-ARC 12V

- Anti-arc protection 12V - Lichtbogenschutz 12V - Protección anti-arco 12V

041318

SAFETY PROTECTION & BATTERY EQUIPMENT





A COMPLETE RANGE

for 200 > 240 V MONO / TRI
50/60 Hz

DÉBOSSÉLAGE - Dent pulling - デントプラー

<p>GYSLOT 2600 page 6</p>	<p>GYSLOT 2700 page 6</p>	<p>GYSLOT 39.02 page 7</p>	<p>GYSLOT PRO 230 page 7</p>
<p>GYSLOT ALU PRO FV page 8</p>	<p>GYSLOT COMBI 230 PRO page 9</p>		

SOUDURE PAR POINT - Spotwelding - スポット溶接

<p>GYSLOT BP.LC-s7 220 V page 33</p>	<p>GYSLOT BP.LCX-s7 220 V page 36</p>	<p>GYSLOT EVOLUTION PTI-s7 220 V page 37</p>
---	--	---

RIVETAGE - Riveting - リベット打ち

GYSPRESS 8t
page 41

CHARGEUR DE BATTERIE - Battery charger - バッテリーチャージャー

GYSFLASH 40.12 FV
page 69

MIG/MAG TRADITIONNEL - Traditional MIG/MAG - ミグマグトラディショナル

<p>M1GYS AUTO page 44</p>	<p>M3GYS AUTO page 45</p>	<p>T1GYS AUTO DV page 44</p>	<p>T3GYS AUTO DV page 45</p>	<p>PROMIG 350 G.DV page 47</p>	<p>PROMIG 350-4S DUO.DV page 47</p>
--------------------------------------	--------------------------------------	---	---	---	--

MIG/MAG INVERTER - ミグマグインバーター

<p>Multi PEARL 200-2 page 46</p>	<p>Multi PEARL 200-4 XL page 46</p>	<p>Multi PEARL 201-4 page 46</p>
---	--	---

MIG/MAG INVERTER PULSÉ - ミグマグパルスインバーター

<p>NEOPULSE 270-T2 page 48</p>	<p>NEOPULSE 300 page 49</p>	<p>NEOPULSE 300-T2 page 49</p>
---	--	---

DÉCOUPAGE PLASMA - Plasma cutting - プラズマカッター

<p>CUTTER 31 FV page 56</p>	<p>CUTTER 40 FV page 56</p>
--	--

INDUCTION - インダクション

GYSINDUCTION AUTO
page 58



GYS Academy

Centre de formation agréé
Training centre dedicated to professionals
Trainingcenter für Profis

Formations agréées
Ref. 52 53 0068153



FR GYS France

BP 4159
53941 Saint-Berthevin
ZI, 134 bd des Loges
Laval
France
Fax : (+33) 2 43 68 35 21

www.gys.fr
E-mail : contact@gys.fr

DE GYS Germany

Professor-Wieler-Straße 11
52070 Aachen
Deutschland
Tel : (+49) 241 / 189-23-710
Fax : (+49) 241 / 189-23-719
www.gys-schweissen.com
E-mail : aachen@gys.fr

GB GYS UK

Unit 3
Great Central Way
Rugby - Warwickshire - CV21 3XH
United Kingdom
Tel : (+44) 1926 338 609
Fax : (+44) 1926 429 764
www.gys-welding.com
E-mail : uk@gys.fr

IT GYS Italia

C.P. 158 - Mestre Centro
30171 Mestre-Venezia
Italia
Tel : (+39) 340 3677916
E-mail : italia@gys.fr

IN GYS India

796/1A-A, Avinashi road
opp to Decathlon
Neelambur, Coimbatore
641062 Tamil Nadu
India
Tel : +91. 88708. 71111
E-mail : s.kumar@gys.fr

CN GYS China

Lot N°15
6666 bd Songze
201706 Qingpu Shanghai
China
Tel : (+86) 6221 4461
Fax : (+86) 5226 0067
www.gys-china.com.cn
E-mail : contact@gys-china.com.cn

CN Bao Zhi Long Electrical Equipment (JV GYS)

Room: 203C
Building: N°1
N°518 Shen Wang Road
Minhang District Shanghai
China
Tel1 : (+86) 52217650
Tel2 : (+86) 52217651
Tel3 : (+86) 52217652
Fax : (+86) 52217653
www.bzl-china.com
E-mail : mz@bzl-china.com

Distributed by

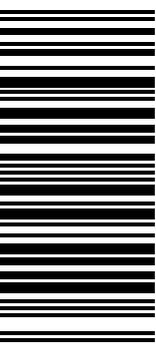

sstarif 095106

Document non contractuel. GYS se réserve le droit de modifier sans préavis les spécifications de ses appareils - Document not contractual.
GYS reserves the right to modify the specifications of the machines without prior notice. Irrtümer und Änderungen vorbehalten.

www.gys.fr