



ELANTRA

Body Repair Manual

INTRODUCTION

This Body Repair Manual provides detailed repair procedures for repair of commonly damaged structural panels on the Hyundai 2007 ELANTRA(HD). To aid in the information of the damaged vehicle, body construction, replacement parts, body dimensions, body sealing locations, corrosion protection, body modification tools, plastic parts and body repair procedures are contained herein.

The repair procedures specify locations where body members may be structurally sectioned. All of the repair procedures have been performed on Hyundai ELANTRA(HD) body shells and that is currently available in most auto body repair shops.

The repair procedures illustrated in this manual were developed to simplify body repair in order to reduce insurance costs, and indirectly, cost of ownership.

The vehicle should not be sectioned in locations other than those illustrated in this repair manual. Furthermore, these repair procedures DO NOT apply to any other vehicle. The individuals performing the work must assume full responsibility for the quality of their workmanship.

We believe this manual to be helpful for Hyundai dealers, and anticipate it to be effectively used for Hyundai vehicle bodies.

For the services of other than collision-damaged body parts of the Hyundai ELANTRA(HD), refer to the ELANTRA(HD) shop manual.

The illustrations and descriptive text in this manual were correct at the time of printing. It is the policy of HYUNDAI MOTOR COMPANY to continuously improve its products. Specifications and procedures are subject to change at any time without notice.

April 2006, Printed in Korea

All rights reserved. No part of this publication may be reproduced, stored in any retrieval system or transmitted in any form or by any means without the prior written permission of Hyundai Motor Company.

CONTENTS

GENERAL INFORMATION

GENERAL GUIDE LINES AND PRECAUTIONS	GI-2
SRS AIR-BAG	GI-3
ELECTRONIC PARTS	GI-4
CORROSION PROTECTION AND SEALING	GI-4
SIDE BODY PANELS	GI-4
WELDING	GI-5

BODY CONSTRUCTION

FRONT & REAR BODY	BC-2
SIDE BODY	BC-3

BODY DIMENSIONS

GENERAL	BD-2
MEASUREMENT METHOD	BD-2
FRONT BODY	BD-4
SIDE BODY	BD-6
INTERIOR A	BD-8
INTERIOR B	BD-11
REAR BODY	BD-13
UNDER BODY (PROJECTED DIMENSIONS)	BD-15
UNDER BODY (ACTUAL-MEASUREMENT DIMENSIONS)	BD-18

BODY PANEL REPAIR PROCEDURE

FENDER APRON PANEL ASSEMBLY	BP-2
FRONT SIDE MEMBER(PARTIAL)	BP-7
FRONT PILLAR	BP-11
SIDE SILL (PARTIAL)	BP-19
CENTER PILLAR	BP-22
QUARTER PANEL	BP-31
BACK COMPLETE PANEL ASSEMBLY AND REAR FLOOR SIDE MEMBER	BP-36

BODY SEALING LOCATION

FLOOR	BS-2
UPPER AND SIDE BODY	BS-5
UNDER BODY	BS-8
HOOD	BS-9
TRUNK LID	BS-10

CORROSION PROTECTION

ZINC-PHOSPHATE COAT & CATIONIC ELECTRODEPOSITION PRIMER	CP-2
ANTIVIBRATION PADS-LOCATION & SECTION	CP-3
ATTACHMENT OF ANTIVIBRATION PADS	CP-6
UNDER BODY COAT	CP-7
SIDE BODY	CP-8
CAVITY WAX INJECTION	CP-9
UNDERBODY ANTI-CORROSION AGENT	CP-10

GI

BC

BD

BP

BS

CP

BT

PP

GENERAL INFORMATION

GENERAL GUIDE LINES AND PRECAUTIONS

The Hyundai ELANTRA is a completely new vehicle design. During its development, close attention has been given to safety, stability, weight and corrosion protection. Typical of unit body design, the Hyundai ELANTRA is designed so that the front and rear compartments will absorb much of the collision energy so that the passengers are better protected. During collisions, these front and rear energy absorbing systems may be severely damaged. During repair, these damaged areas must be returned to their original strength and geometry. If this is not properly done, the vehicle will not provide the intended level of protection to its occupants in the event of another collision.

The repairs described in this manual were performed on ELANTRA body shells. In some instances special fixtures were welded in place to support the structure. During the repair of an actual vehicle, the interior would be fully disassembled and standard jack screws or portable braces may be used for temporary support.

During the repair of an accident involved vehicle, the vehicle must first be returned to pre-impact dimensions prior to beginning the sectioning repair procedures. The extent of damage that must be repaired should then be evaluated to determine the appropriate repair procedures. This manual provides locations and procedures where structural sectioning may be employed. It is the responsibility of the repair technician, based upon the extent of damage, to determine which location and procedure is suitable for the particular damaged vehicle.

During the repair of a collision damaged automobile, it is impossible to fully duplicate the methods used in the factory during the vehicle manufacture. Therefore, auto body repair techniques have been developed to provide a repair that has strength properties equivalent to those of the original design and manufacture.

Certain guidelines and precaution are noted as follow.

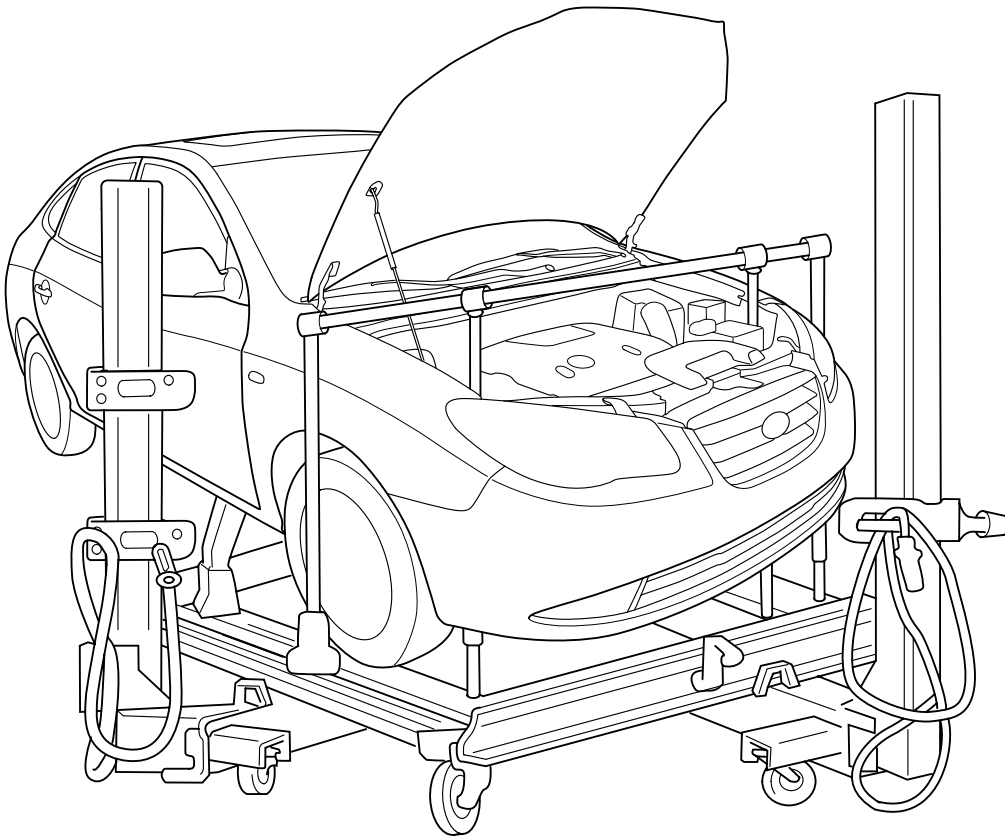

SRS AIR-BAG

SYSTEM COMPONENT

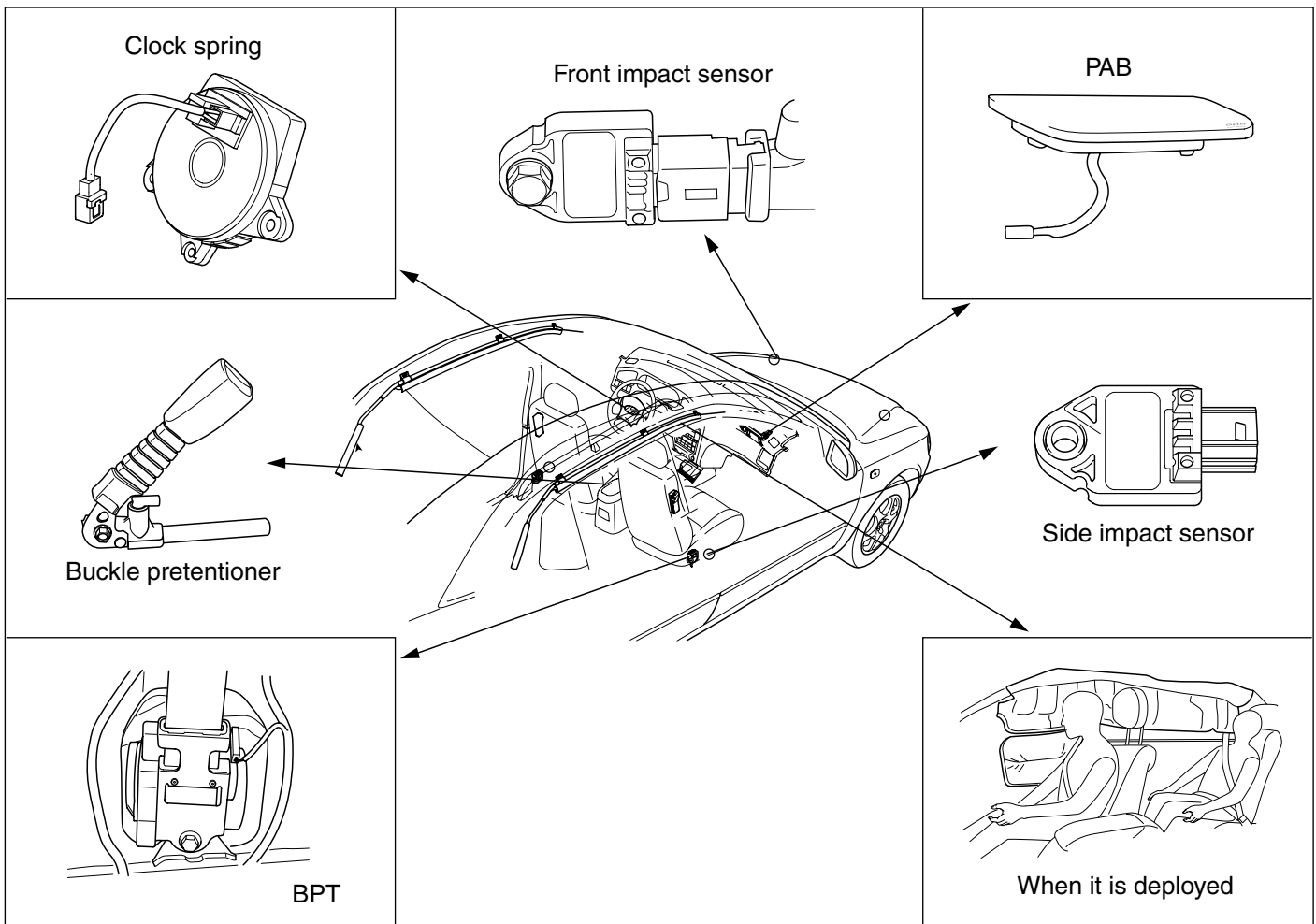

ERKB012A

The Hyundai ELANTRA is equipped with a Supplemental Restraint System AIR-BAG to provide the vehicle's driver and/or the front passenger with additional protection than that offered by the seat-belt system alone, in case of a frontal impact of sufficient severity.

When handling airbag components (removal, installation or inspection, etc.), always follow the directions given in the repair manual for the relevant model to prevent the occurrence of accidents and airbag malfunction.

Also take the following precautions when repairing the body:

1. Work must be started after approximately 30 seconds or longer from the time the ignition switch is turned to the LOCK position and the negative (-) terminal cable is disconnected from the battery. (The airbag system is equipped with a back-up power source so that if work is started within 30 seconds of disconnecting the negative (-) terminal cable of the battery, the airbag may be deployed.)
When the negative(-) terminal cable is disconnected from the battery, memory of the clock and audio systems will be cancelled. So before starting work, make a record of the contents memorized by the audio memory system. Then when work is finished, reset the audio system as before and adjust the clock.
2. When using electric welding, first disconnect the air-bag connectors under the steering column near the MULTI-FUNCTION SWITCH and the passenger's side crash pad before starting work.
3. Store the air-bag modules where the ambient temperature remains below 93°C(200°F), without high humidity and away from electrical noise.
4. WARNING/CAUTION labels are attached to the periphery of the air-bag components.
Refer to the ELANTRA SHOP MANUAL

ELECTRONIC PARTS

Vehicles today include a great many electronic parts and components, and these are in general very susceptible to adverse effects caused by overcurrent, reverse current, electromagnetic waves, high temperature, high humidity impacts, etc. In particular such electronic components can be damaged if there is a large current flow during welding from the body side. Therefore, take the following precautions during body repair to prevent damage to the CONTROL MODULES (ECM, TCM, ABS CM, SRS CM, etc.)

1. Before removing and inspecting the electrical parts or before starting electric welding operations, disconnect the negative (-) terminal cable from the battery.
2. Do not expose the CONTROL MODULES to ambient temperatures above 80°C(176°F).

NOTE

If it is possible the ambient temperatures may reach 80°C(176°F) or more, remove the CONTROL MODULES from the vehicle before starting work.

3. Be careful not to drop the CONTROL MODULES and not to apply physical shocks to them.

CORROSION PROTECTION AND SEALING

Proper corrosion protection and sealing is an important part of any repair. When reviewing these repair procedures, it is important to recognize the need for corrosion restoration to provide for long term strength of the repaired member.

A two part epoxy primer was applied to the metal surfaces during the latter part of the repair. For closed sections, such as front and rear rails, rocker panels and pillars, the primer is applied without applying the metal conditioner and the conversion coating. These steps are omitted to insure that no rinse water is trapped in the closed sections. The primer application is followed by an application of an oil or wax based rust proofing material.

After the corrosion restoration process for the closed sections are completed, then the process can be applied to all exterior sections. For exterior surfaces, both metal conditioner and conversion coating treatments are applied to the exterior surface prior to application of the epoxy primer. The procedure in applying the corrosion restoration process is important order to insure that moisture, due to the water rinsing of the metal conditioner and conversion coating is not inadvertently trapped inside any closed section before the epoxy primer and rust proofing materials have been applied.

Appropriate seam sealers are then applied to all joints. Follow manufacturer's recommendations for the appropriate type of seam sealer to be used at each seam or joint.

SIDE BODY PANELS

The side body panel for ELANTRA is designed and stamped from a single piece of sheet metal in factory as shown in the figure. While the entire side panel is available for service, the partial panels sectioned by several damaged areas are also available. Therefore when repairing side body, refer to "Replacement parts section" of this manual to select and use the appropriate part.

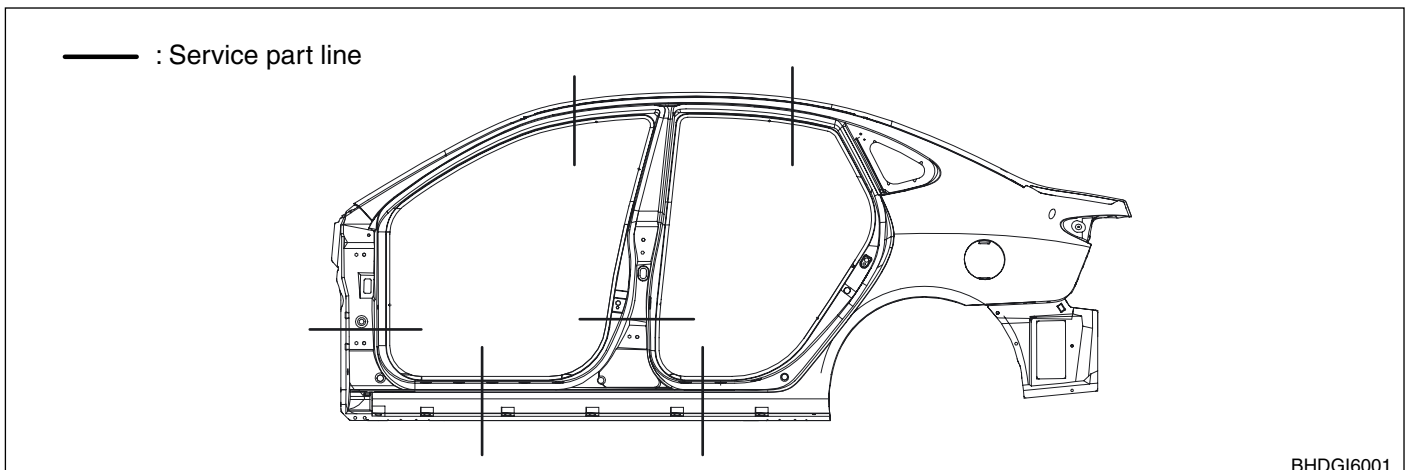

WELDING

All repairs in this manual require the use of a Metal-Inert Gas (MIG) welder, Gas (oxyacetylene) welding must not be used. Both high strength steel and mild steel can be welded using the MIG welder. The I-CAR recommendations for welding should be followed. The shielding gas should be 75% Argon and 25% CO₂.

The recommended welding wire size is 0.23" and the wire should satisfy the American Welding Society standard code AWSER70S-6.

During the repair process, plug welds are used to duplicate original factory spot welds. All plug welds should be done with the MIG welder. An 8 mm (5/16") hole is placed in the top (welding side) sheetmetal.

You then begin welding along the edges and the spiral towards the center (see illustration). This is important so that weld penetration between the two metal pieces takes place along the circumference of the circle.

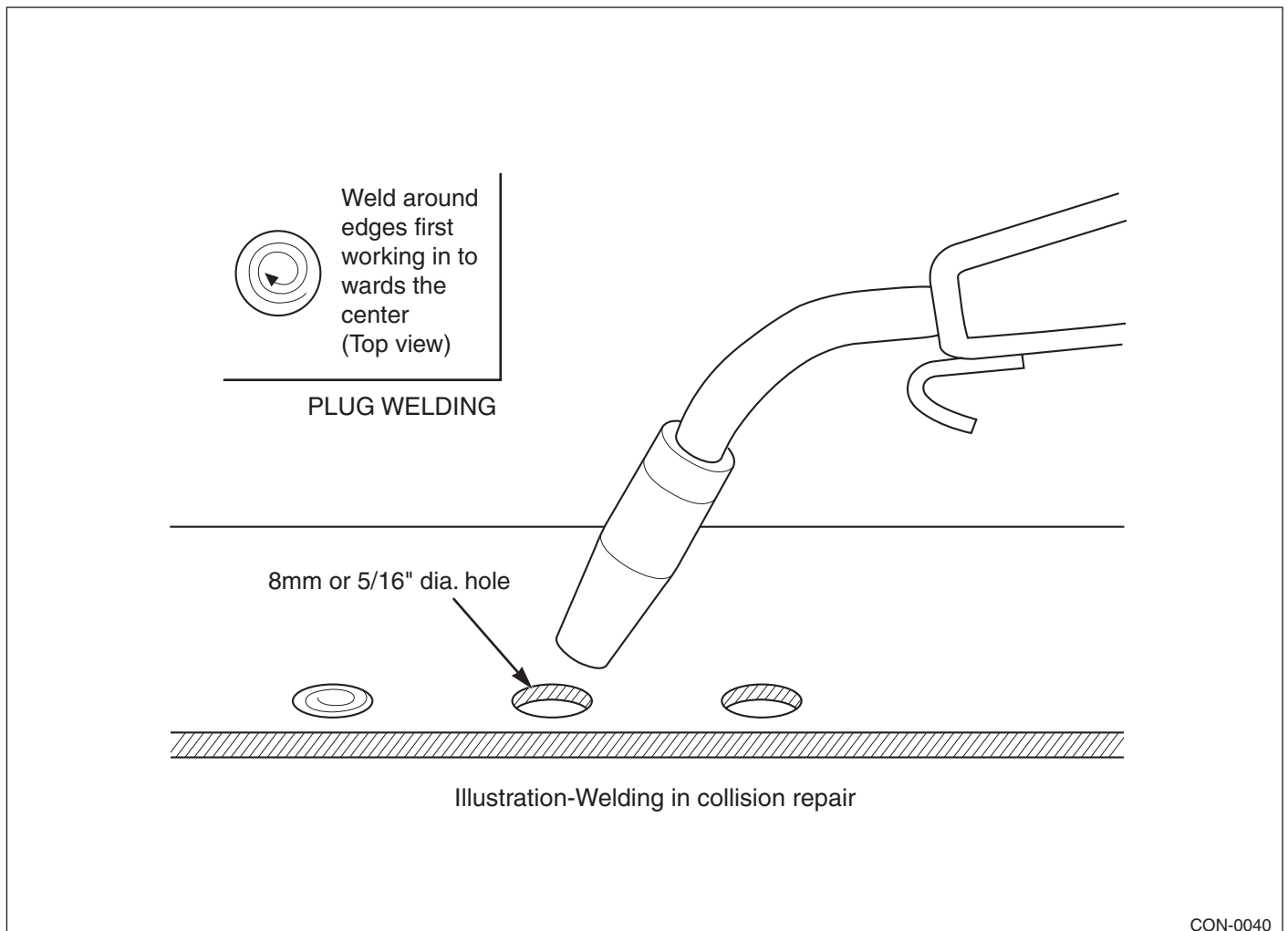

SAFETY FACTORS

Disconnect the negative(-) battery cable before performing any work on the vehicle.

Protect yourself by wearing goggles, earplugs, respirators, gloves, safety shoes, caps, etc. when working on a vehicle.

Safely support the vehicle before any work is done. Block the front or rear wheels if the vehicle is not lifted off of the ground.

Cap or remove the fuel tank when working on the rear section of the car.

Insure proper ventilation of your working area. Some paint and sealant can generate toxic gases when heated. Use an air chisel or saw to remove damaged panels instead of a gas torch.

Observe all local and national safety regulations when performing any work.

Cover interior with heat-resistant cover to insure safety when welding.

Take care when using gas or cutting torches so as not to burn body sealer or interior. Extinguish immediately if they should catch fire.

BODY CONSTRUCTION

FRONT & REAR BODY

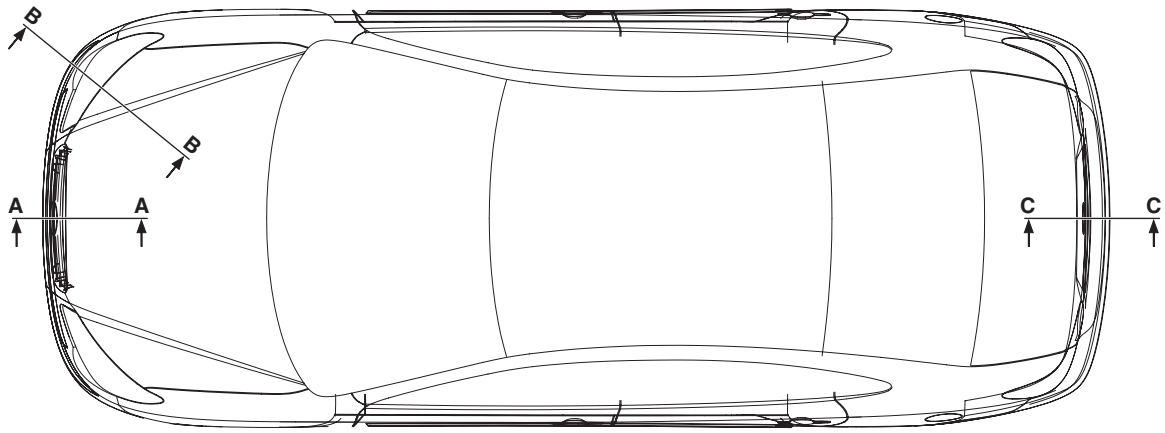

[TOP VIEW]

BHDBC6101

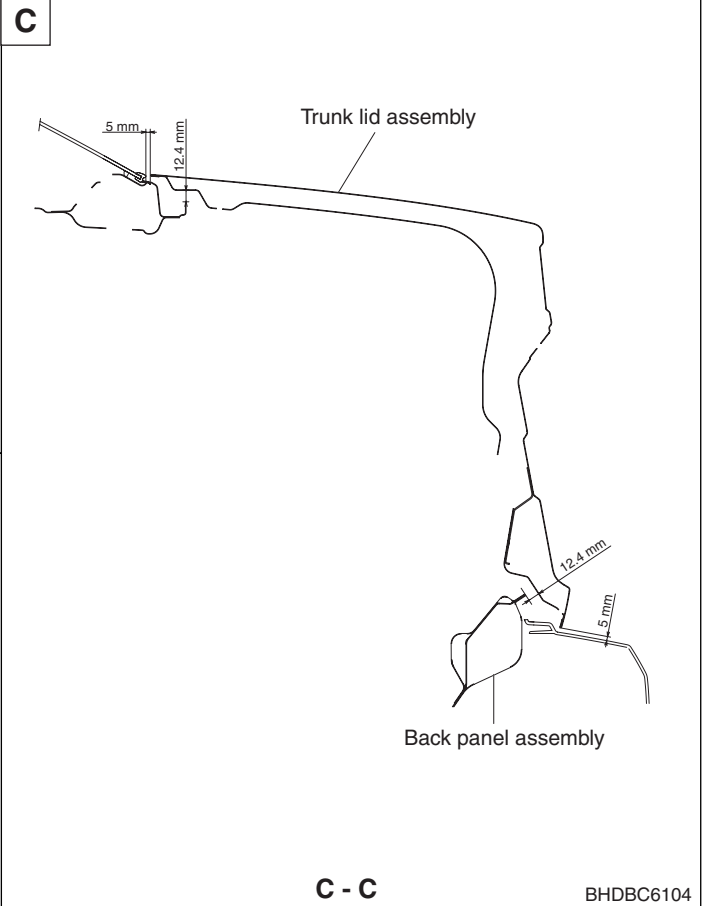
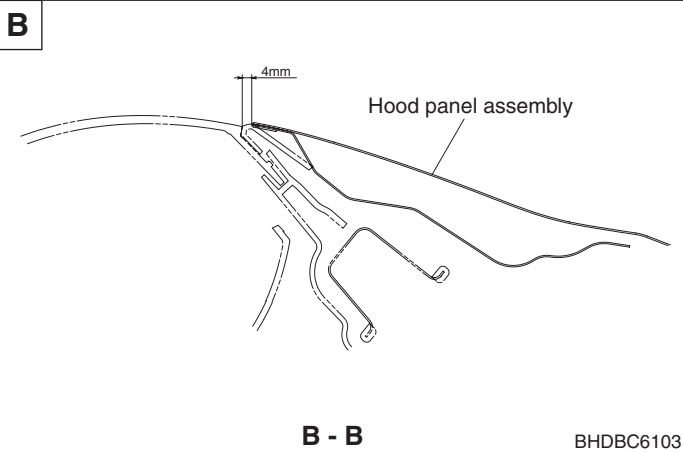
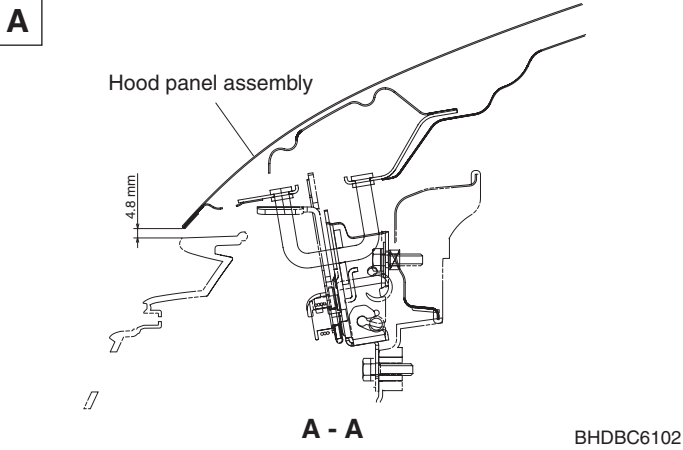

SIDE BODY

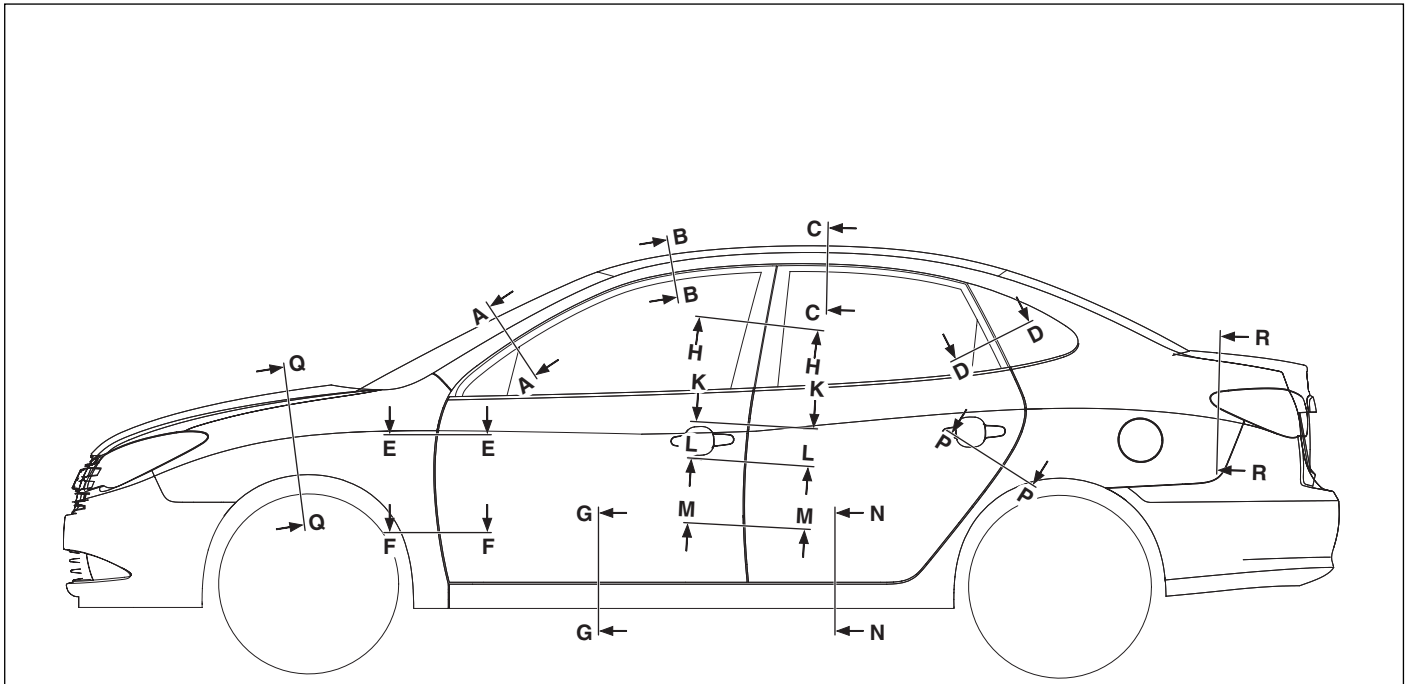

[SIDE VIEW]

BHDBC6201

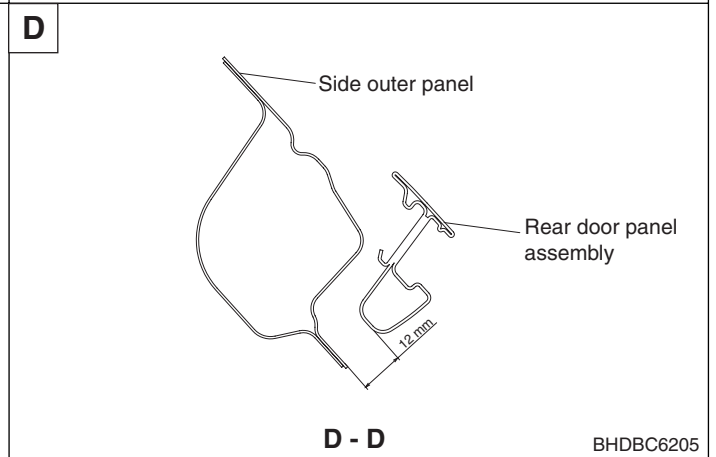
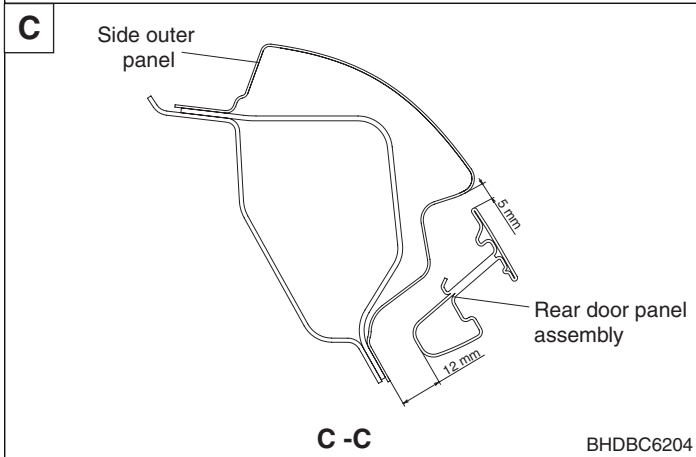
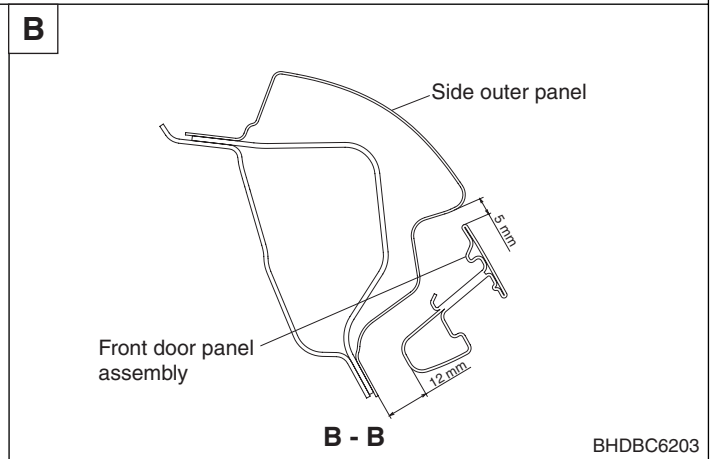
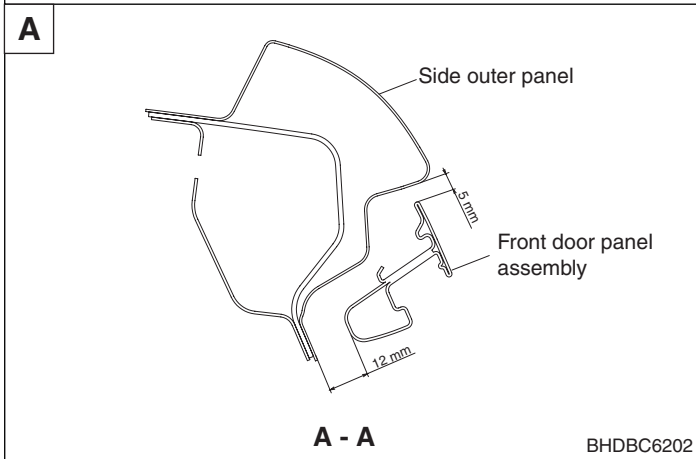

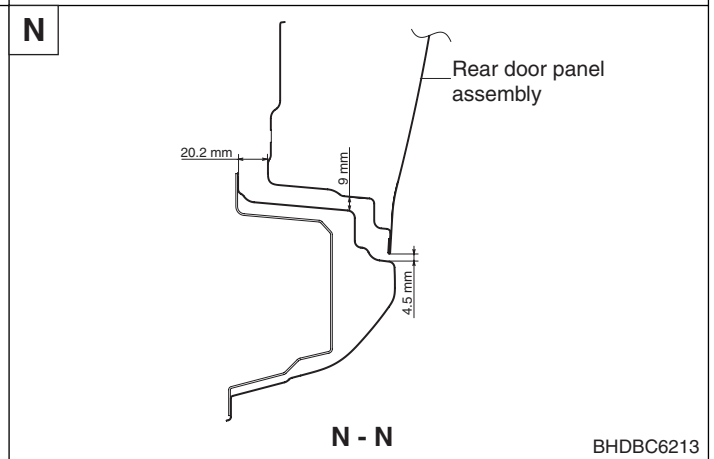
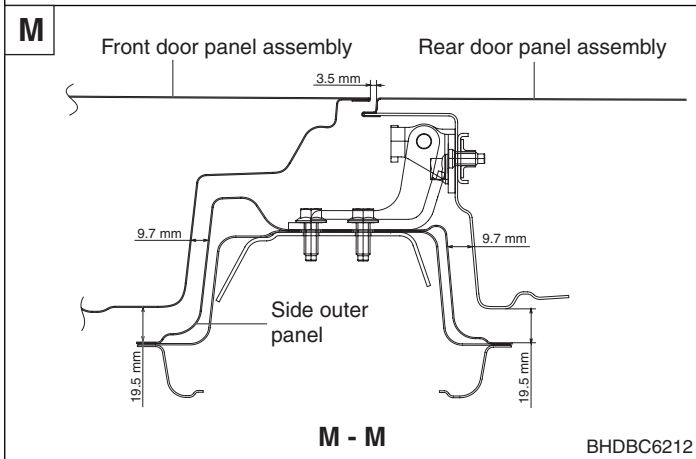
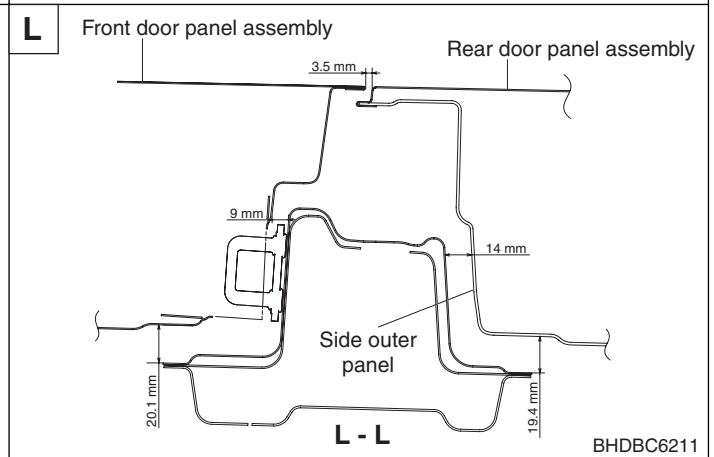
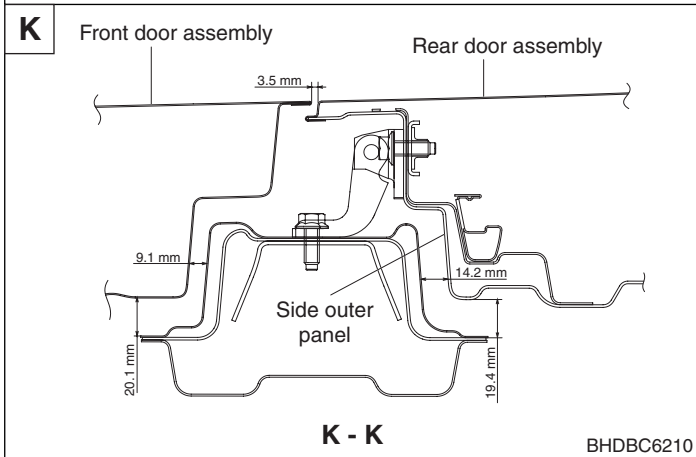
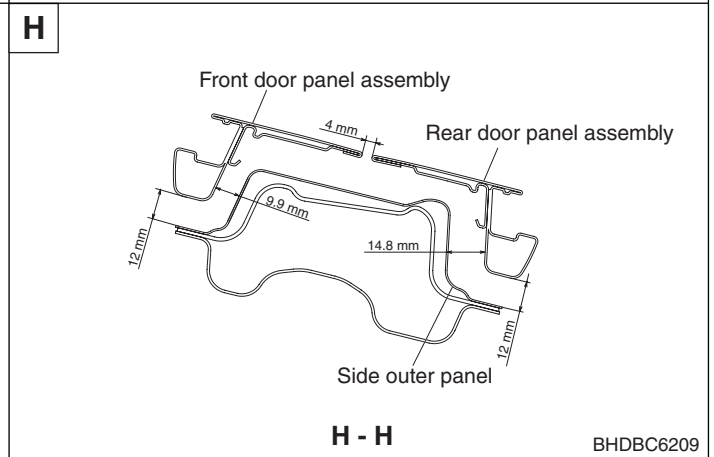
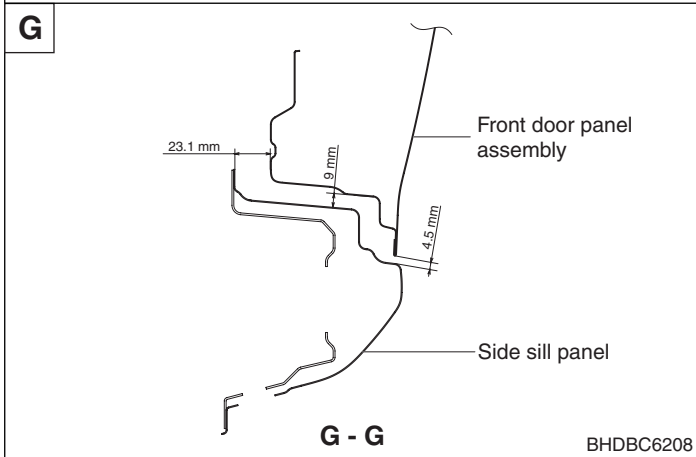
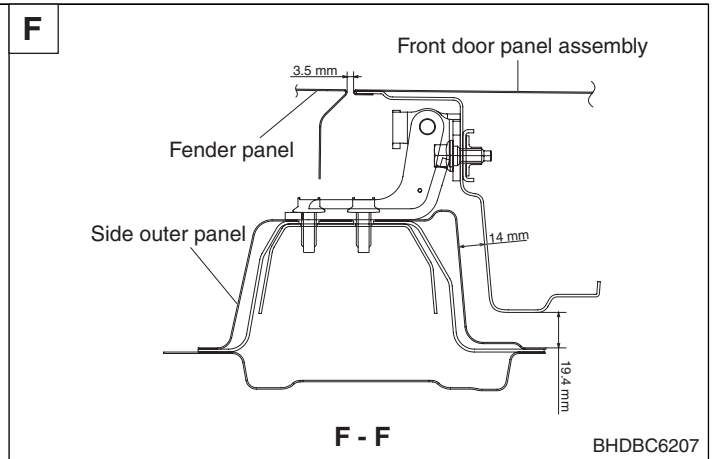
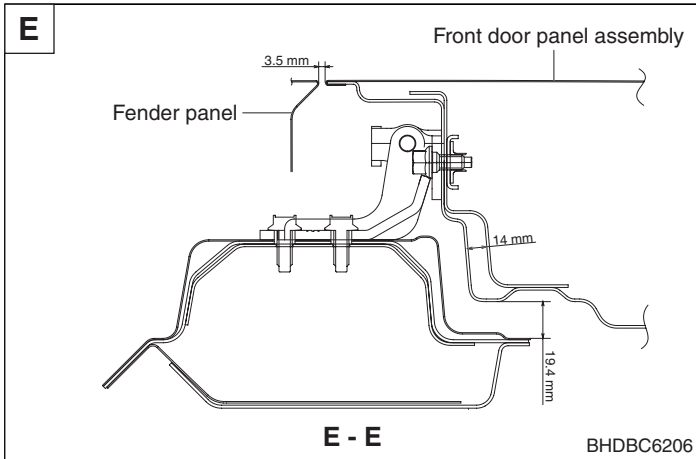

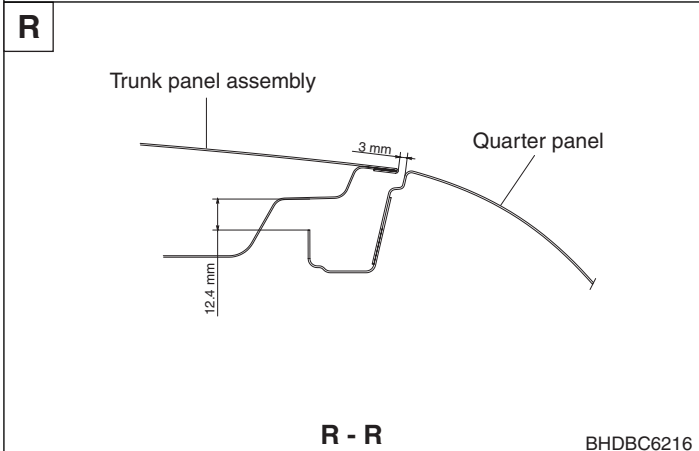
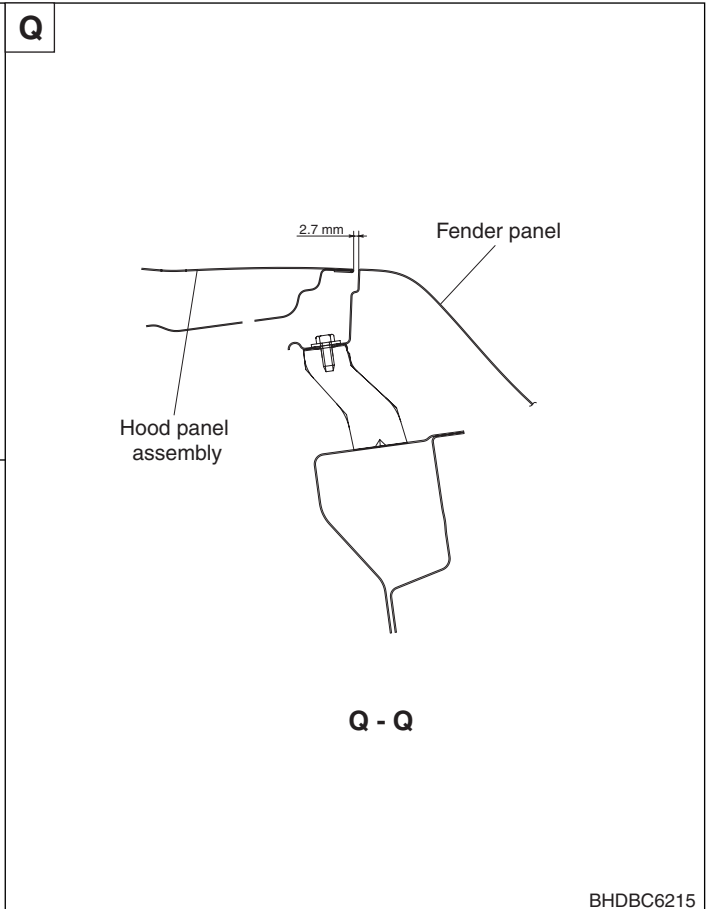
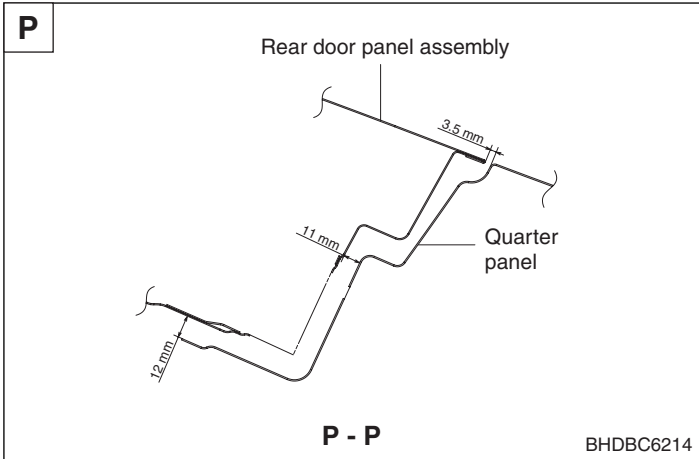

BODY DIMENSIONS

GENERAL

1. Basically, all measurements in this manual are taken with a tracking gauge.
2. When a measuring tape is used, check to be sure there is no elongation, twisting or bending.
3. For measuring dimensions, both projected dimension and actual-measurement dimension are used in this manual.

MEASUREMENT METHOD

PROJECTED DIMENSIONS

1. These are the dimensions measured when the measurement points are projected into the reference plane, and are the reference dimensions used for body alterations.
2. If the length of the tracking gauge probes are adjustable, make the measurement by lengthening one probe by the amount equivalent to the difference in height of the two surfaces.

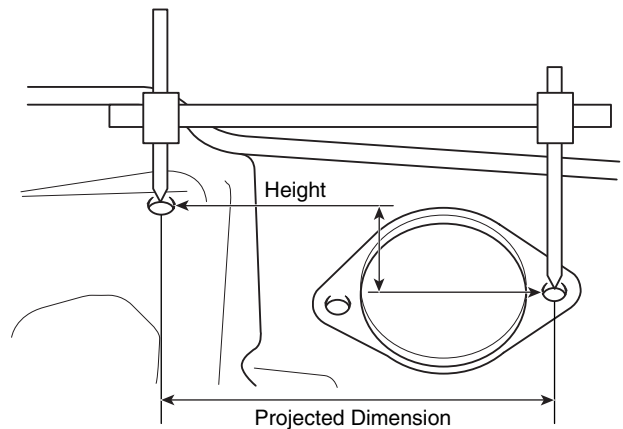

BMCBD6001

ACTUAL-MEASUREMENT DIMENSIONS

1. These dimensions indicate the actual linear distance between measurement points, and are the reference dimensions for use if a tracking gauge is used for measurement.
2. Measure by first adjusting both probes to the same length ($A=A'$)

! CAUTION

Check the probes and gauge itself to make sure there is no free play.

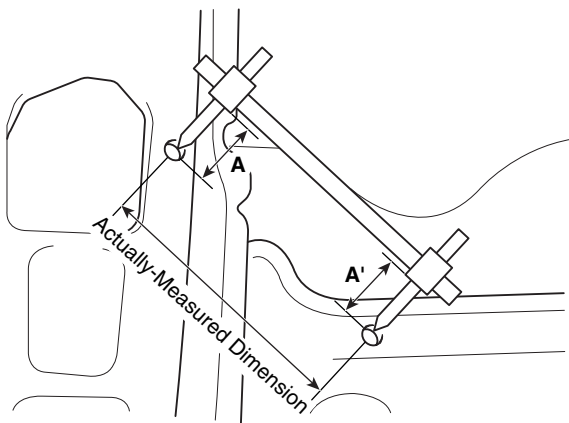

BMCBD6002

MEASUREMENT POINT

1. Measurements should be taken at the hole center.

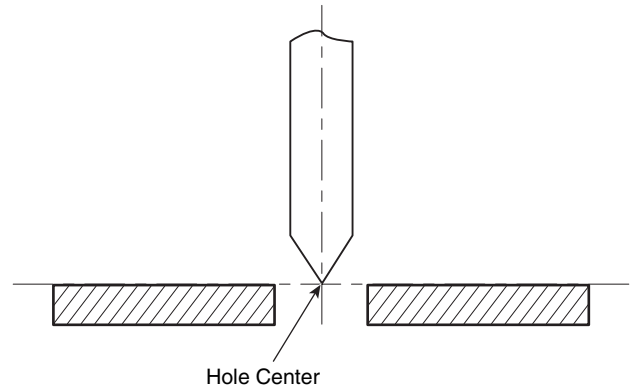

BMCBD6003

FRONT BODY

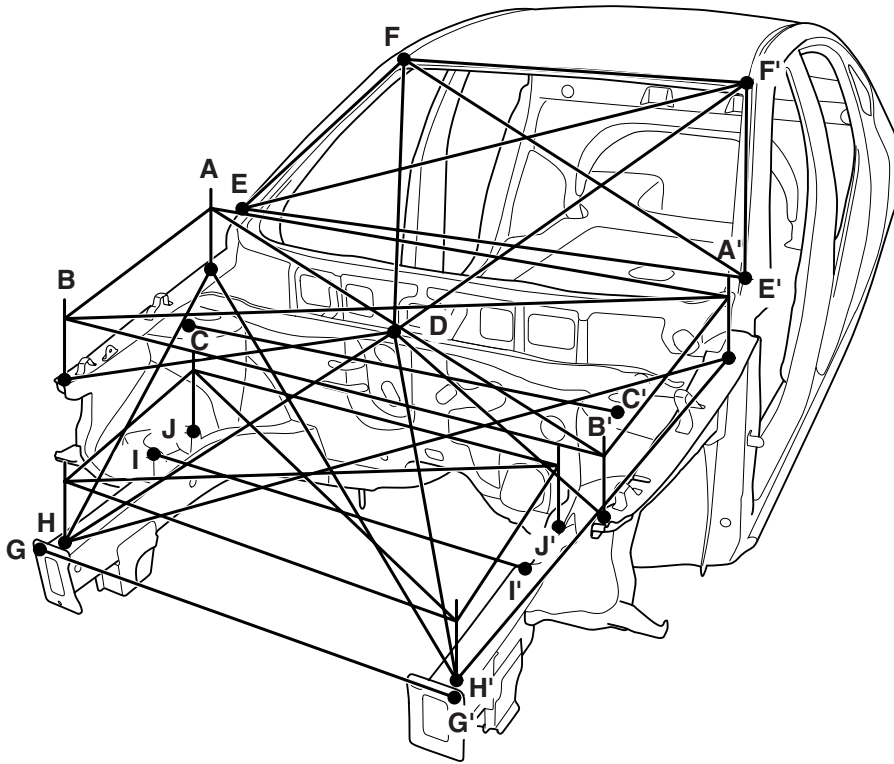

BHDBD6101

* These dimensions indicated in this figure are actual-measurement dimensions.

Point symbol	A-A'	A-B	A-B'	A-H	A-H'	B-B'	B-D	C-C'
Length(mm)	1508	664.3	1592.9	999.7	1594.9	1390	822.7	1181
Point symbol	D-F	D-H	E-E	E-F	E-F	F-F'	G-G'	H-J
Length(mm)	1270.1	924.9	1478.8	765.8	1497.4	1119.7	1074	464
Point symbol	H-J'	H'-J	H'-J'	I-I'	J-J'			
Length(mm)	1140.4	1111.9	563	994.7	987.8			

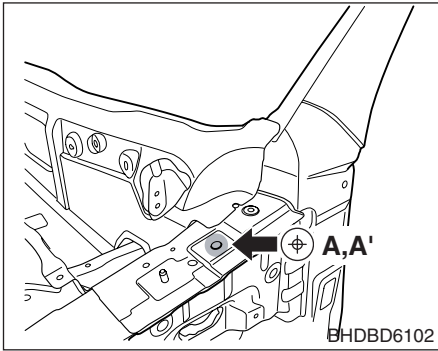

Hood hinge mounting hole (ø9)

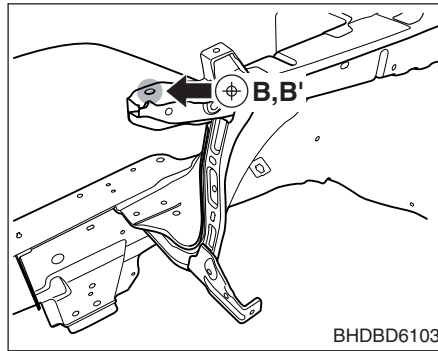

Front end module mounting hole (ø9)

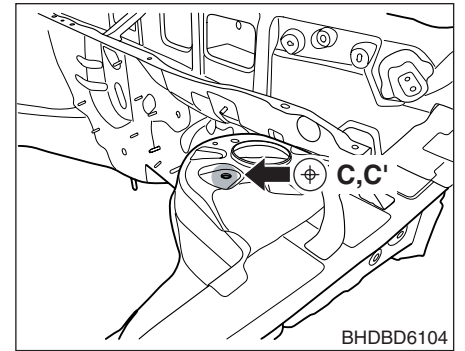

Front suspension mounting hole (ø11)

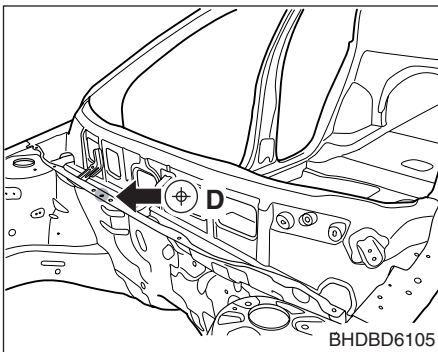

Cowl top cover mounting hole (ø7)

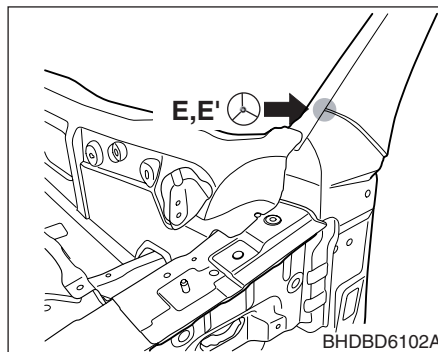

Front pillar corner

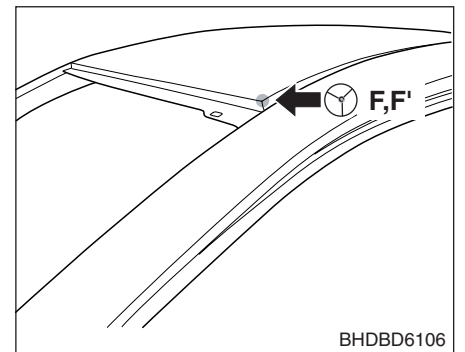

Roof front corner

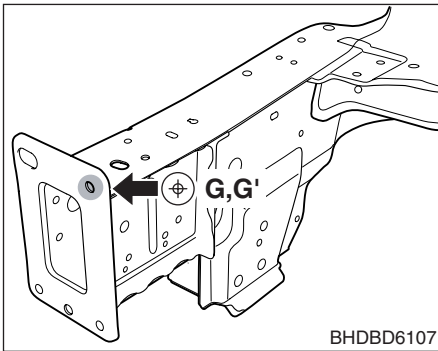

Front bumper mounting hole (ø9)

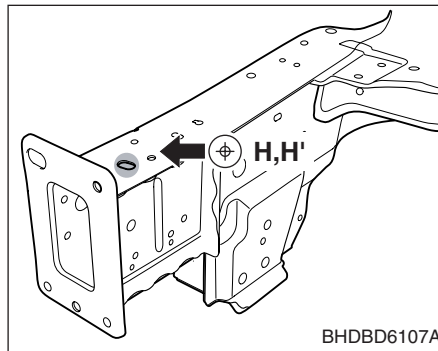

Tooling hole(12X16)

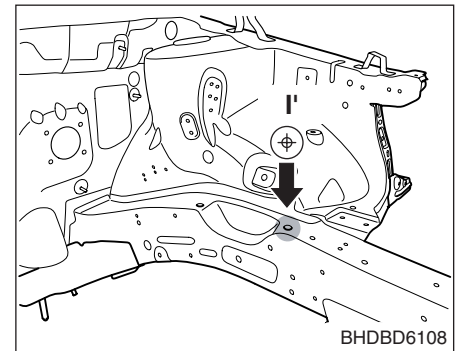

Transmission mounting hole (ø13)

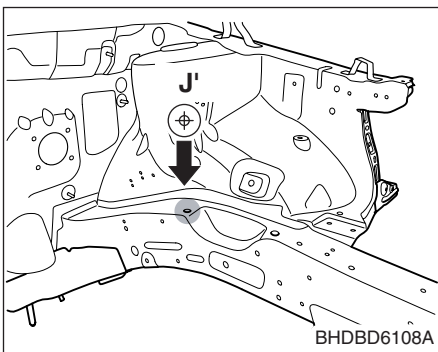

Transmission mounting hole (ø13)

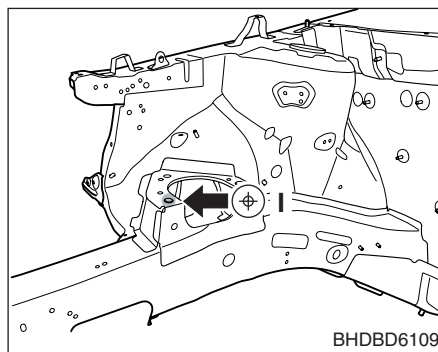

Front engine mounting hole (ø13)

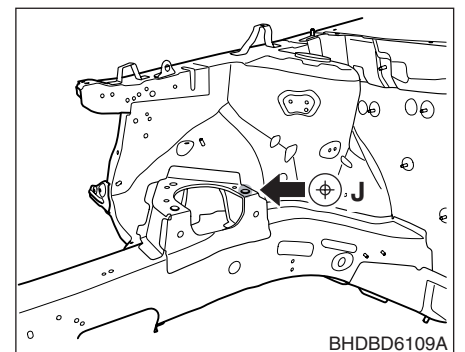

Rear engine mounting hole (ø13)

SIDE BODY

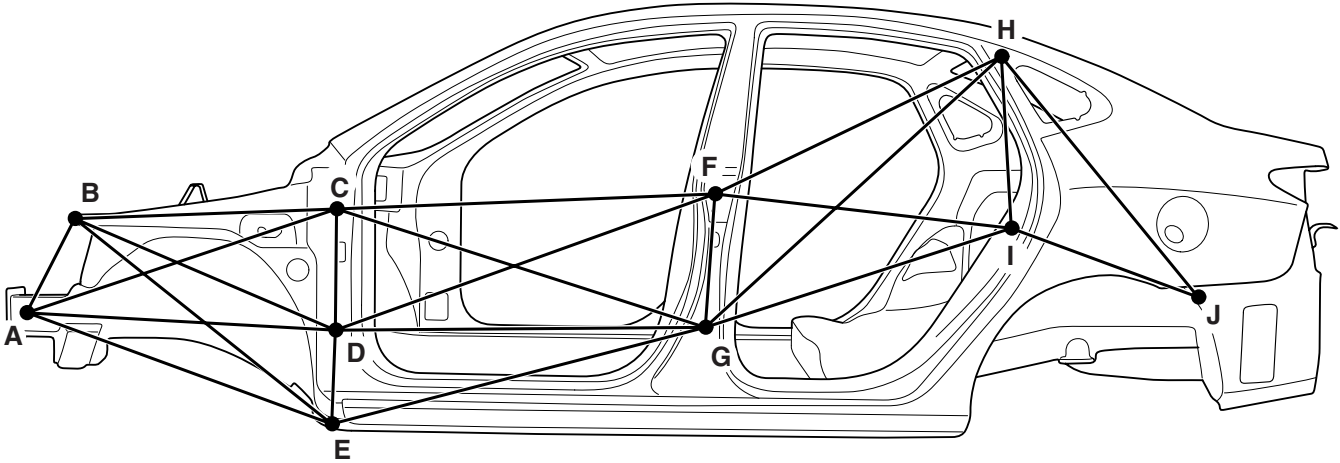

BHDBD6201

* These dimensions indicated in this figure are actual-measurement dimensions.

Point symbol	A-B	A-C	A-D	A-E	B-C	B-D	B-E	C-D
Length(mm)	449.2	1184.2	1136.7	1125	838.2	892.9	998.2	345
Point symbol	C-F	C-G	D-E	D-F	D-G	E-G	F-G	F-H
Length(mm)	1089.8	1111.7	302.8	1160.6	1064.6	1145.8	380.1	953.7
Point symbol	F-I	G-H	G-I	H-I	H-J	I-J		
Length(mm)	867.7	1187.9	931.8	515.3	901.7	565.8		

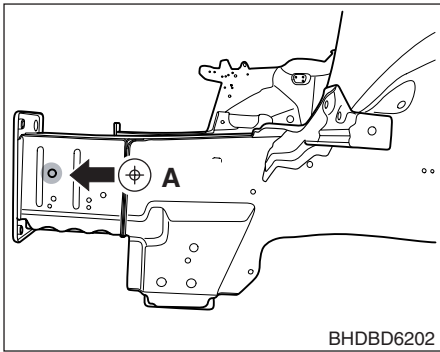

Tooling hole (ø13)

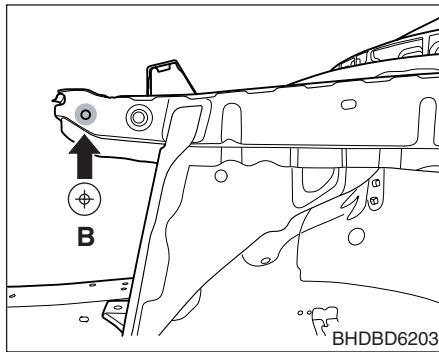

Hood release cable mounting hole (ø7)

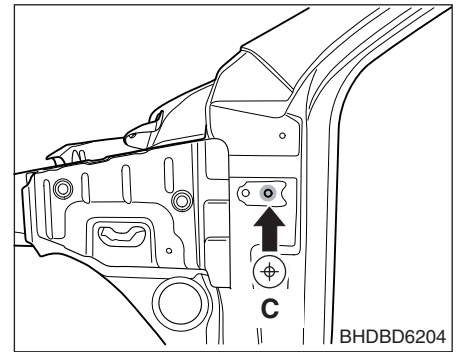

Front door upper hinge mounting hole (ø11)

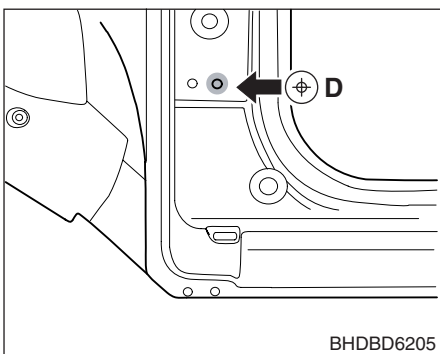

Front door lower hinge mounting hole (ø13)

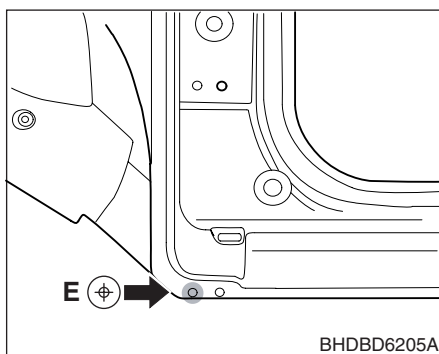

Fender mounting hole (ø12)

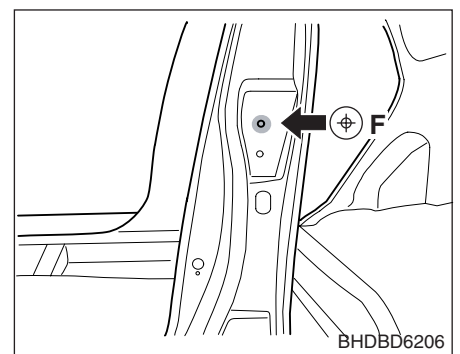

Rear door upper hinge mounting hole (ø13)

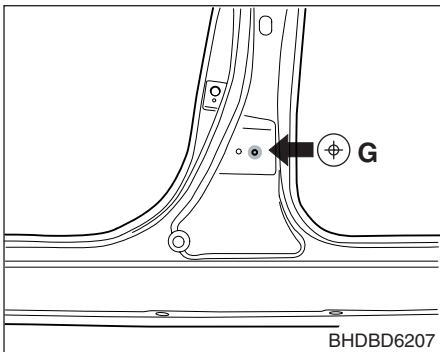

Rear door lower hinge mounting hole (ø13)

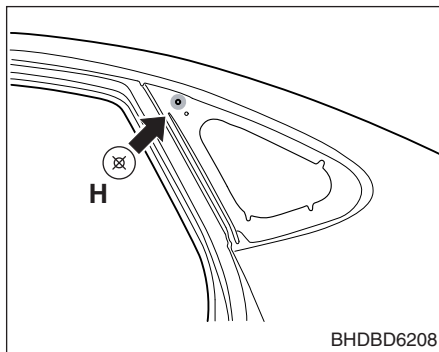

Quarter fixed glass mounting hole (ø7)

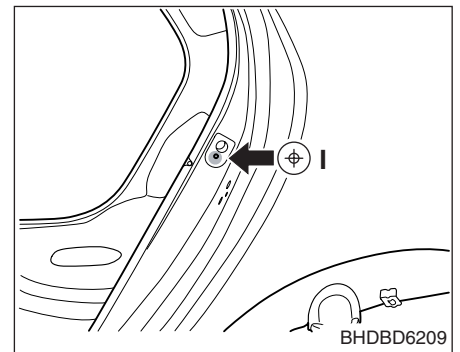

Rear door switch mounting hole (ø10)

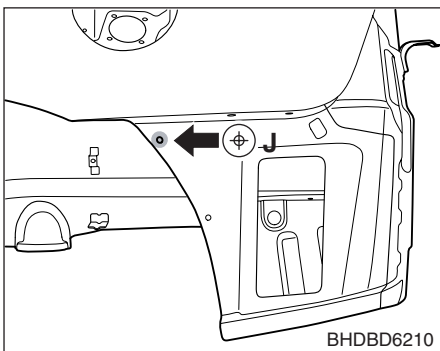

Passage rear wheel guard (ø12)

INTERIOR A

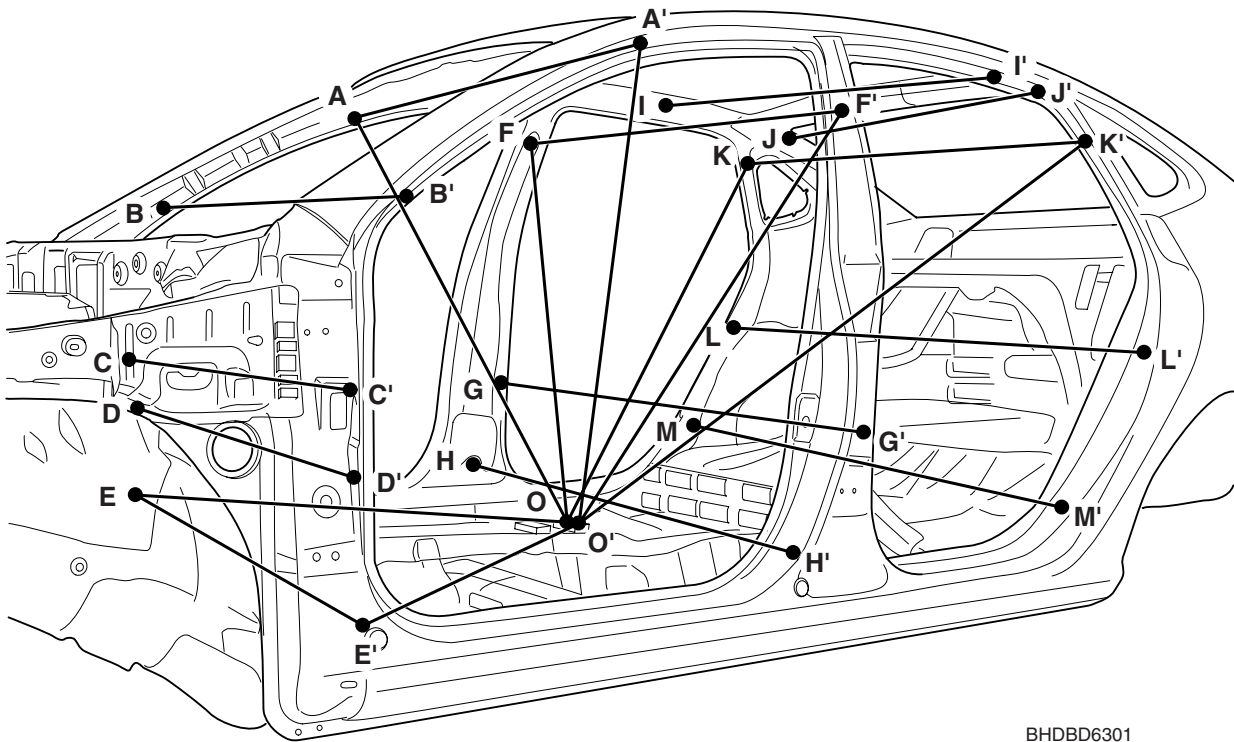

BHDBD6301

* These dimensions indicated in this figure are actual-measurement dimensions.

Point symbol	A-A'	B-B'	C-C'	D-D'	E-E'	F-F'	G-G'	H-H'
Length(mm)	1159.7	1335.5	1405.8	1490.2	1418	1212.7	1490.5	1371
Point symbol	I-I'	J-J'	K-K'	L-L'	M-M'	O-A	O-E	O-F
Length(mm)	1077.2	950	1209.7	1525.2	1425	1137.2	1076.5	1112.9
Point symbol	O-K							
Length(mm)	1146.6							

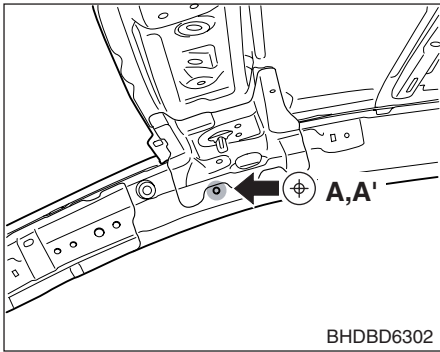

Curtain airbag mounting hole
(ø7)

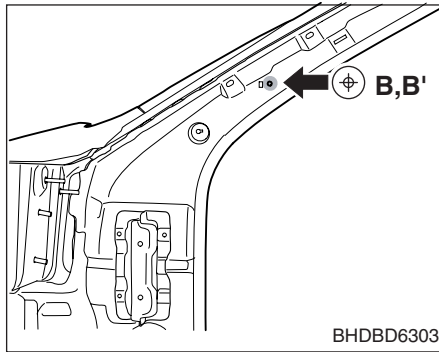

Curtain airbag mounting hole
(ø6.6)

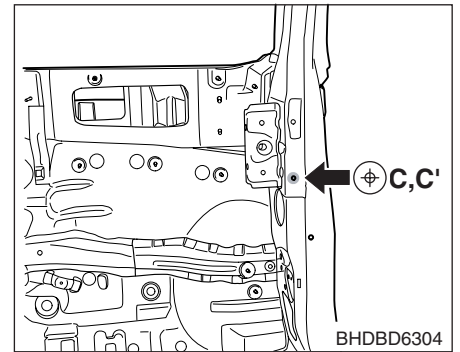

Cowl cross bar mounting hole
(ø9)

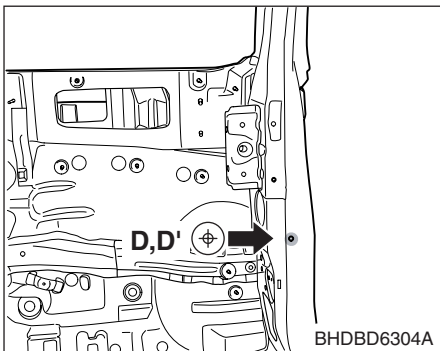

Door checker mounting hole
(ø13)

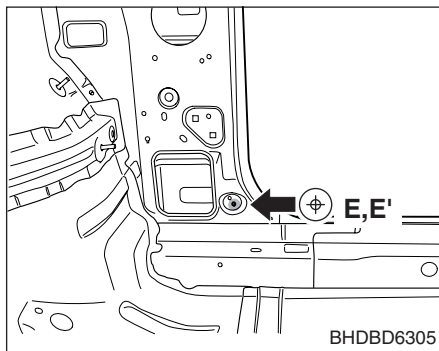

Earth mounting hole
(ø6.6)

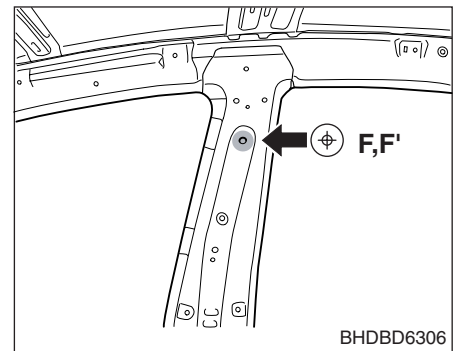

Seat belt height adjust mounting hole
(ø16)

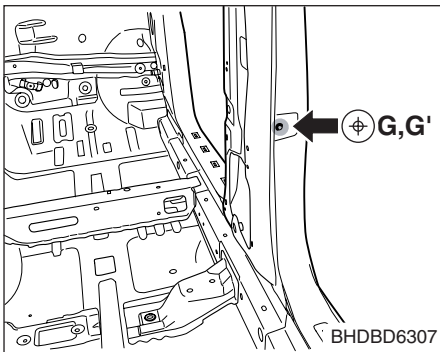

Rear door checker mounting hole
(ø13)

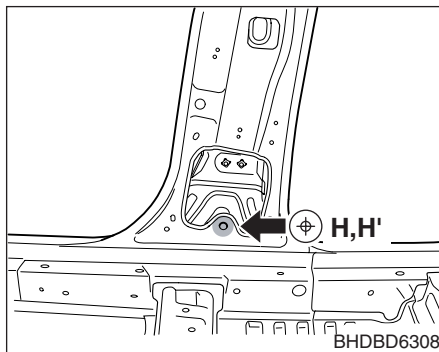

Seat belt retractor mounting hole
(ø12)

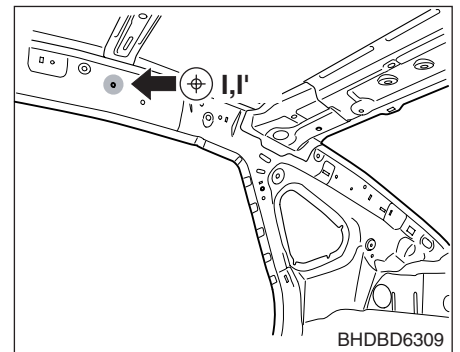

Sun roof set bracket mounting hole
(ø6.6)

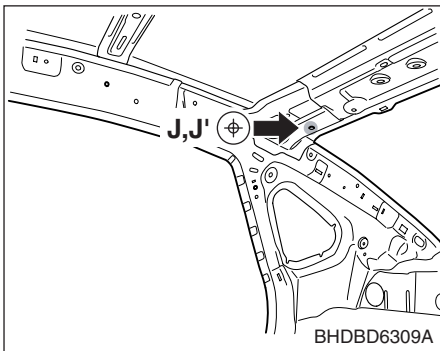

Tooling hole
(ø9)

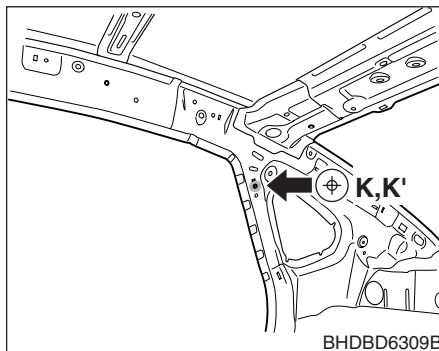

Quarter trim bracket mounting hole
(ø6.6)

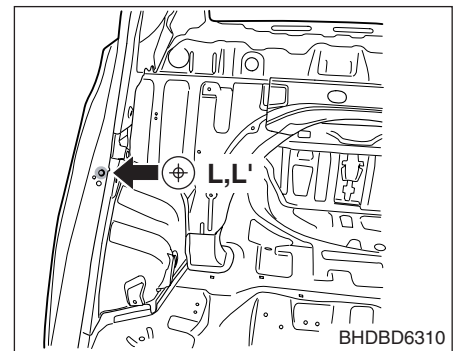

Rear door striker mounting hole
(ø13)

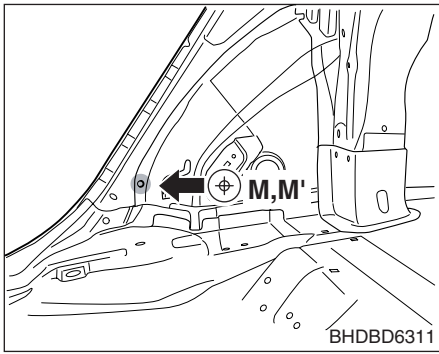

Tooling hole (ø10)

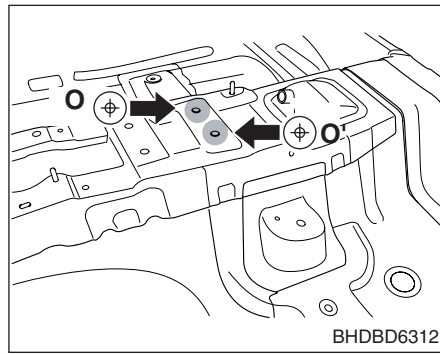

Parking brake lever mounting hole (ø11)

INTERIOR B

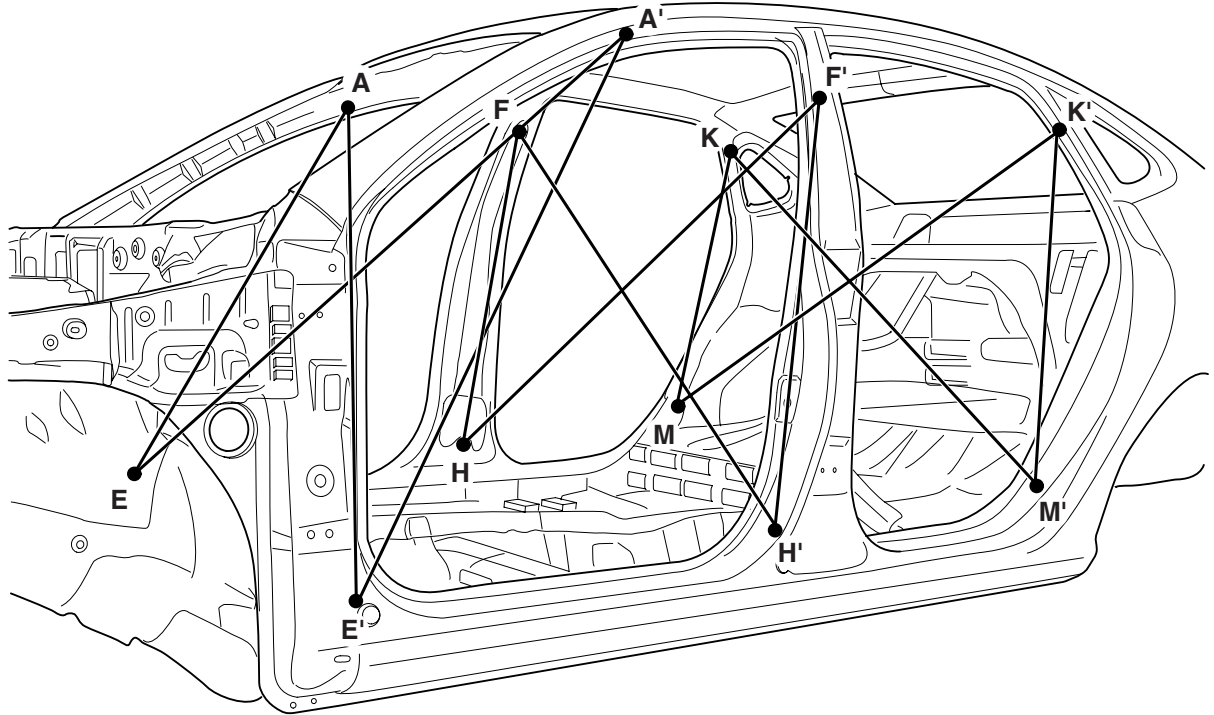

BHDBD6301A

* These dimensions indicated in this figure are actual-measurement dimensions.

Point symbol	A-E	A-E'	F-H	F-H'	K-M	K-M'		
Length(mm)	1098.5	1688.5	866	1553.2	781.6	1528		

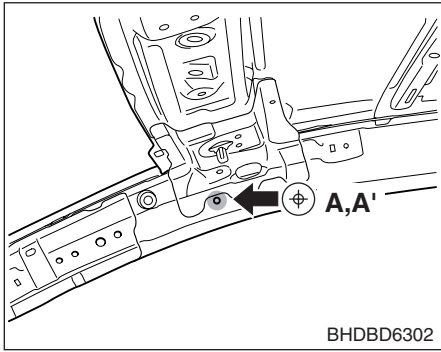

Curtain airbag mounting hole
($\varnothing 7$)

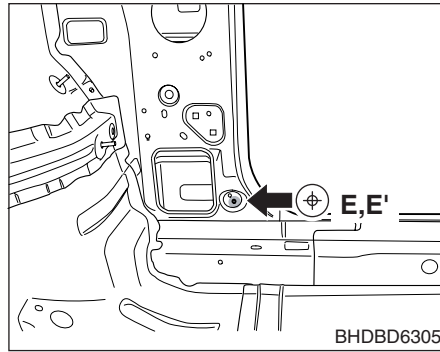

Earth mounting hole
($\varnothing 6.6$)

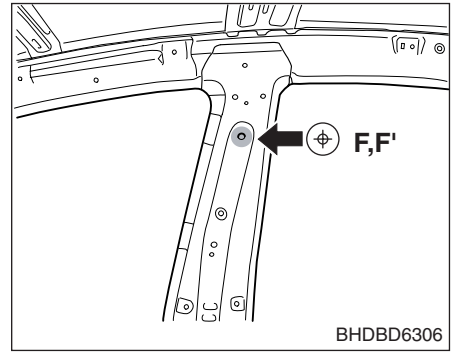

Seat belt height adjust mounting hole
($\varnothing 16$)

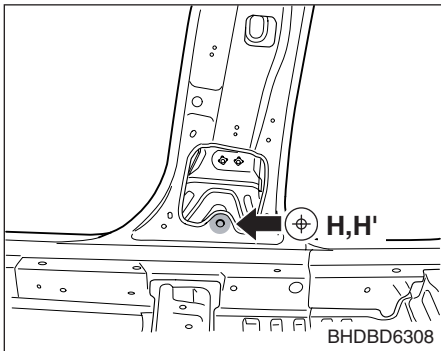

Seat belt retractor mounting hole
($\varnothing 12$)

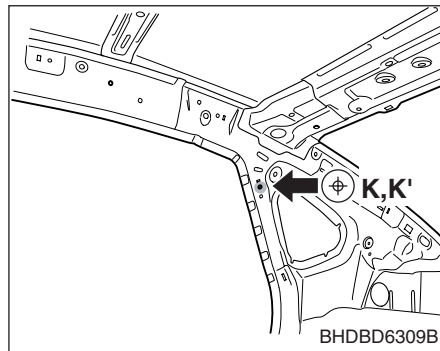

Quarter trim bracket mounting hole
($\varnothing 6.6$)

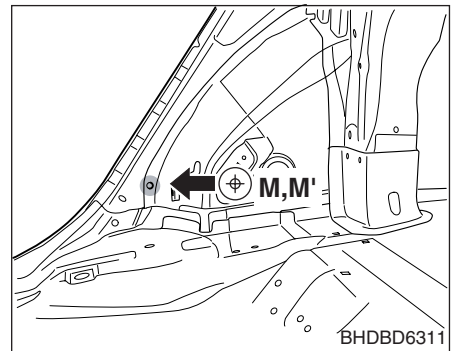

Tooling hole
($\varnothing 10$)

REAR BODY

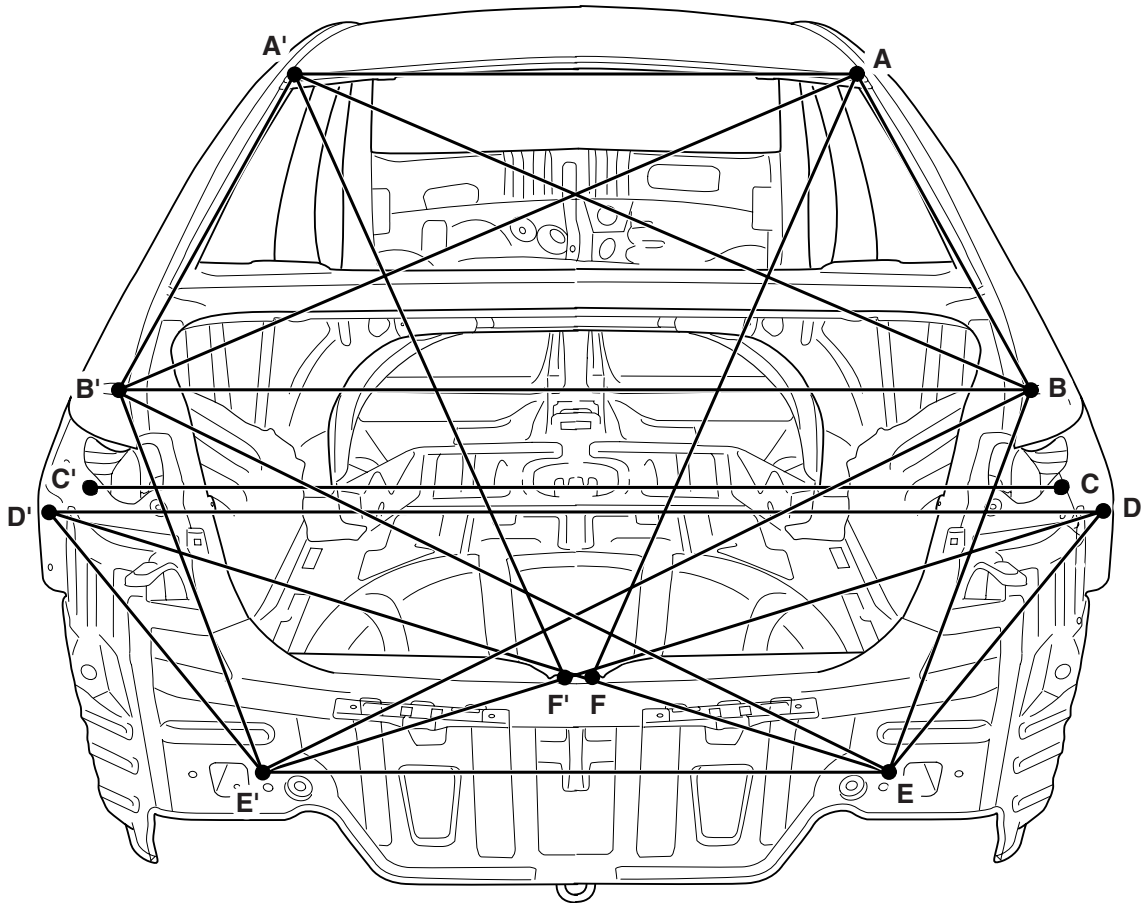

BHDBD6401

* These dimensions indicated in this figure are actual-measurement dimensions.

Point symbol	A-A'	A-B	A-B'	A-F	B-B'	B-E	B-E'	C-C'
Length(mm)	1069.9	1058.4	1527	1364.3	1132.5	578.2	1163.4	1366.1
Point symbol	D-D'	D-E	D-E'	E-E'				
Length(mm)	1520	482.4	1265.2	900				

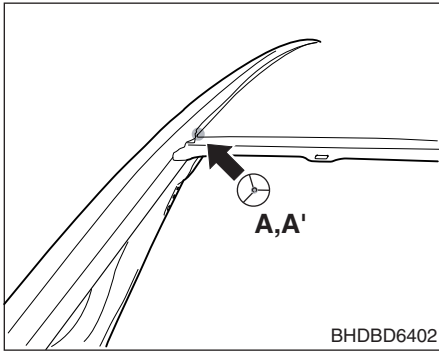

Roof rear corner

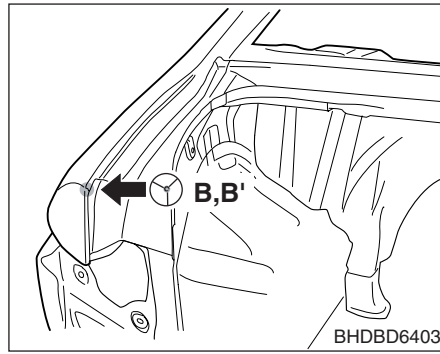

Trunk lid corner

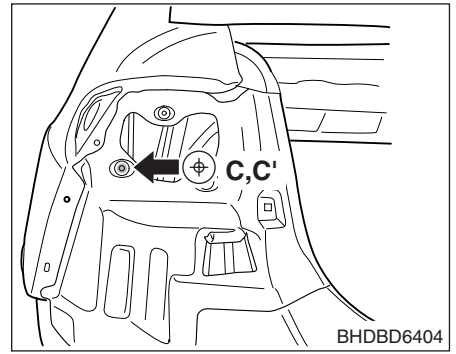

Combination lamp mounting hole
(ø8)

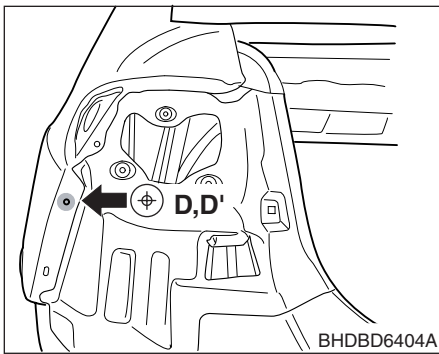

Rear Bumper mounting hole
(ø6)

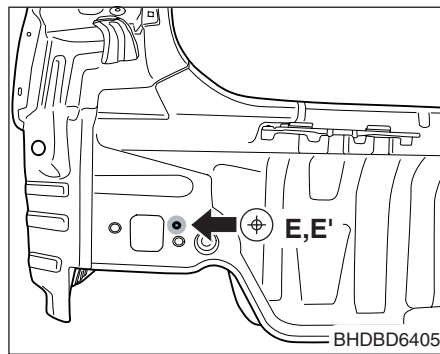

Rear bumper guide hole (10X14)

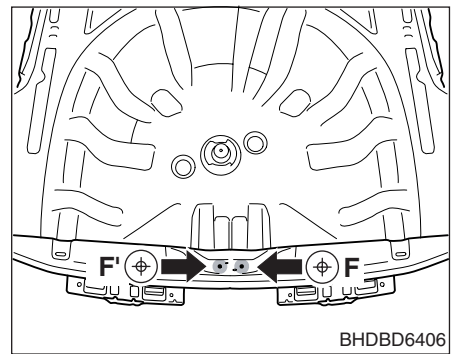

Trunk lid striker mounting hole
(ø6.6)

UNDER BODY(PROJECTED DIMENSIONS)

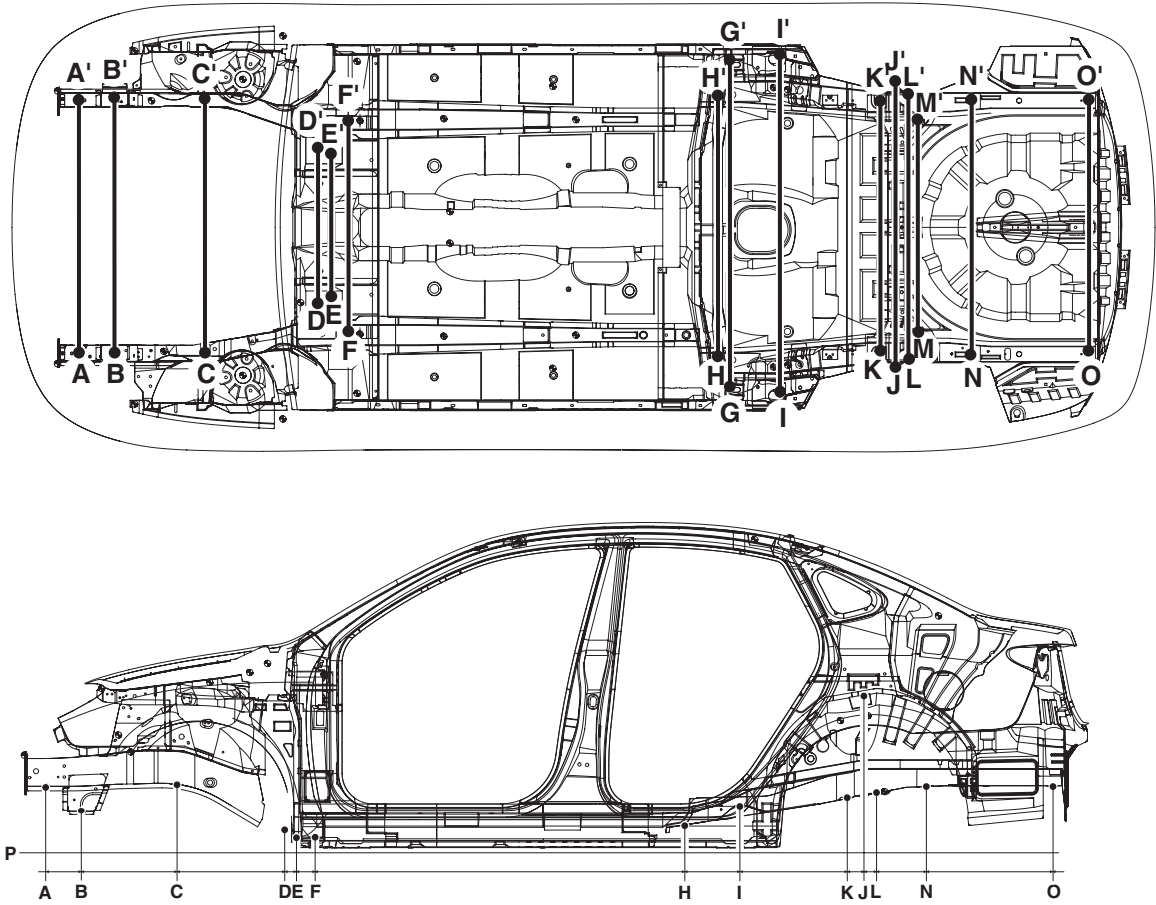

BHDBD6501A

* These dimensions indicated in this figure are projected dimensions.

Point symbol	A-A'	B-B'	C-C'	D-D'	E-E'	F-F'	G-G'	H-H'
Length(mm)	1004	1012	1015	630	590	832	1336	1040
Point symbol	I-I'	J-J'	K-K'	L-L'	M-M'	N-N'	O-O'	P-A
Length(mm)	1328	1122.8	993	1061	839	996	1000	175.6
Point symbol	P-B	P-C	P-D	P-E	P-F	P-H	P-I	P-J
Length(mm)	77.6	184.8	86	9.8	72.6	23.7	99	451.3
Point symbol	P-K	P-L	P-N	P-O	A-B	B-C	C-D	D-E
Length(mm)	130.7	115.4	173.7	178	140	355	445	55
Point symbol	E-F	F-H	H-I	I-K	K-J	J-L	L-N	N-O
Length(mm)	63	1455	220	420	82.7	32.5	166.8	545

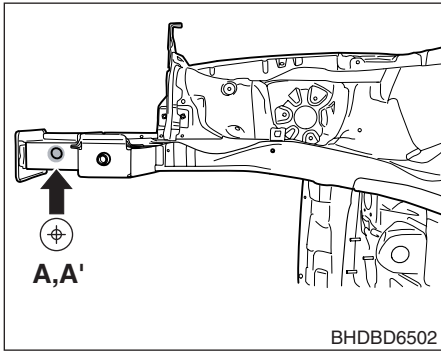

Tooling hole (ø6.6)

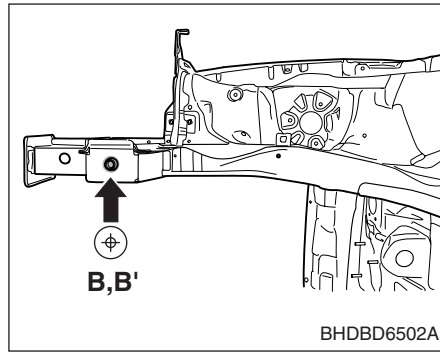

Sub frame mounting hole (ø6.6)

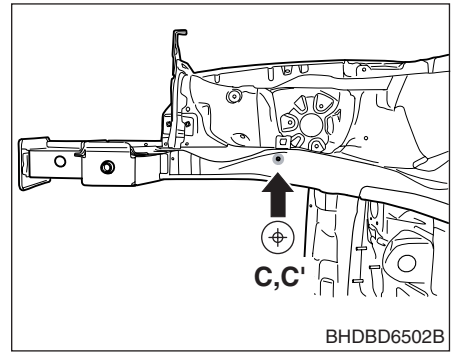

Passage side cover hole (ø10)

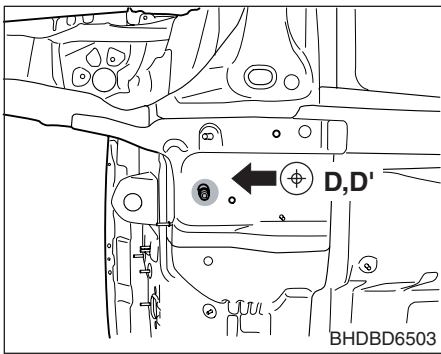

Sub frame mounting bolt

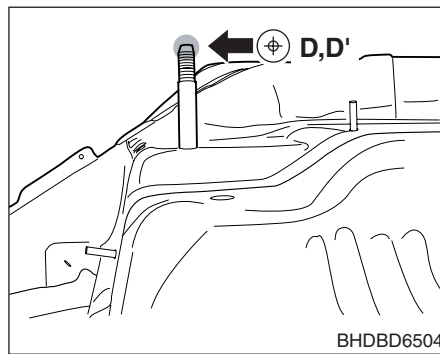

Sub frame mounting bolt

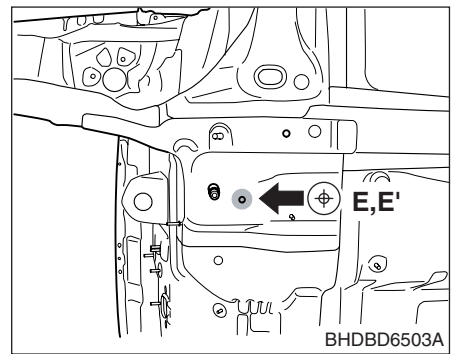

Passage tooling hole (ø10)

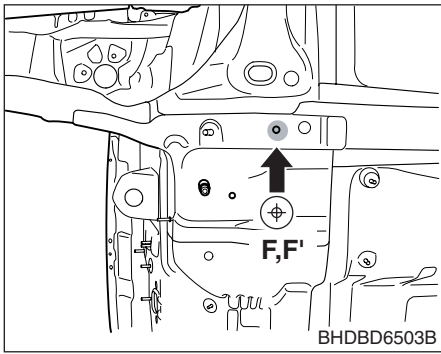

Passage stay mounting hole (ø15)

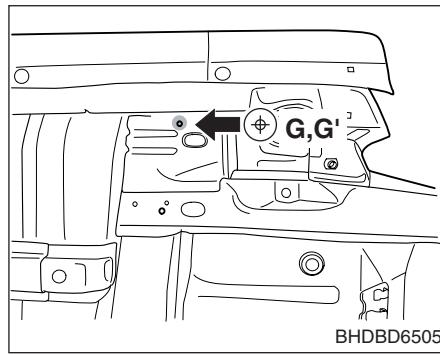

Tooling hole (ø8)

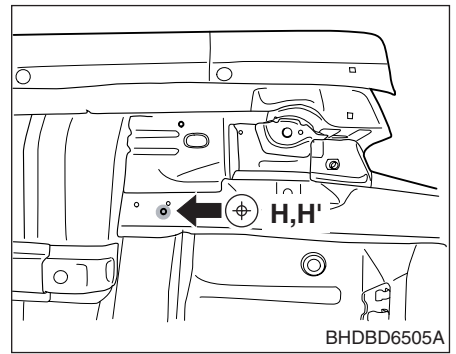

Parking brake cable mounting hole (ø9)

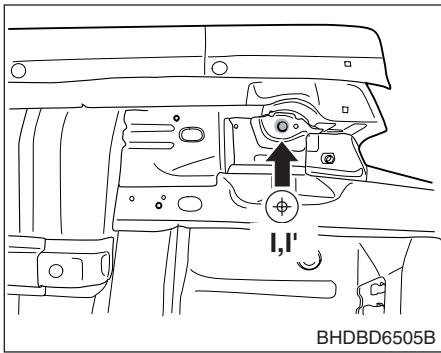

Trailing arm mounting hole (ø28)

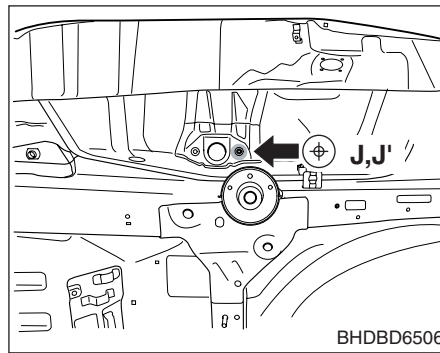

Rear suspension mounting hole (ø21)

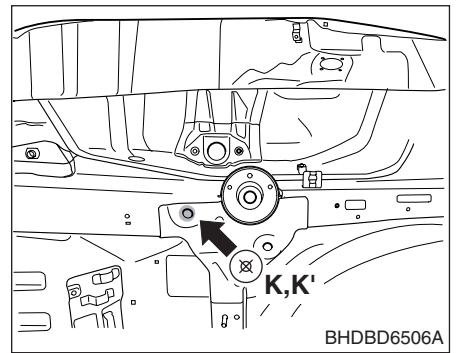

Rear suspension mounting hole (ø18)

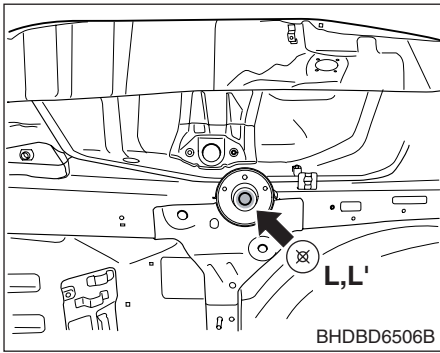

Spring mounting hole
($\varnothing 20$)

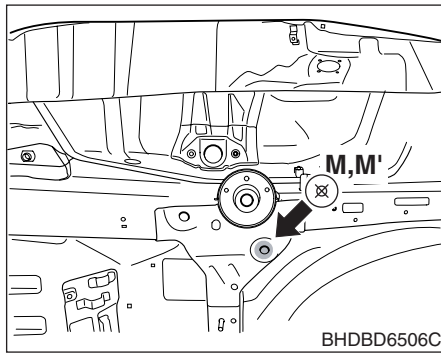

Cross member mounting hole
($\varnothing 18$)

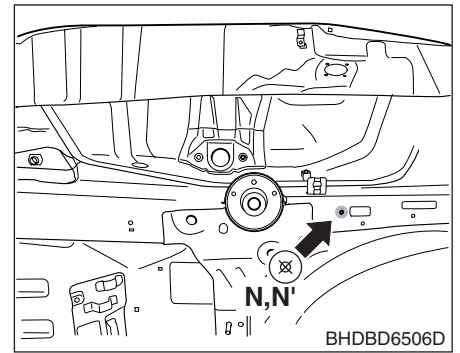

Filler pipe mounting hole
($\varnothing 6.6$)

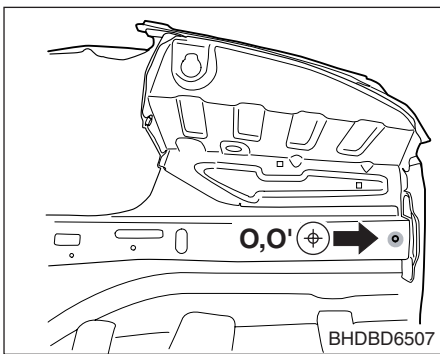

Tooling hole
($\varnothing 10$)

UNDER BODY (ACTUAL-MEASUREMENT DIMENSIONS)

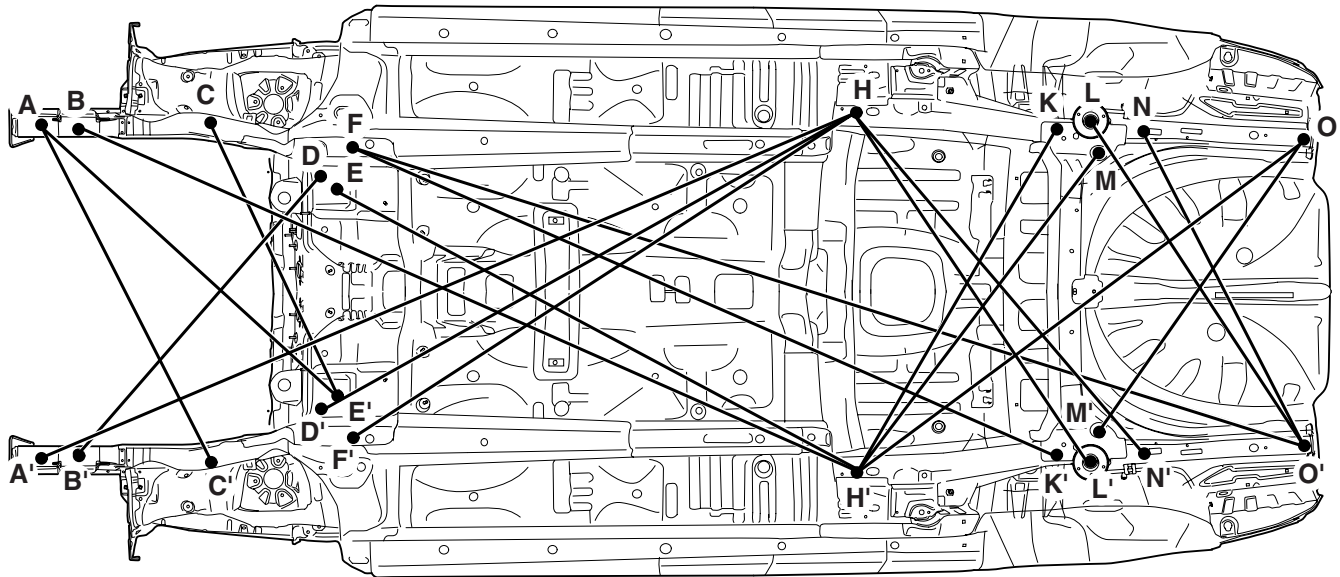

BHDBD6501

* These dimensions indicated in this figure are actual-measurement dimensions.

Point symbol	A-C'	A-E'	A'-H	B-H'	B'-D	C-E'	D'-H	F-K'
Length(mm)	1123	128.6	2717.1	2583.5	1162	2270.9	1784.3	2294.1
Point symbol	F-O'	F'-H	H-L'	H-N'	H'-K	H'-M	H'-O	L-O'
Length(mm)	3072.4	1732.7	1297	1381.6	1205.9	1234.6	1793.4	1254
Point symbol	M'-O	N-O						
Length(mm)	1142	1137.1						

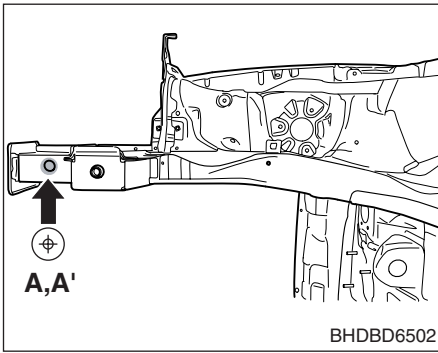

Tooling hole (ϕ6.6)

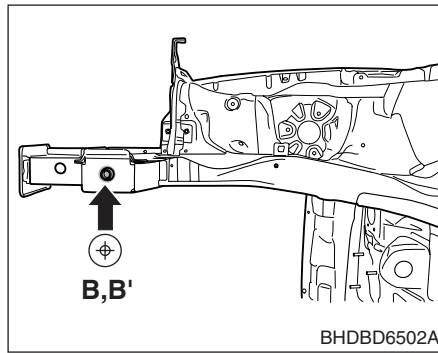

Sub frame mounting hole (ϕ6.6)

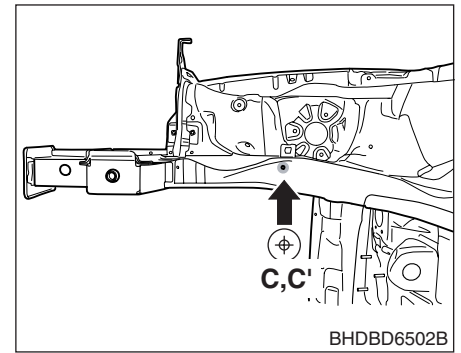

Passage side cover hole (ϕ10)

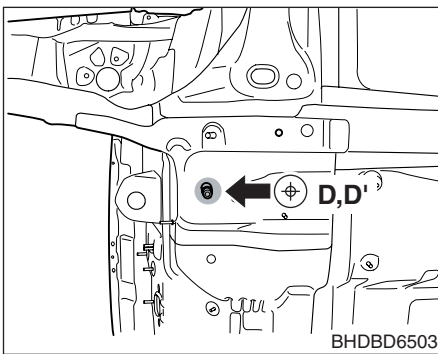

Sub frame mounting bolt

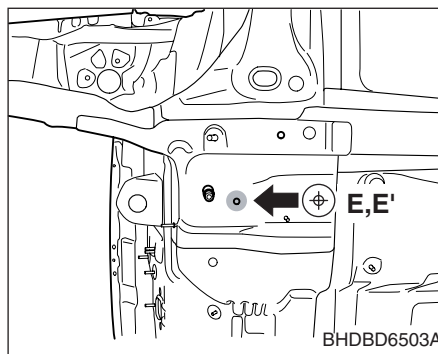

Passage tooling hole (ϕ10)

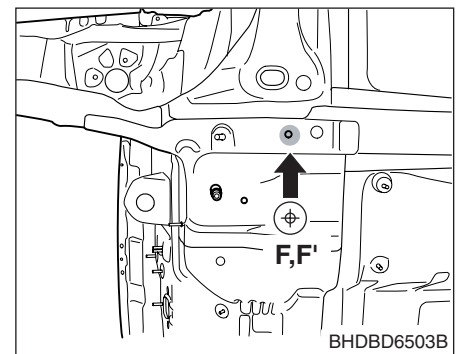

Passage stay mounting hole (ϕ15)

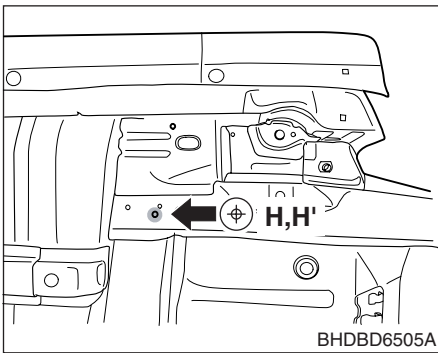

Parking brake cable mounting hole (ϕ9)

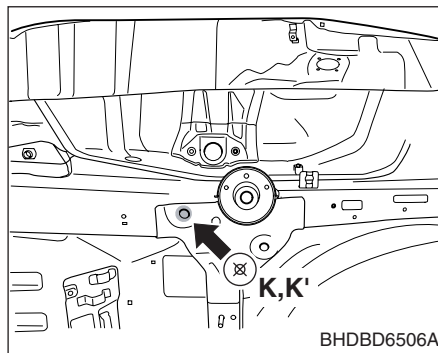

Rear suspension mounting hole (ϕ18)

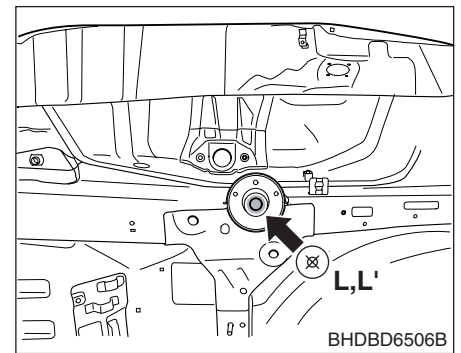

Spring mounting hole (ϕ20)

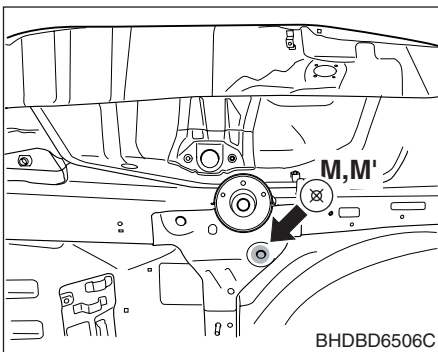

Cross Member mounting hole (ϕ18)

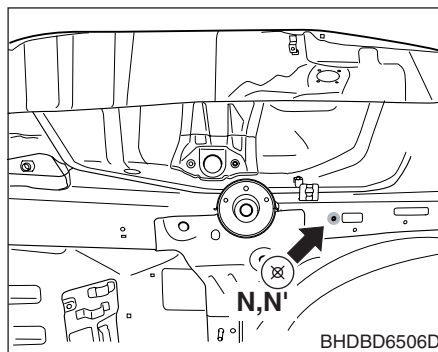

Filler pipe mounting hole (ϕ6.6)

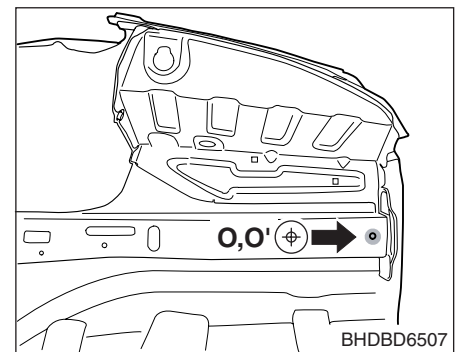

Tooling hole (ϕ10)

BODY PANEL REPAIR PROCEDURE

FENDER APRON PANEL ASSEMBLY

WELDING POINTS

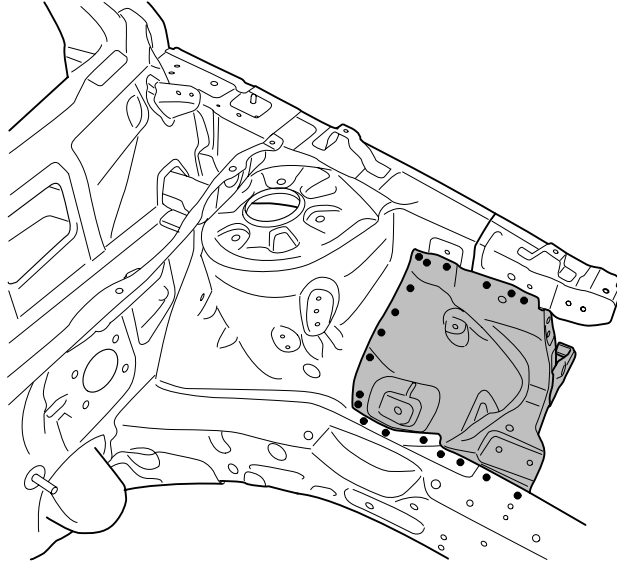

- MIG plug welding
- +++ MIG butt welding
- *-* MIG lap welding

BHDBP6202

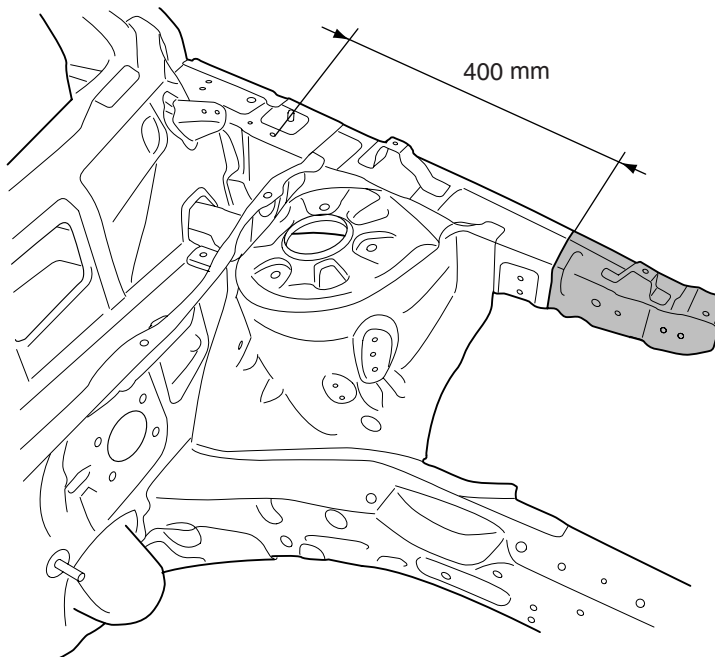

- MIG plug welding
- +++ MIG butt welding
- *-* MIG lap welding

BHDBP6203

REMOVAL

NOTE

Before repairing, remove Engine and Suspension Components.

Refer to the body dimension charts and measure the vehicle to determine straightening and alignment requirements. The body must be returned to its original dimension before beginning the repair procedure.

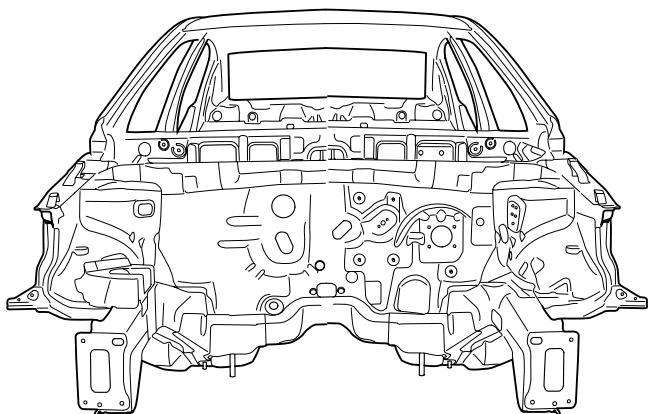

BHDBP6101

1. Drill out all the spotwelds(24) to separate fender apron lower panel from fender apron upper panel assembly and front side member assembly.

NOTE

When spotwelded portions are not apparent, remove paint with a rotary wire brush.

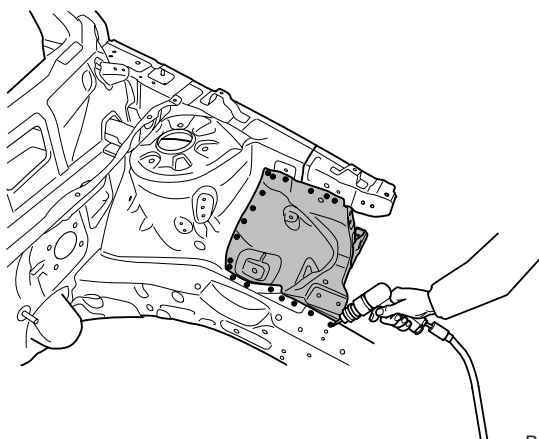

BHDBP6202

2. Remove the fender apron lower panel.
3. Measure and mark the cutline on the fender apron upper inner panel 400mm from front fender panel mounting hole center on the fender apron upper assembly as shown in the illustration.

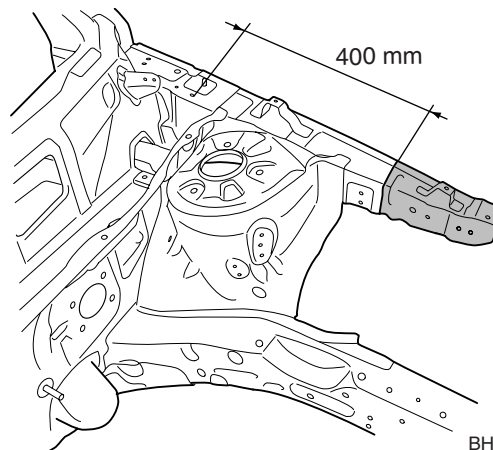

BHDBP6203A

4. Drill out all the spotwelds(33) to separate fender apron upper outer panel from fender apron upper panel assembly.

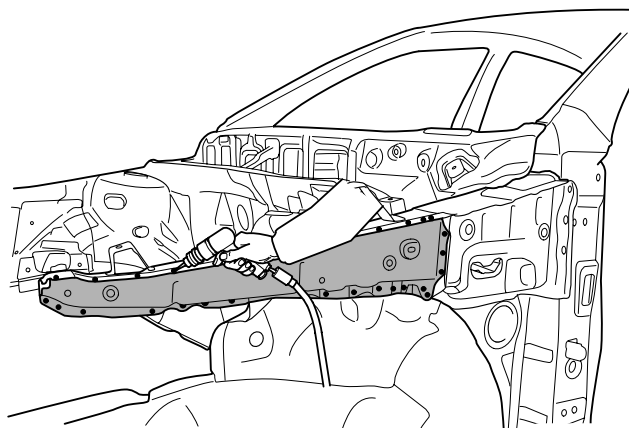

BHDBP6204

5. Remove the fender apron upper outer panel.

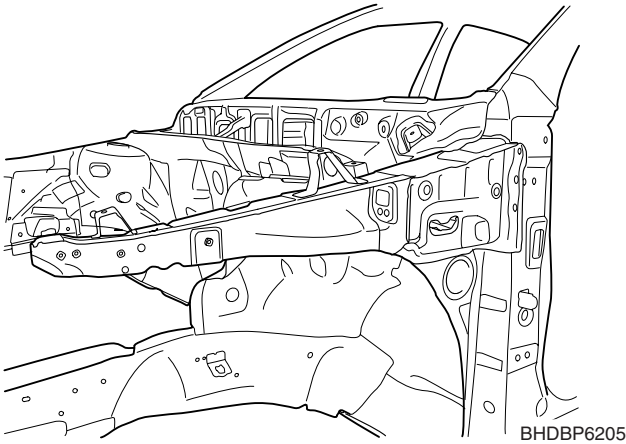

6. Cut through the fender apron upper inner panel along cutline.

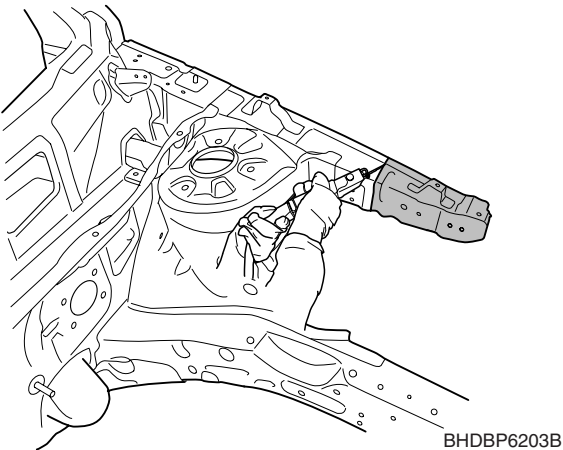

7. Remove the fender apron upper inner panel.

8. Prepare all surfaces to be welded.

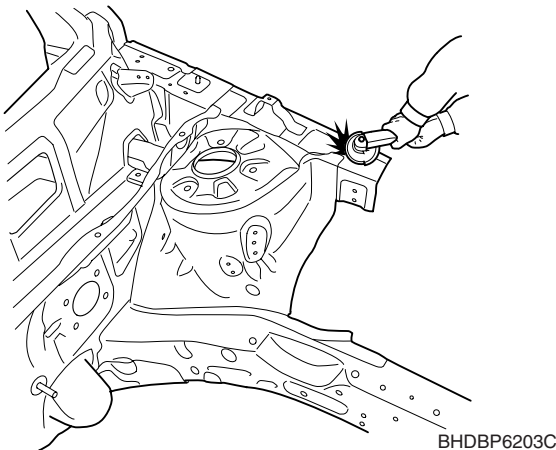

9. After removing, apply the welding primer.

INSTALLATION

1. Transcribe the fender apron upper inner panel cutline to the new fender apron upper inner panel, cut to length and chamfer butt end to improve weld surface.

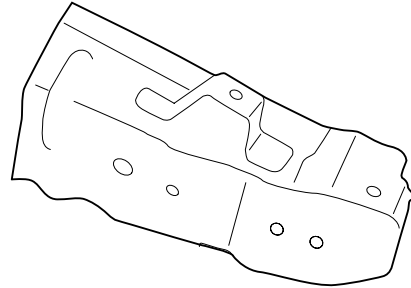

2. Fit and clamp the fender apron upper inner panel in place.
3. Measure each measurement point (Refer to the BODY DIMENSIONS) and correct the installation position.

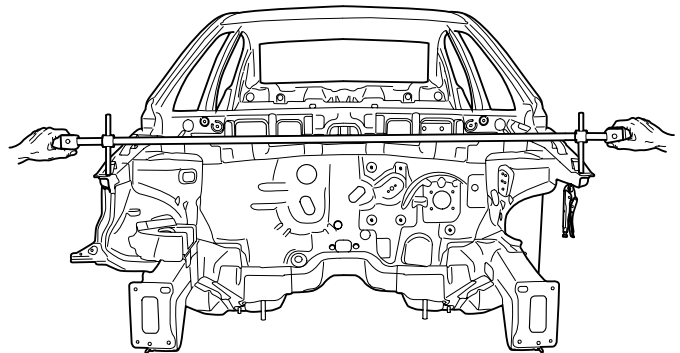

4. MIG plug weld all holes and MIG butt weld all seams.

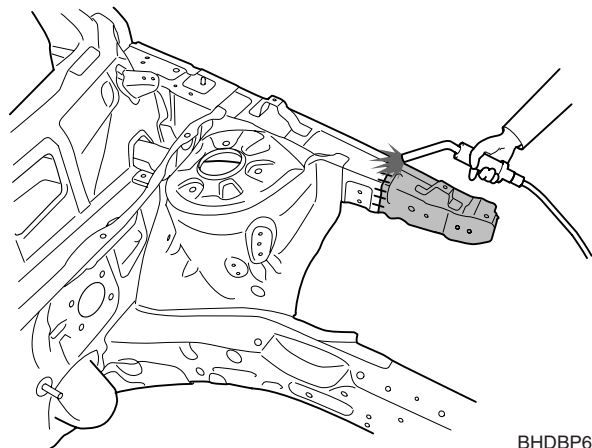

5. Clean and prepare all welds, and remove all residue.

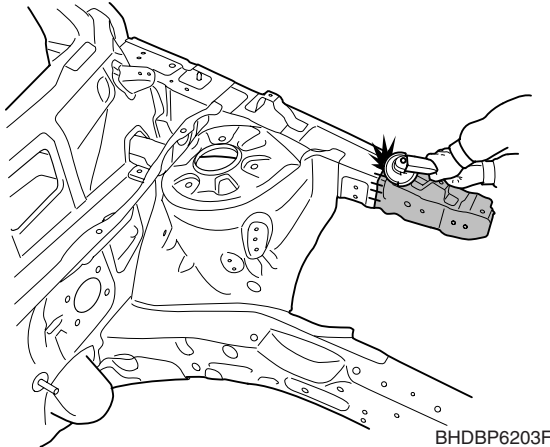

BHDBP6203F

6. Drill 6mm holes in the new fender apron upper outer panel for MIG plug welding.

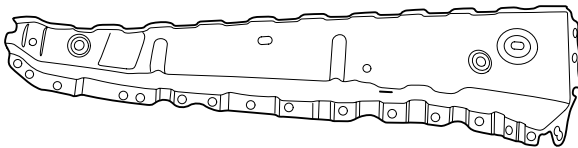

BHDBP6206

7. Fit and clamp the fender apron upper outer panel in place.
8. Measure each measurement point (Refer to the BODY DIMENSIONS) and correct the installation position.

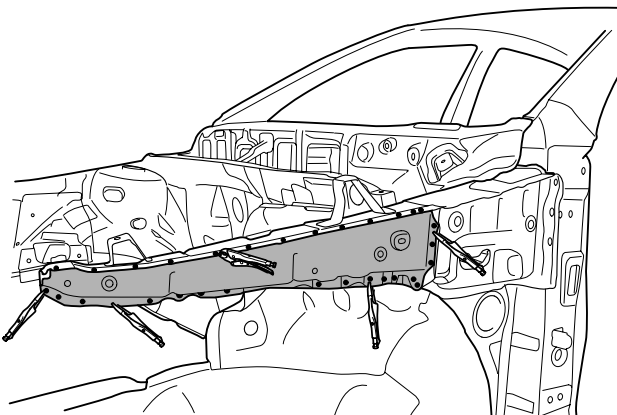

BHDBP6204

9. MIG plug weld all holes.

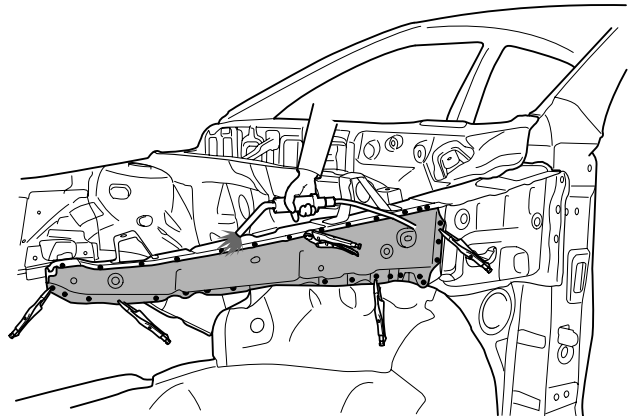

BHDBP6204B

10. Clean and prepare all welds, and remove all residue.

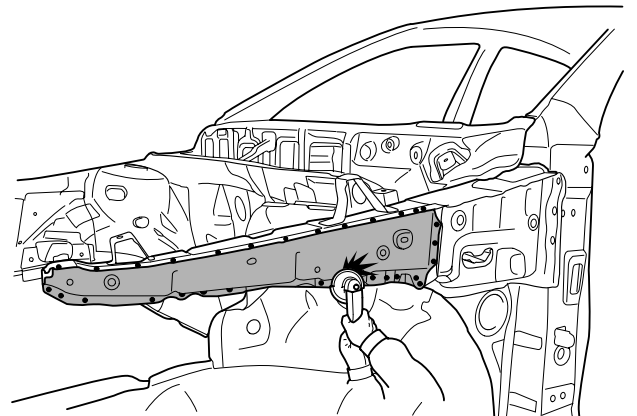

BHDBP6204C

11. Drill 6mm holes in the new fender apron lower panel for MIG plug welding.

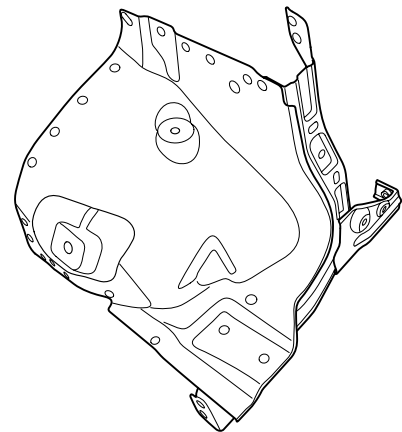

BHDBP6207

12. Fit and clamp the fender apron lower panel in place.
13. Measure each measurement point (Refer to the BODY DIMENSIONS) and correct the installation position.

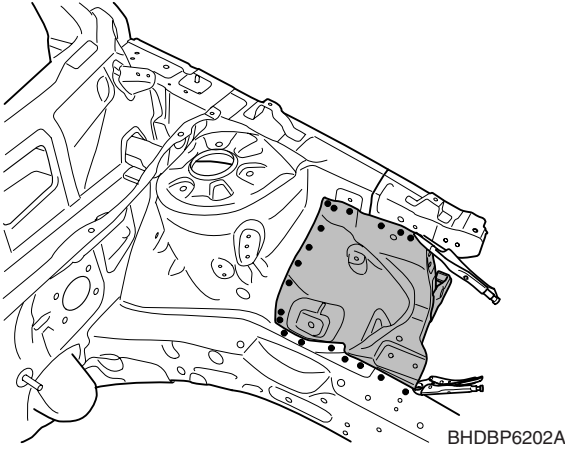

14. MIG plug weld all holes.

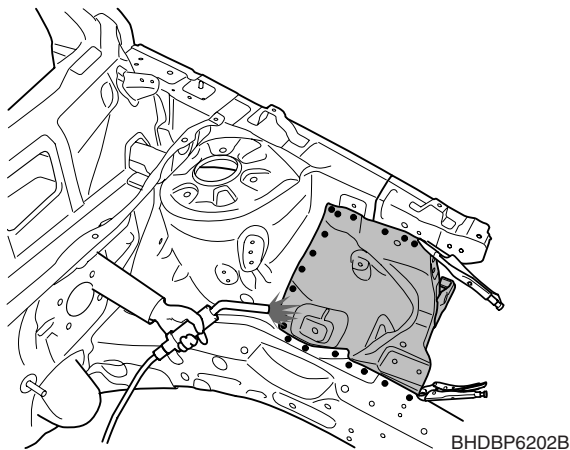

15. Clean and prepare all welds, and remove all residue.

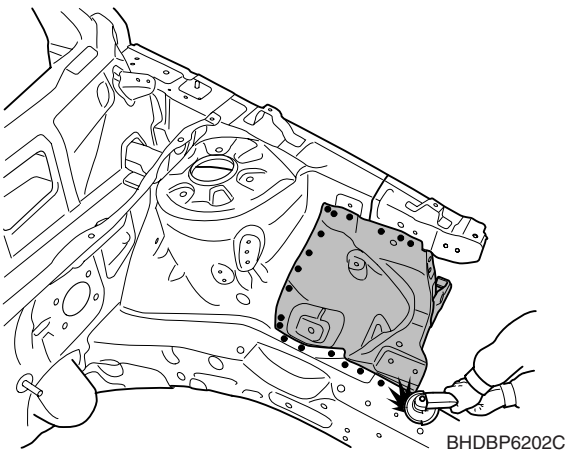

16. Apply the two part epoxy primer to the interior of the each panel.
17. Apply an anti-corrosion agent as required. (Refer to the BODY CORROSION PROTECTION)
18. Prepare the exterior surfaces for priming using wax and grease remover.
19. Apply metal conditioner and water rinse.
20. Apply conversion coating and water rinse.
21. Apply the two-part epoxy primer.

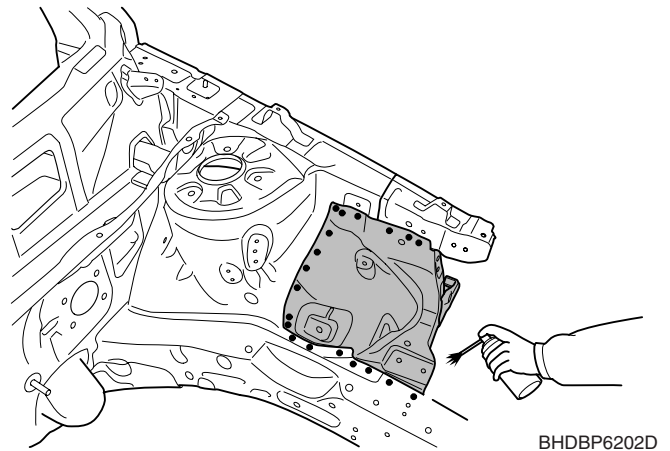

22. Apply the correct seam sealer to all joints carefully. (Refer to the BODY SEALING LOCATION)

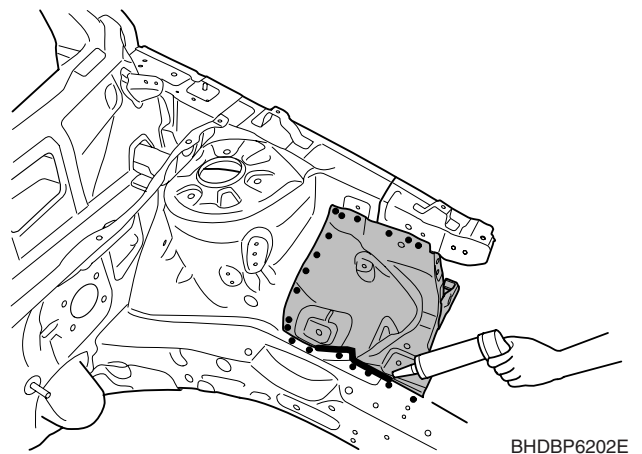

FRONT SIDE MEMBER

WELDING POINTS

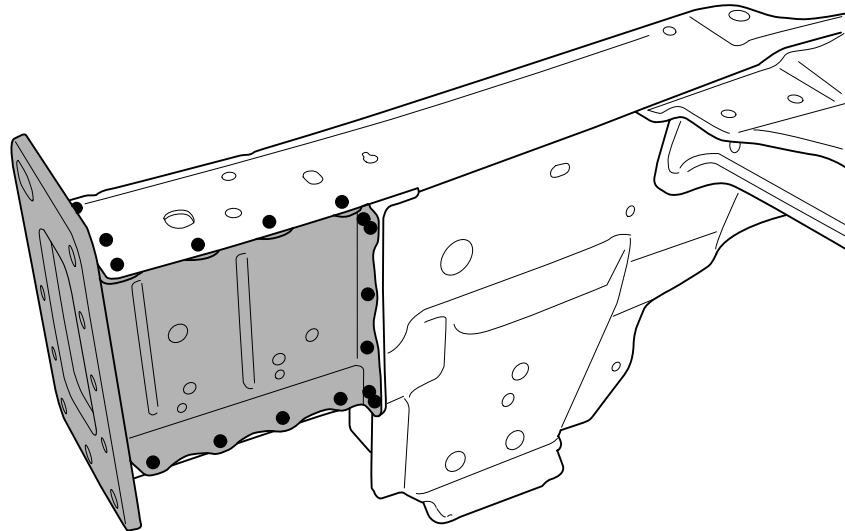

- MIG plug welding
- ≡≡≡ MIG butt welding
- ✕✕ MIG lap welding

BHDBP6102

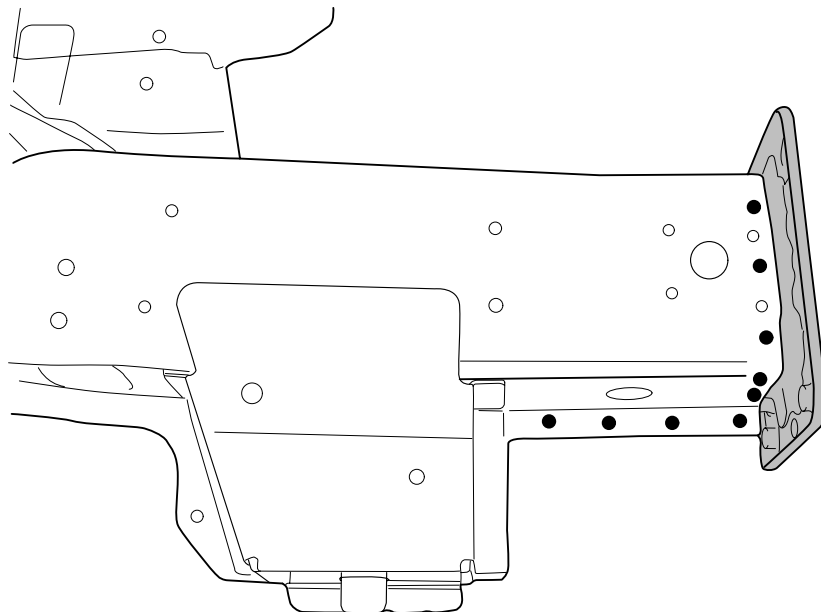

- MIG plug welding
- ≡≡≡ MIG butt welding
- ✕✕ MIG lap welding

BHDBP6103

 **NOTE**

This procedure is to be used only for repair of minor damage to the front side member and when it is impossible to straighten the damaged front side member. The following procedure illustrates a repair for the front left side member.

The procedure may also be applied to the front right side member.

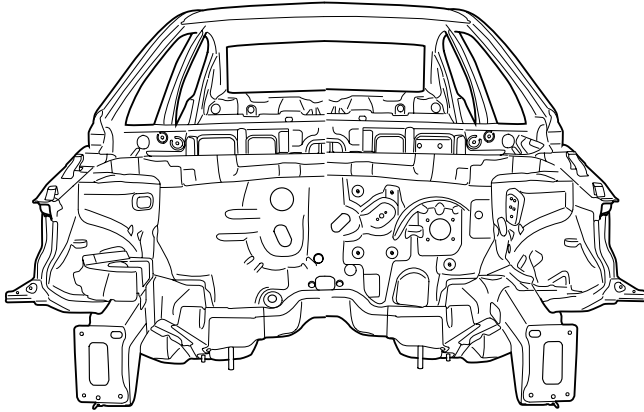

BHDBP6101

REMOVAL

1. Drill out all the spotwelds(21) to front bumper mounting bracket from front side member assembly.

 **NOTE**

When spotwelded portions are not apparent, remove paint with a rotary wire brush.

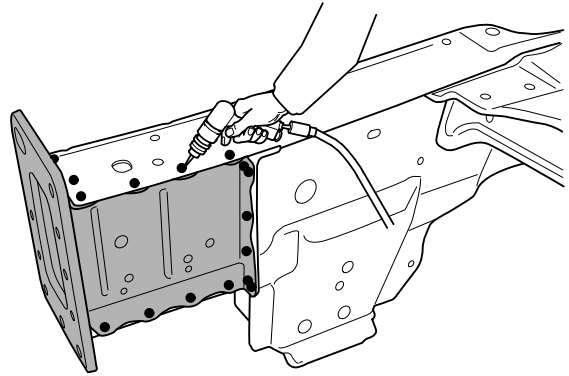

BHDBP6102A

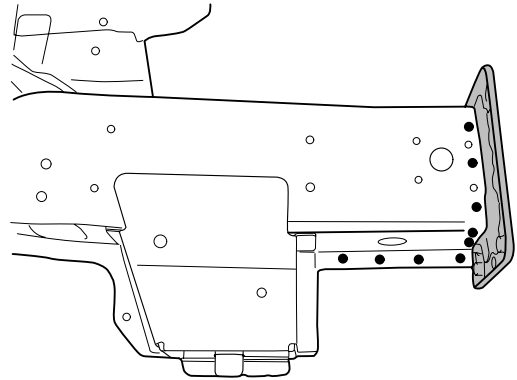

BHDBP6103A

2. Remove the front bumper mounting bracket.
3. Prepare all surfaces to be welded.

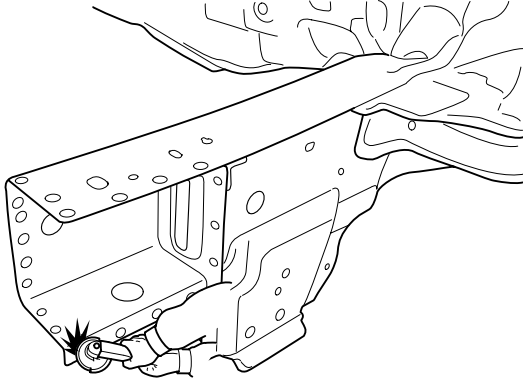

BHDBP6104

4. After removing, apply the welding primer.

INSTALLATION

1. Drill 6mm holes in the front bumper mounting bracket for MIG plug welding.

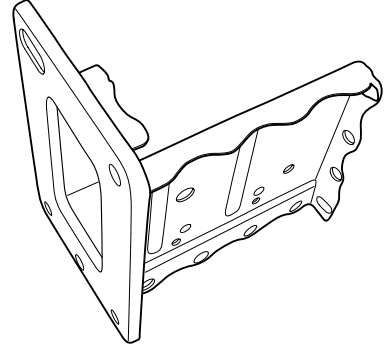

BHDBP6105

2. Fit and clamp the front bumper mounting bracket in place.
3. Measure each measurement point (Refer to the BODY DIMENSIONS) and correct the installation position.

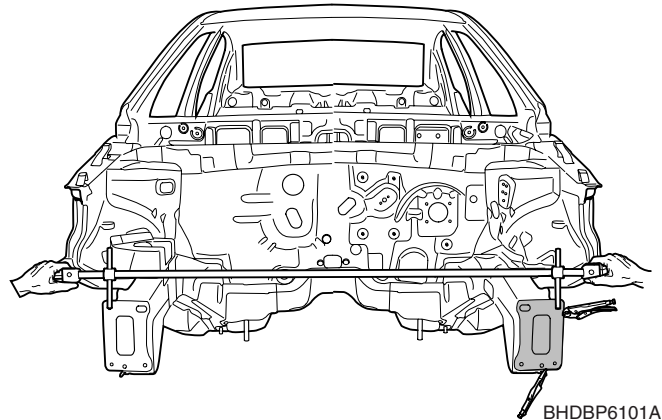

BHDBP6101A

4. MIG plug weld all holes.

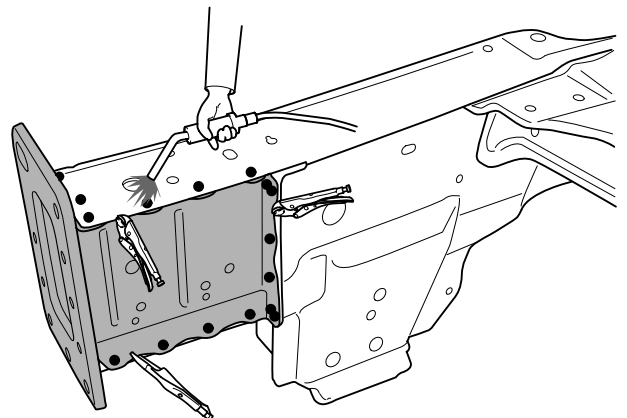

BHDBP6102B

5. Clean and prepare all welds, and remove all residue.

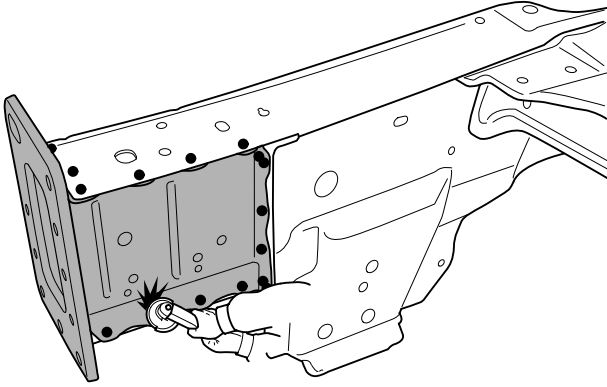

BHDBP6102C

6. Apply the two part epoxy primer to the interior of the each panel.
7. Apply an anti-corrosion agent as required.
(Refer to the BODY CORROSION PROTECTION)
8. Prepare the exterior surfaces for priming using wax and grease remover.
9. Apply metal conditioner and water rinse.
10. Apply conversion coating and water rinse.
11. Apply the two-part epoxy primer.

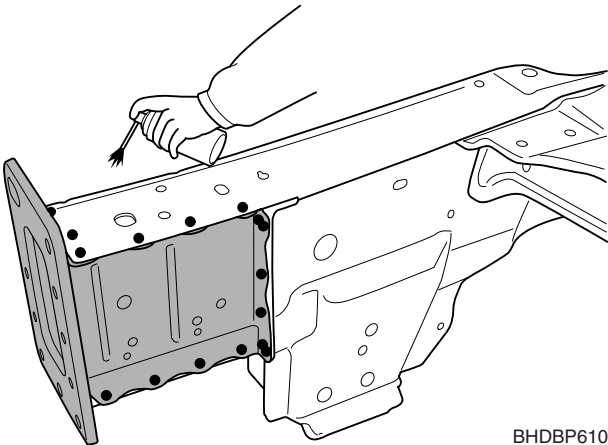

BHDBP6102D

12. Apply the correct seam sealer to all joints carefully.
(Refer to the BODY SEALING LOCATION)

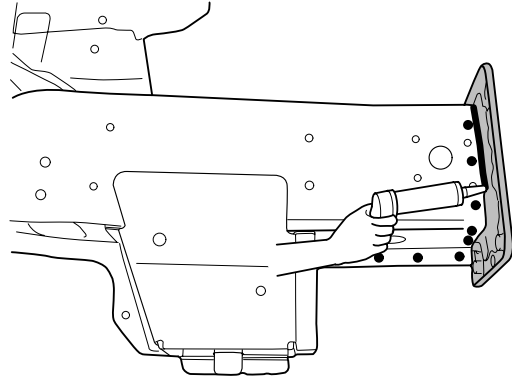

BHDBP6103B

FRONT PILLAR

WELDING POINTS

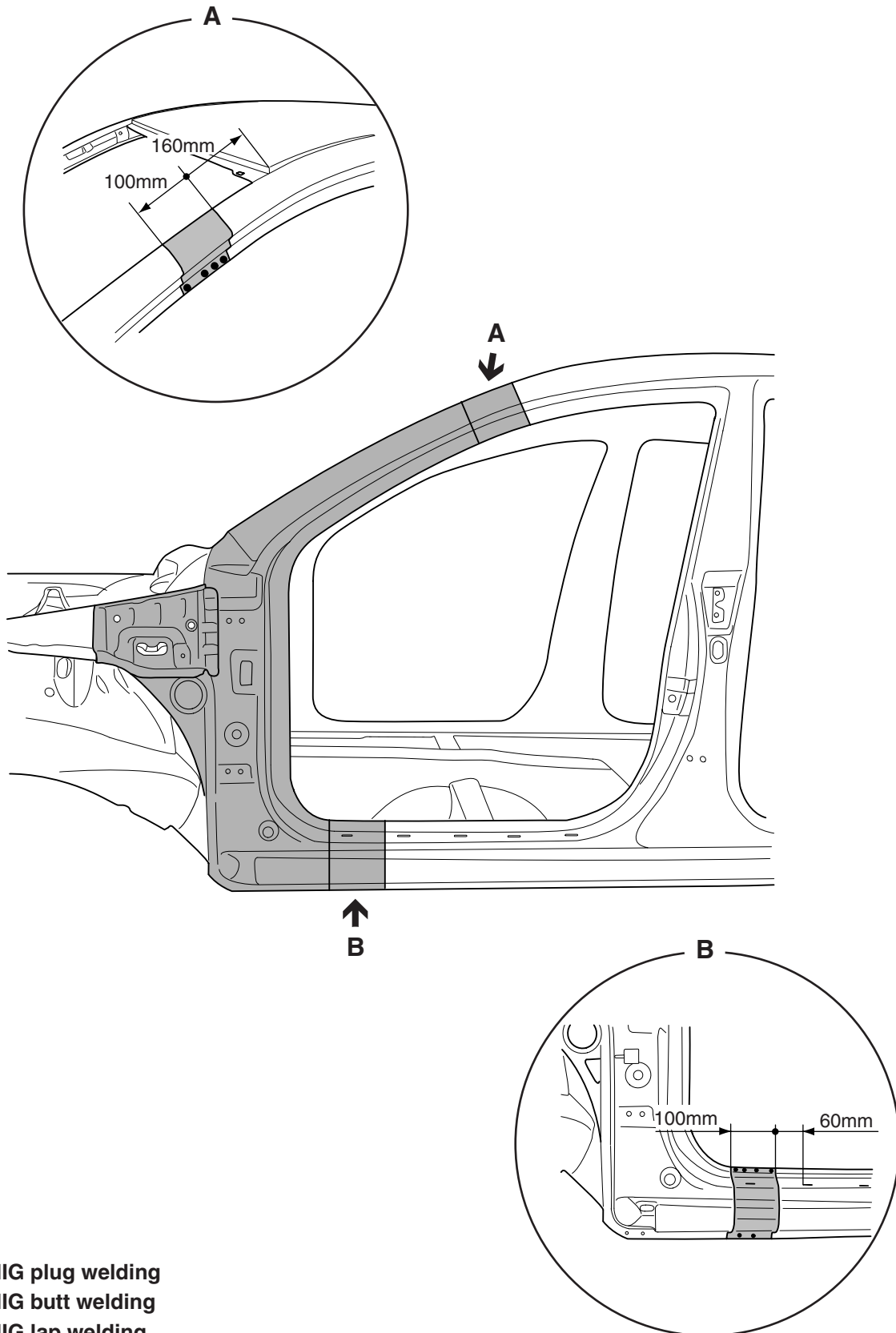

- MIG plug welding
- ≡≡≡ MIG butt welding
- ✖✖ MIG lap welding

REMOVAL

1. To remove the front pillar, drill out and grind away all spotwelds(20) and lap welds(4) attaching the cowl side upper outer panel as shown in the illustration.

 **NOTE**

If it is possible that the cowl side upper outer panel is reusable, be careful not to damage it while removing.

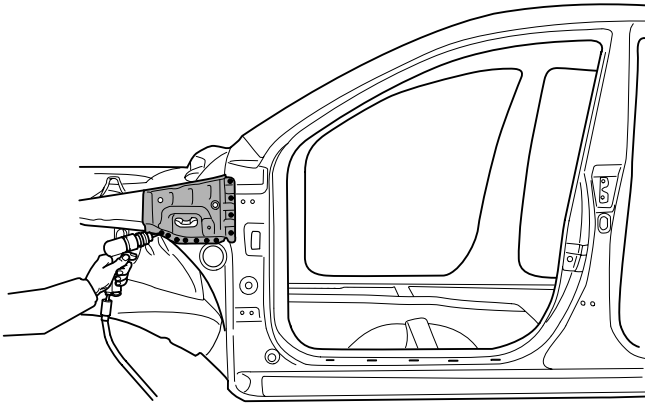

BHDBP6402

2. Remove the cowl side upper outer panel.
3. Before cutting front pillar, be sure to support roof panel.

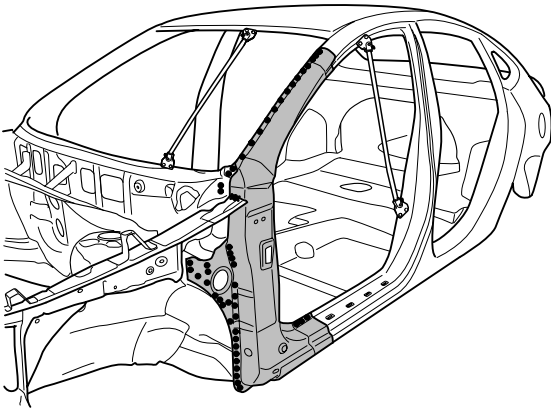

BHDBP6401

4. Measure and mark the each cutline on the front pillar outer panel 160mm and 260mm from the roof panel end line as indicated in the illustration.

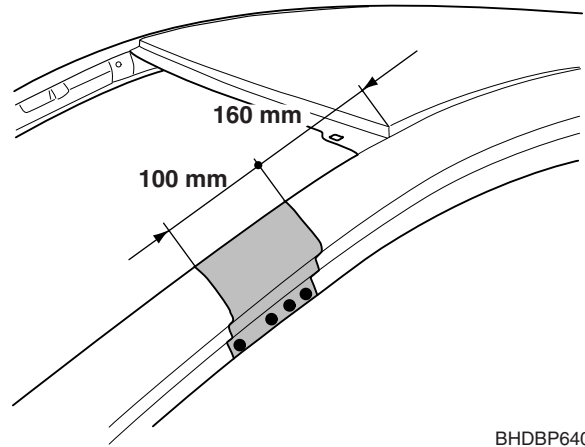

BHDBP6404

5. Cut the front pillar outer panel along each cutline, taking care not to damage the other panel as illustration.

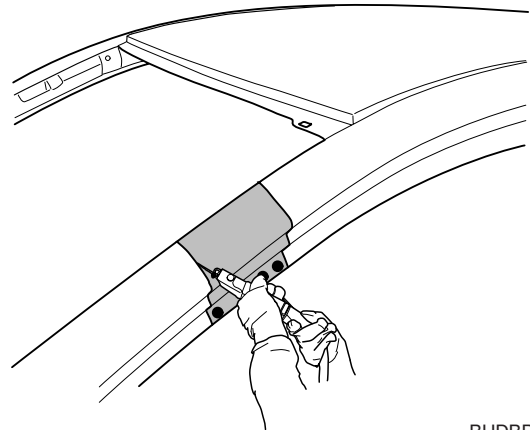

BHDBP6404A

6. Drill out all the spotwelds(8) attaching the front pillar outer panel.

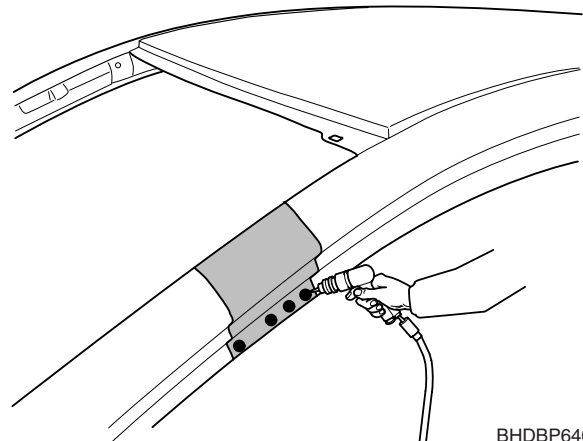

BHDBP6404B

7. Remove the front pillar outer panel.

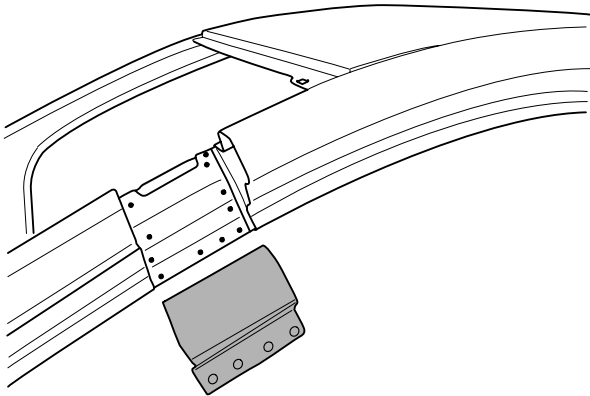

BHDBP6407

8. Drill out all the spotwelds(12) attaching the front pillar outer reinforcement.

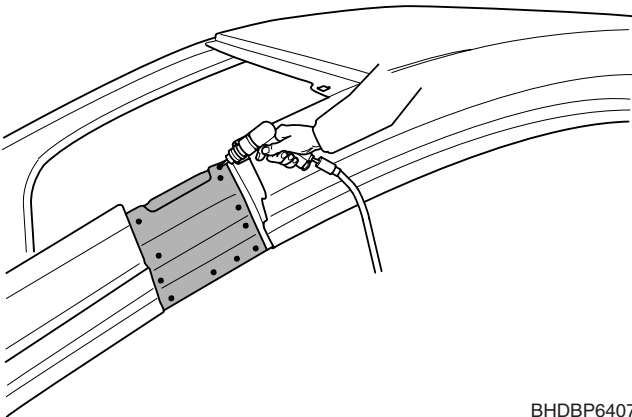

BHDBP6407A

9. Measure and mark the cutlines on front side sill outer panel as shown in the illustration.

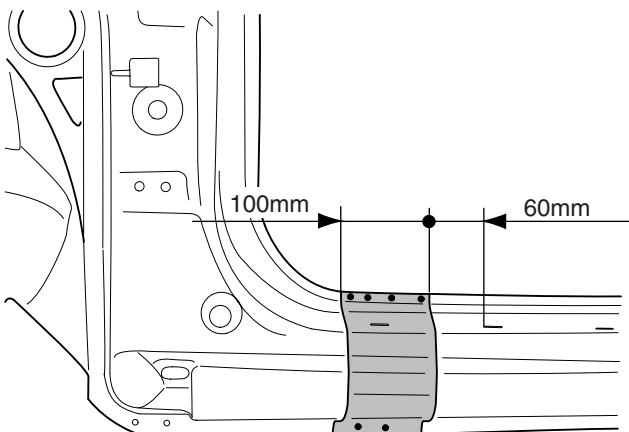

BHDBP6408C

10. Cut the front side sill outer panel.

NOTE

When cutting the front side sill outer panel, be careful not to cut side sill outer panel reinforcement.

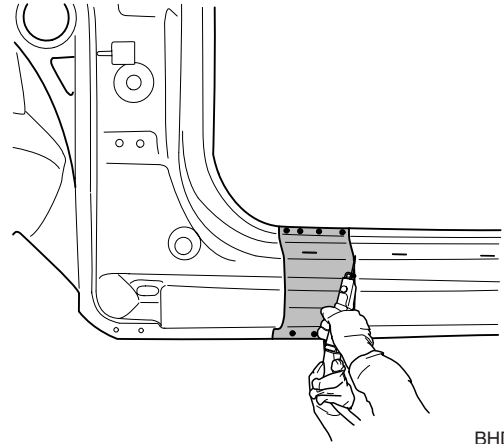

BHDBP6408A

11. Drill out all the spotwelds(7) attaching the front side sill outer panel.

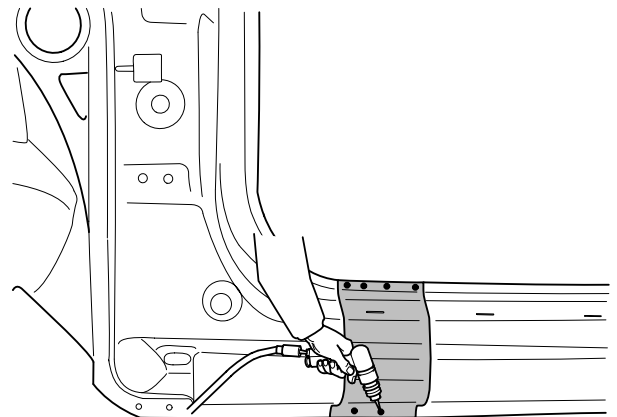

BHDBP6408B

12. Remove the front side sill outer panel.

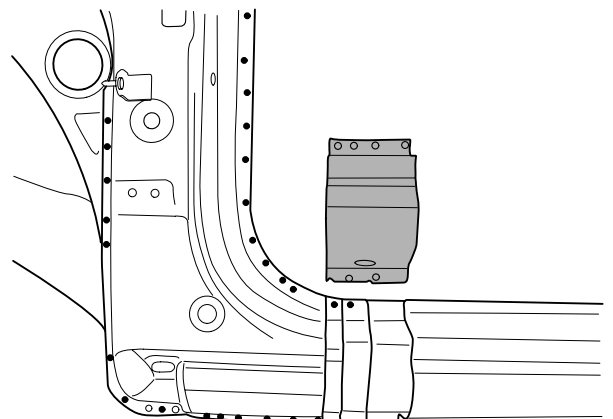

BHDBP6409

13. Cut the side sill outer panel reinforcement along outline, taking care not to damage the other panel as illustration.

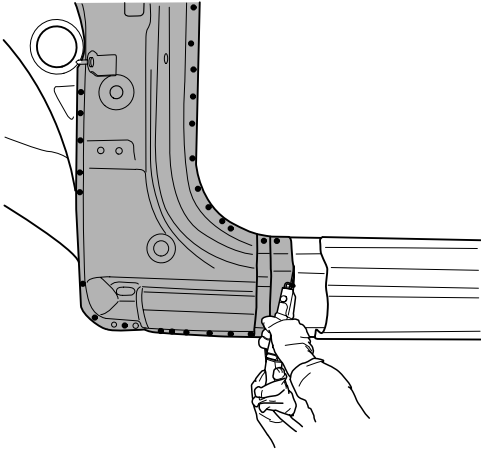

BHDBP6409A

14. To remove the front pillar outer panel, drill out and grind away all spotwelds(88) and lap weld(1) attaching the front pillar outer panel.

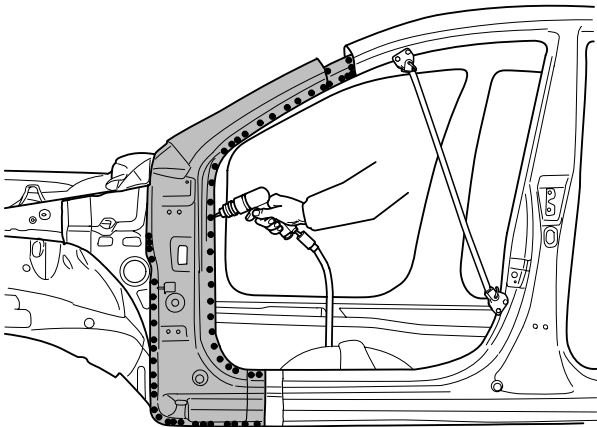

BHDBP6410

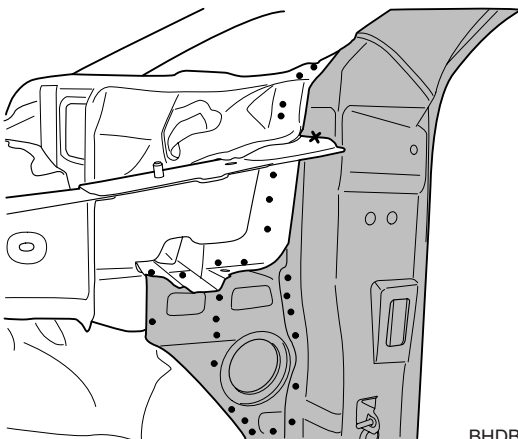

BHDBP6411

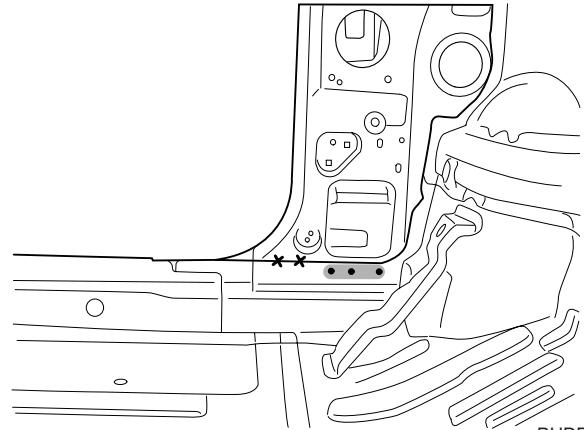

BHDBP6412

15. Remove the front pillar outer panel.

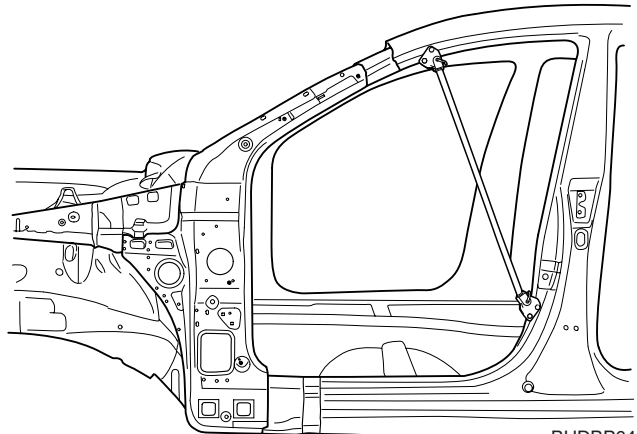

BHDBP6413

16. To remove the front pillar inner panel, drill out and grind away all spotwelds(35) and lap welds(4) attaching the front pillar inner panel.

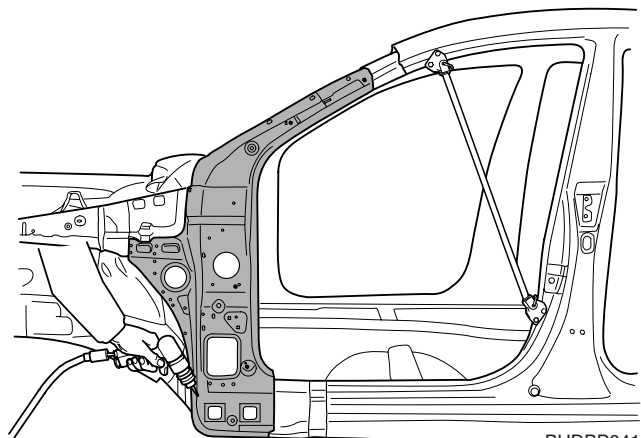

BHDBP6413A

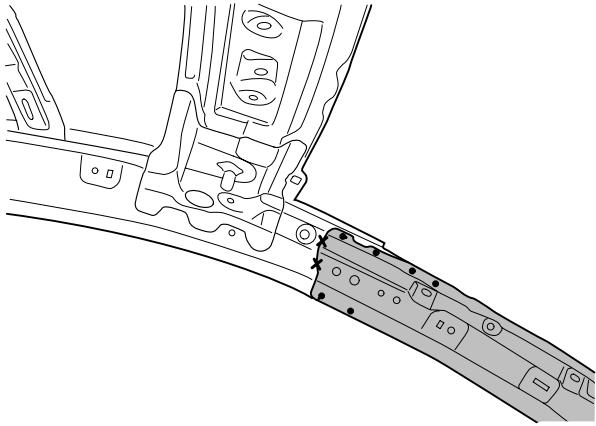

BHDBP6414

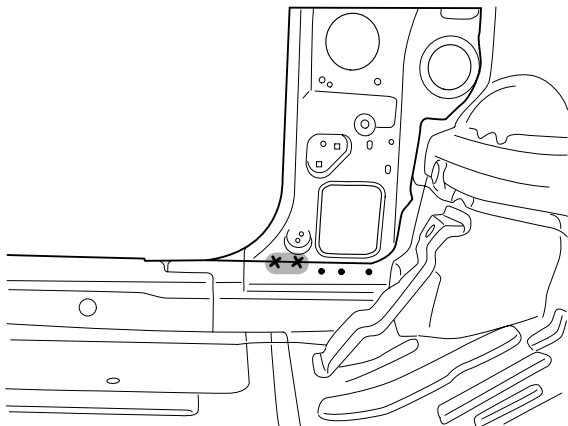

BHDBP6412A

17. Remove the front pillar inner panel.

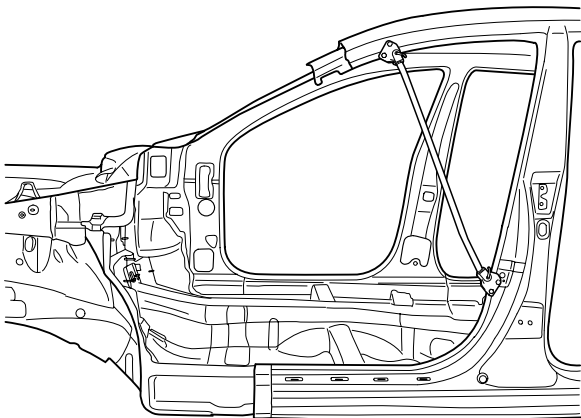

BHDBP6415

18. Clean cut portions with a disc grinder.

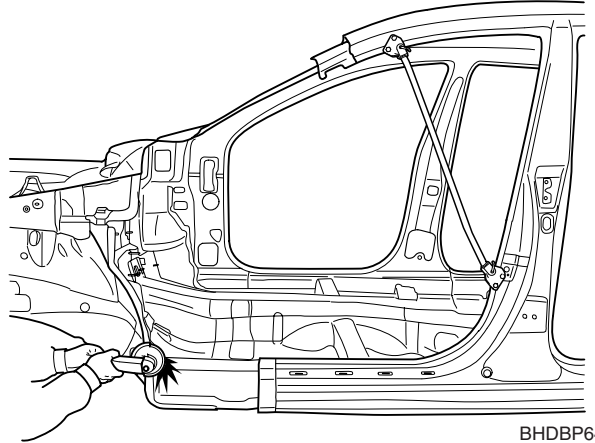

BHDBP6415A

19. After removing, apply the welding primer.

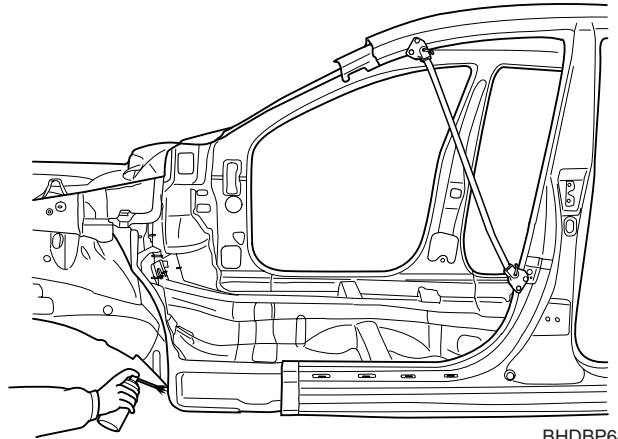

BHDBP6415B

INSTALLATION

1. Drill 6mm holes in the front pillar inner panel for MIG plug welding.

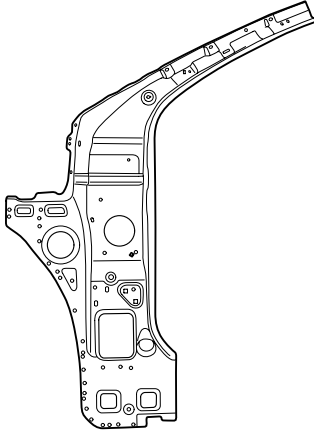

BHDBP6416

2. Fit and clamp the new front pillar inner panel in place for welding.
3. Measure and each measurement point (Refer to the BODY DIMENSIONS) and correct the installation position.

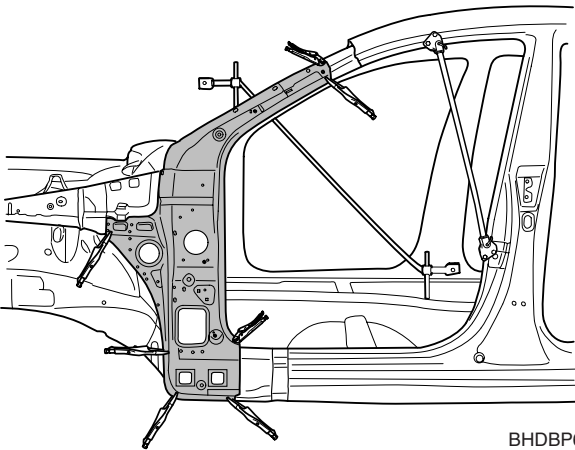

BHDBP6413B

4. MIG plug weld all holes and MIG lap weld seams.

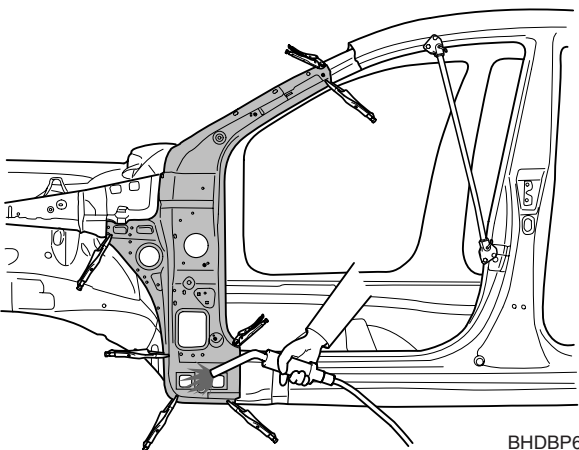

BHDBP6413C

5. Clean and prepare all welds, and remove all residue.

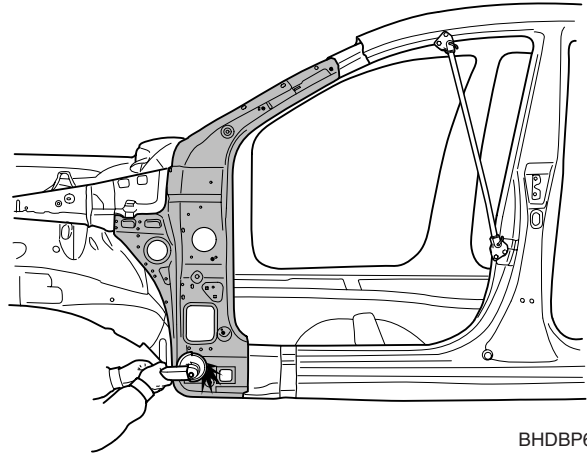

BHDBP6413D

6. After removing, apply the welding primer.

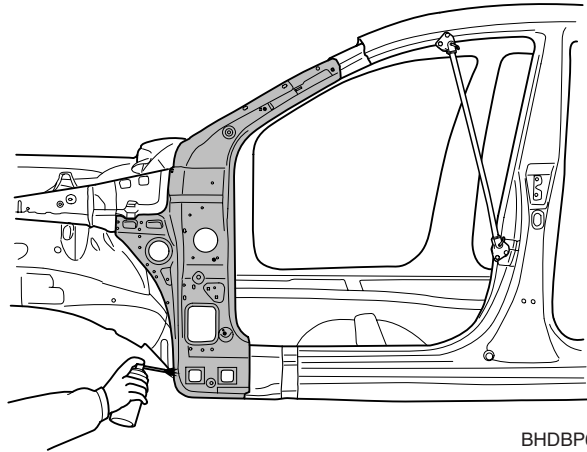

BHDBP6413E

7. Transfer the cutline dimensions to the new front pillar outer panel, adding 30mm overlap to each end and cut to length.
8. Drill 6mm holes along front pillar outer panel flanges in production location for attachment to other panels.

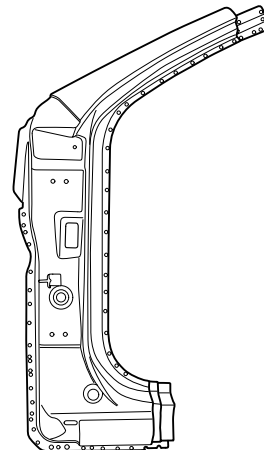

BHDBP6417

- 9. Install the front pillar outer panel in place.
- 10. Measure each measurement point (Refer to the BODY DIMENSIONS) and correct the installation position.

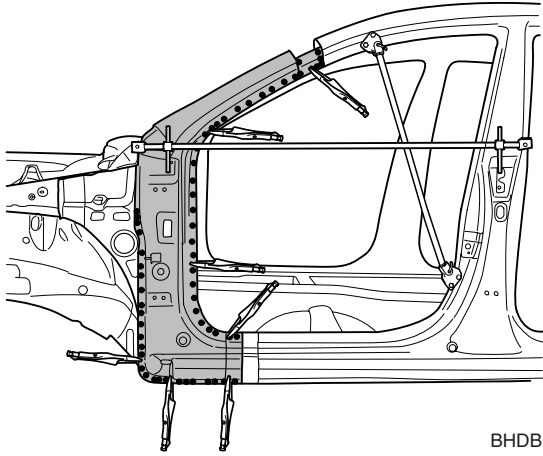

BHDBP6410A

- 11. MIG plug weld all holes and MIG lap weld seams.

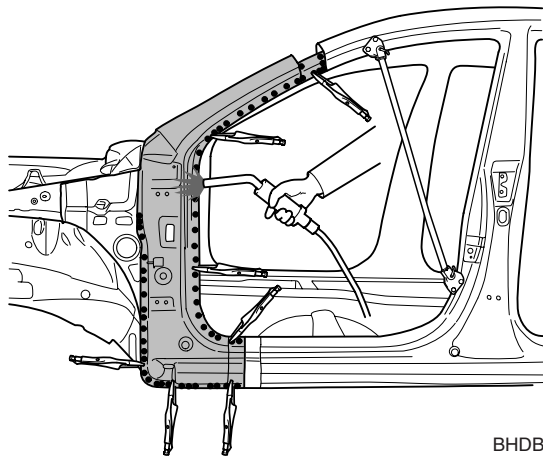

BHDBP6410B

- 12. Clean and prepare all welds, and remove all residue.

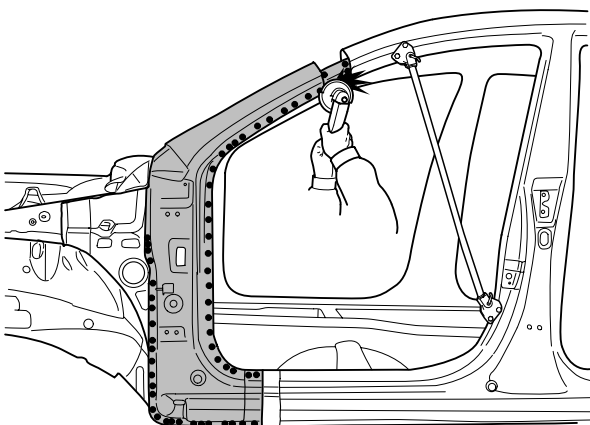

BHDBP6410C

- 13. After removing, apply the welding primer.

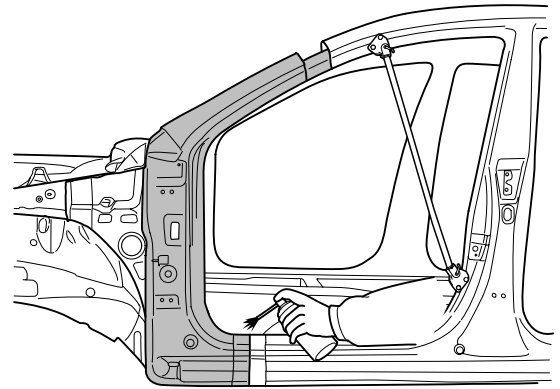

BHDBP6410B

- 14. Reattach the cut away front pillar outer panel section, then MIG plug weld all holes and MIG butt weld.

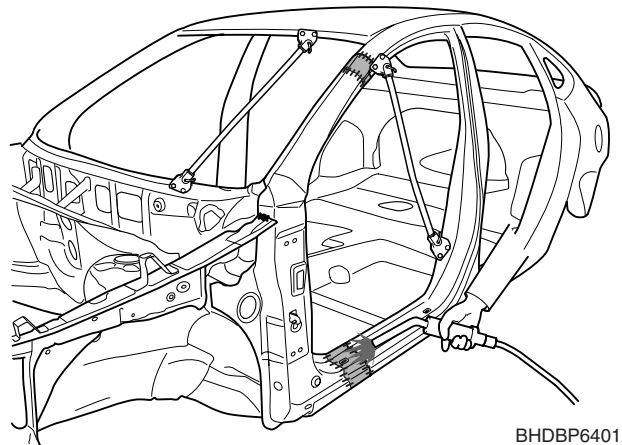

BHDBP6401A

- 15. Clean all welds with a disc grinder.

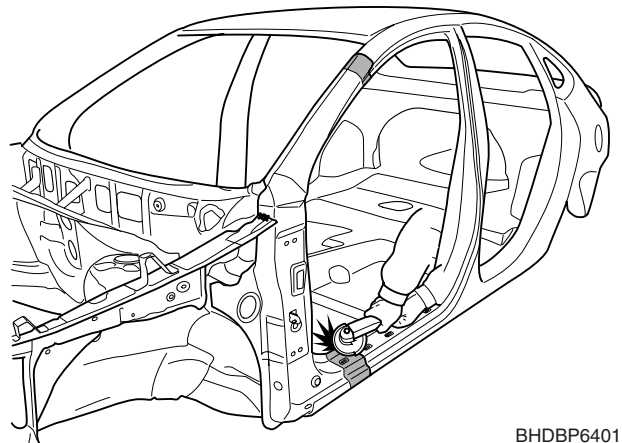

BHDBP6401B

16. After removing, apply the welding primer.
17. Apply the two-part epoxy primer to the interior of the front pillar.

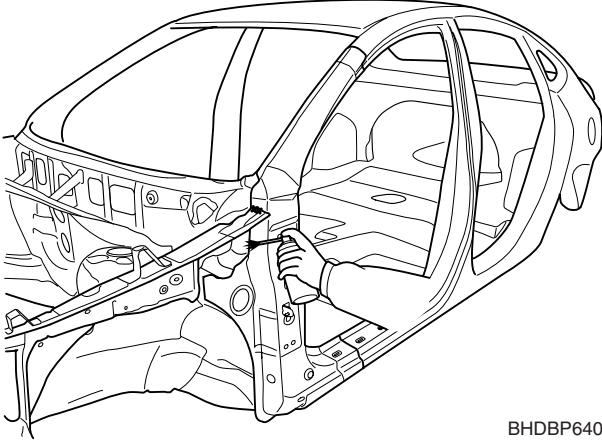

BHDBP6401C

18. Before welding the cowl side upper outer panel, apply the two part epoxy primer and anti-corrosion agent to the interior of the fender apron panel.

19. Install the cowl side upper outer panel in place.

21. MIG plug weld all holes.

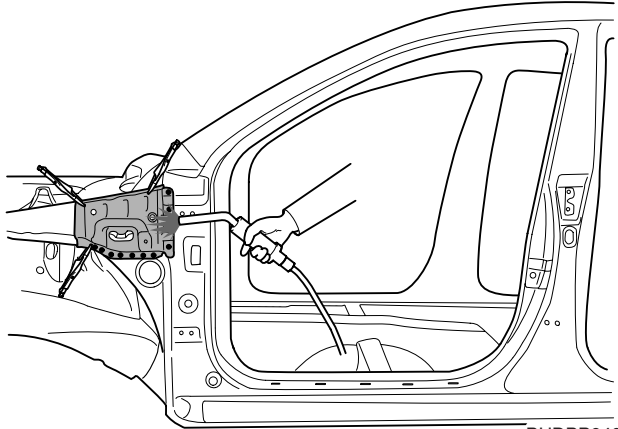

BHDBP6402A

20. Clean and prepare all welds, remove all residue.

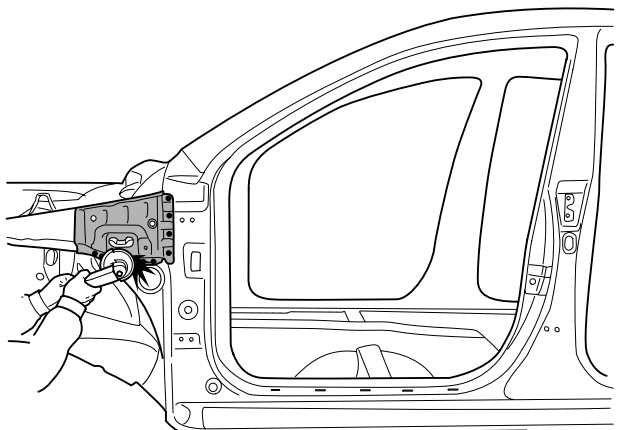

BHDBP6402B

21. Apply an anti-corrosion agent to the welded parts and inside of front pillar (Refer to the CORROSION PROTECTION).
22. Prepare exterior surfaces for priming, using wax and grease remover.
23. Apply metal conditioner and water rinse.
24. Apply conversion coating and water rinse.
25. Apply the two-part epoxy primer.

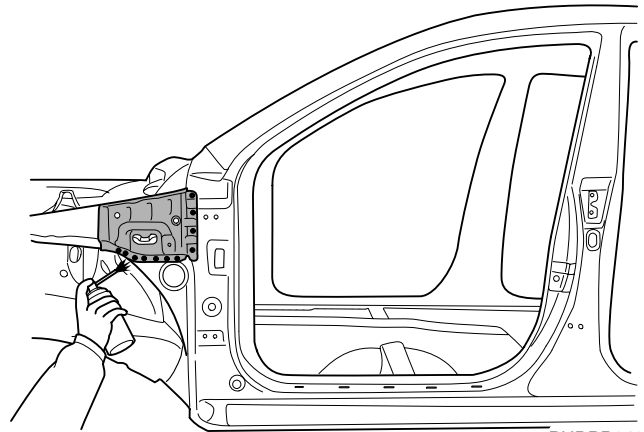

BHDBP6402C

26. Apply the correct seam sealer to all joints carefully (Refer to the BODY SEALING LOCATIONS).
27. Reprime over the seam sealer to complete the repair.

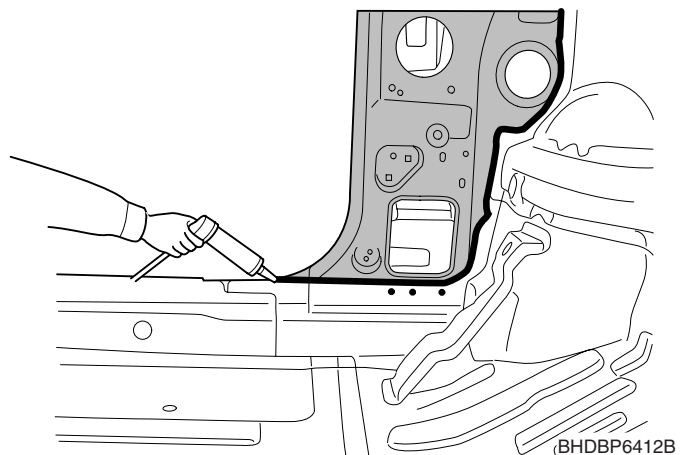

BHDBP6412B

SIDE SILL PANEL

WELDING POINTS

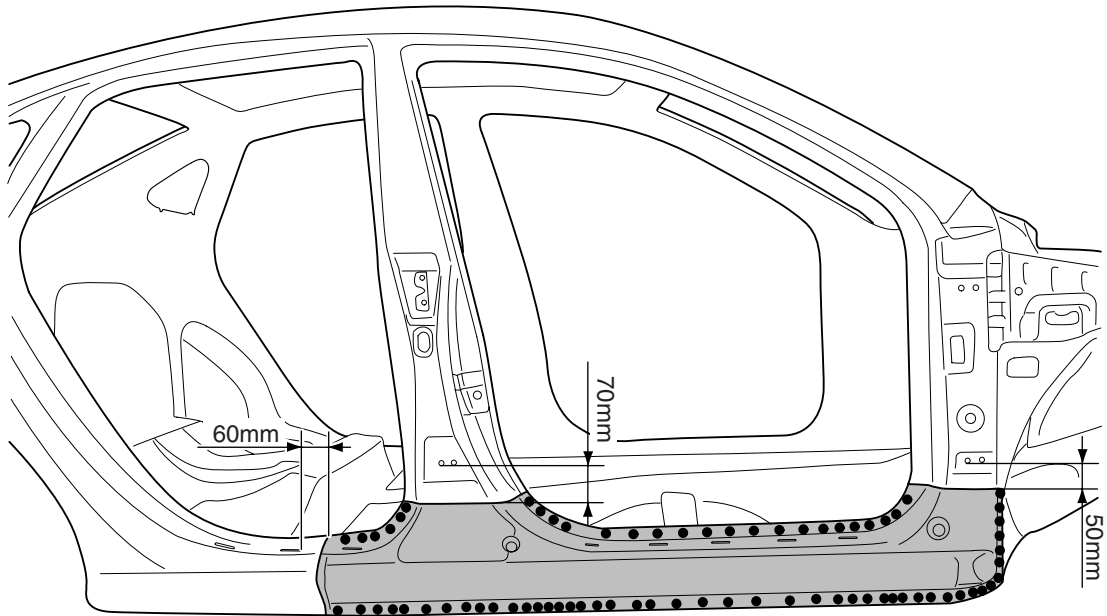

- MIG plug welding
- ⊞ MIG butt welding
- ⊞/ MIG lap welding

BHDBP6301

REMOVAL

1. Measure and mark the horizontal cutline on front pillar outer panel 50mm from the door hinge mounting hole as indicated in the illustration.

2. Measure and mark the horizontal cutline on center pillar outer panel 70mm from the door hinge mounting hole.
3. Measure and mark the vertical cutline on rear side sill outer panel 60mm from the rear door step trim mounting hole as indicated in the illustration.

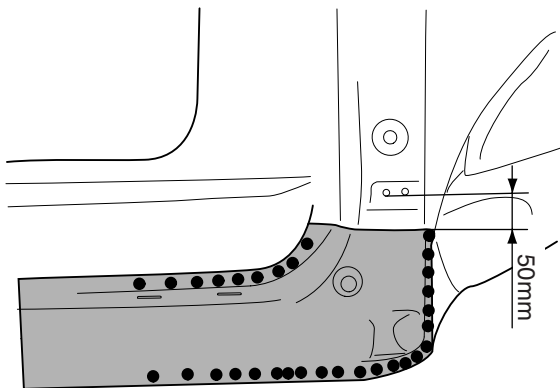

BHDBP6301A

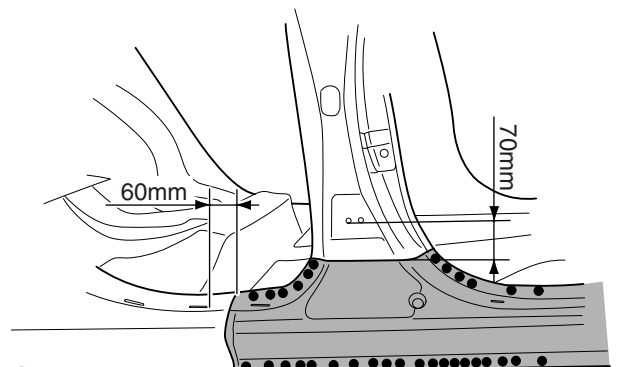

BHDBP6301B

4. Cut the side sill outer panel along cutlines. Be careful not to cut mating flanges.

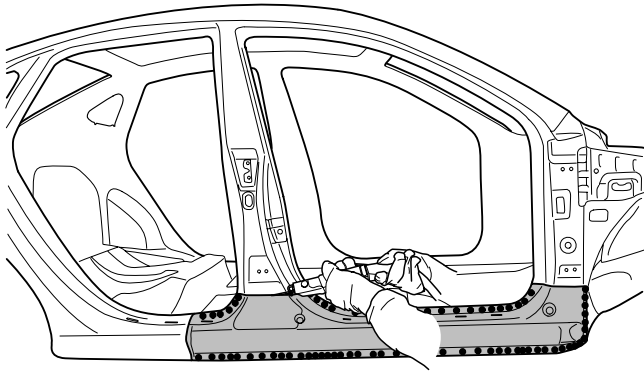

BHDBP6301C

5. Drill out all spotwelds(79), attaching the side sill outer panel to the side sill panel assembly.

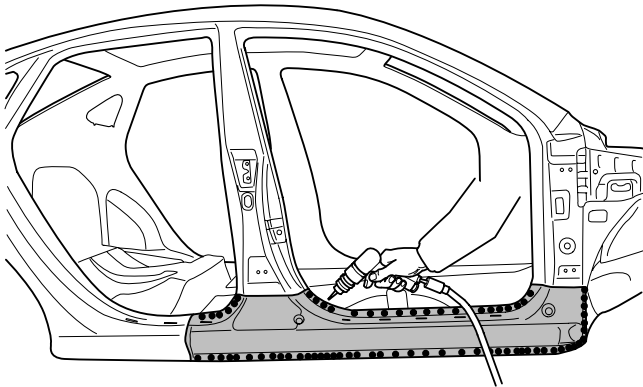

BHDBP6301D

6. Remove the side sill outer panel.

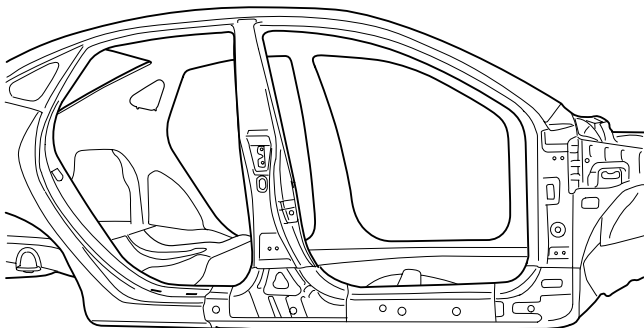

BHDBP6302

7. Clean cut portions with a disc grinder.

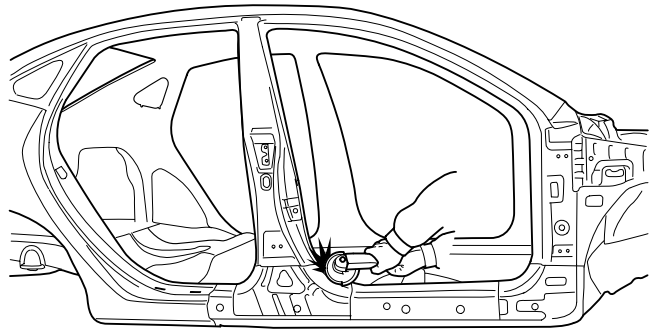

BHDBP6302A

8. After removing, apply the welding primer.

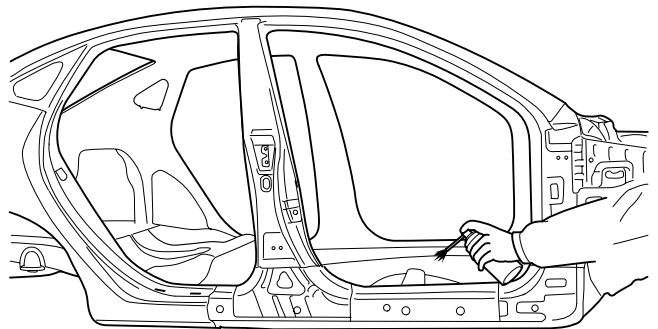

BHDBP6302B

INSTALLATION

1. Transcribe cutline dimensions to side sill outer panel, adding 30mm overlap to each end and cut to length.
2. Using service panel for replacement of side sill outer panel, drill 6mm holes in overlap areas and along upper and lower flanges.

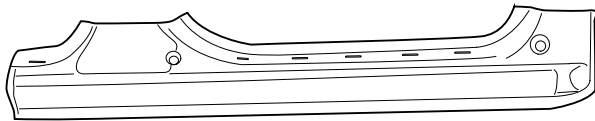

BHDBP6301E

3. Fit and clamp the side sill outer reinforcement in place.
4. Measure and each measurement point (Refer to the BODY DIMENSIONS) and correct the installation position.

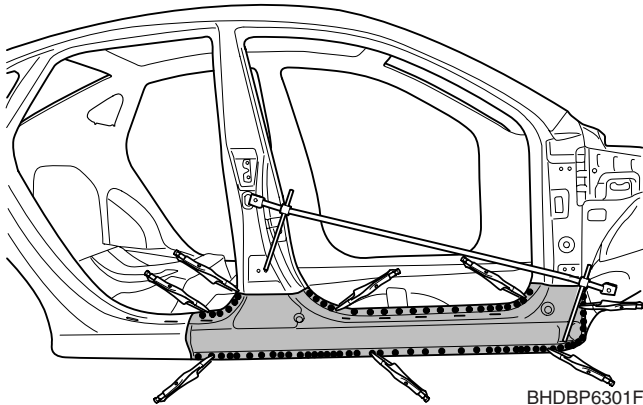

BHDBP6301F

5. MIG plug weld all holes and MIG butt weld seams.

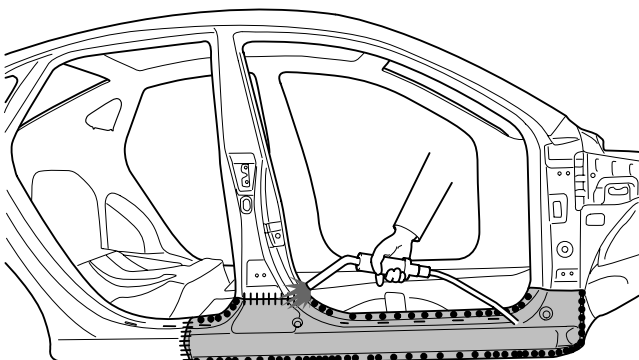

BHDBP6301G

6. Clean and prepare all welds and remove all residue.

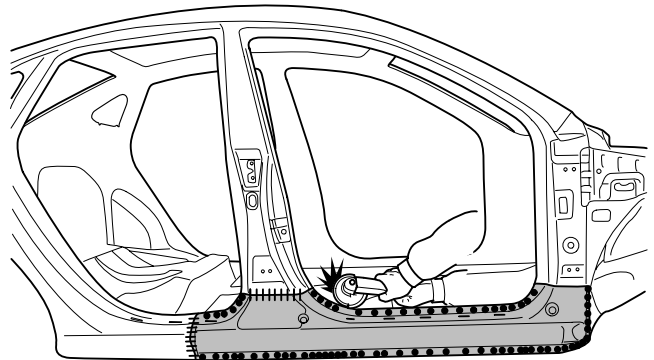

BHDBP6301H

7. Apply body filler to the side sill outer seams.
8. Apply the two-part epoxy primer to the interior of the side sill.
9. Apply an anti-corrosion agent to welded parts and interior of the side sill (Refer to the CORROSION PROTECTION).

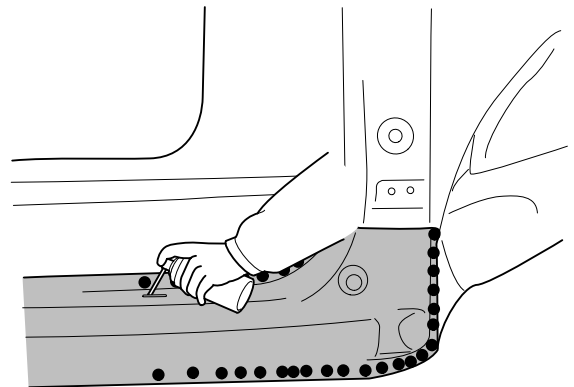

BHDBP6301I

10. Prepare the exterior surfaces for priming, using wax and grease remover.
11. Apply metal conditioner and water rinse.
12. Apply conversion coating and water rinse.
13. Apply the two-part epoxy primer.
14. Apply the correct seam sealer to all joints (Refer to the BODY SEALING LOCATIONS).
15. Reprime over the seam sealer.

CENTER PILLAR

WELDING POINTS

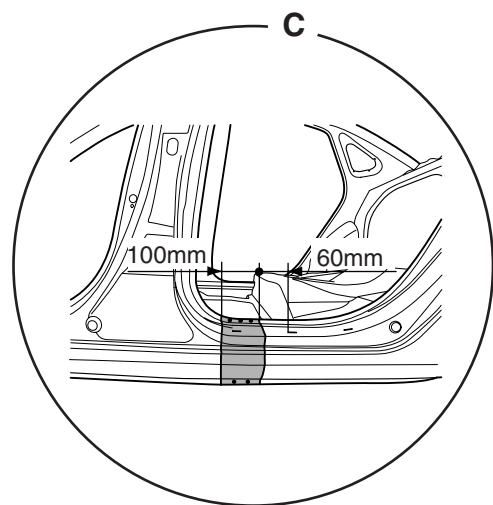
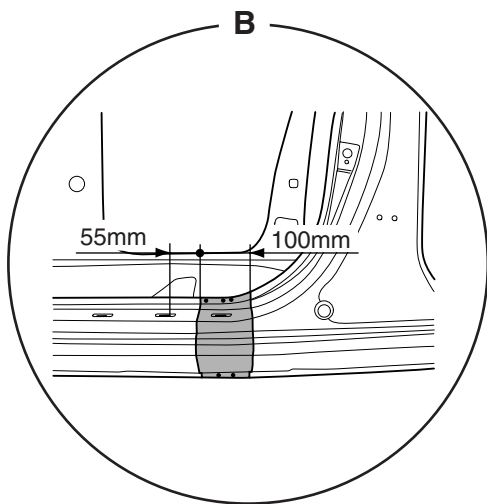
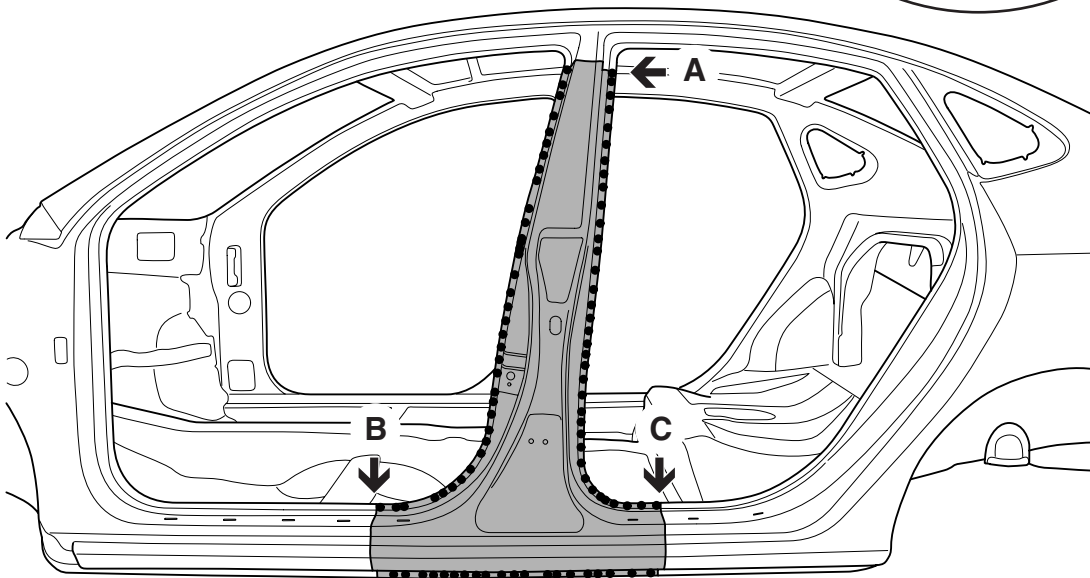
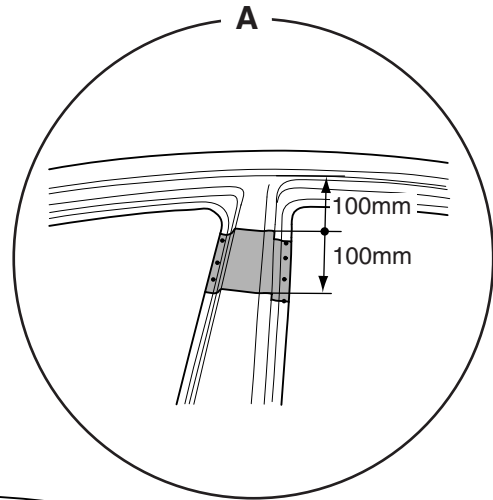

- MIG plug welding
- +++ MIG butt welding
- ✕✕ MIG lap welding

REMOVAL

1. Before cutting center pillar, be sure to support roof panel.

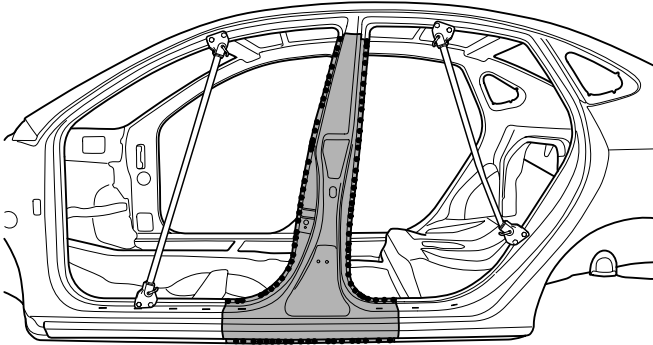

BHDBP6501

2. Measure and mark the horizontal cutlines on center pillar outer panel as indicated in the illustration.

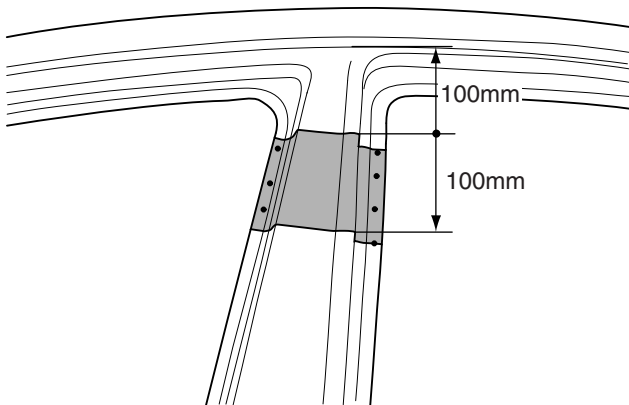

BHDBP6502

3. Cut center pillar outer panel at cutlines.



NOTE

When cutting center pillar outer panel, take care not to cut through mating flanges or center pillar outer reinforcement.

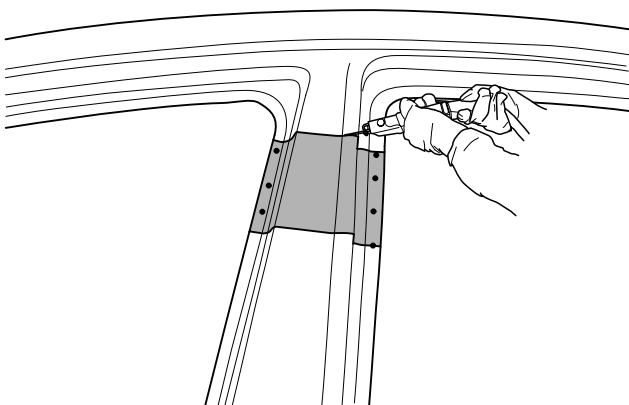

BHDBP6502A

4. Drill out all spotwelds(7), attaching the center pillar outer panel to the center pillar assembly.

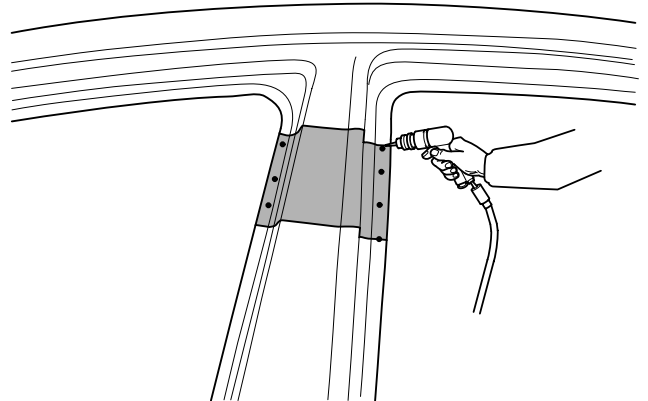

BHDBP6502B

5. Remove the center pillar outer panel.

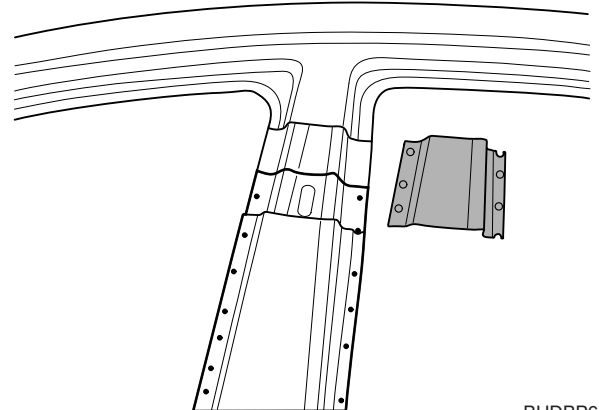

BHDBP6503

6. Measure and mark the horizontal cutline on center pillar outer reinforcement as indicated in the illustration.

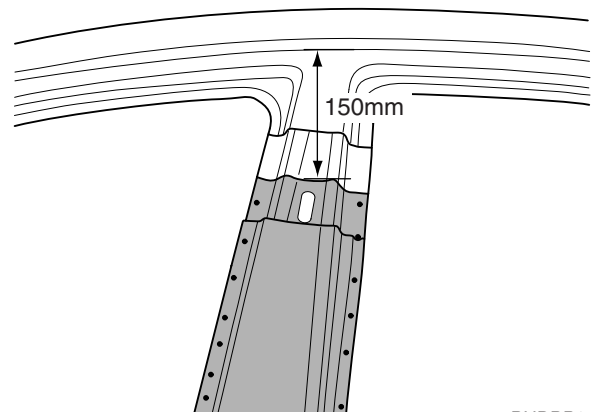

BHDBP6503A

7. Cut center pillar outer reinforcement at cutline.

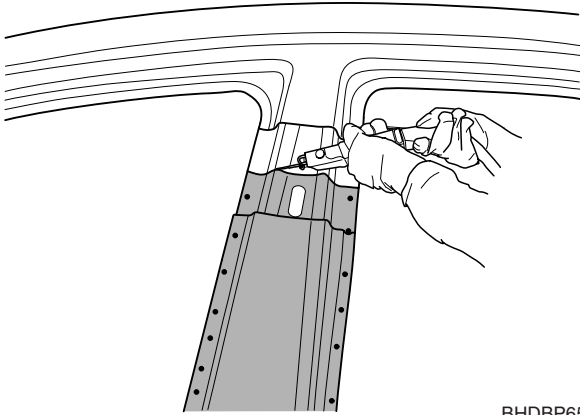

BHDBP6503B

8. Measure and mark the vertical cutlines on front side sill outer panel 55mm and 155mm from the front door step trim mounting hole.

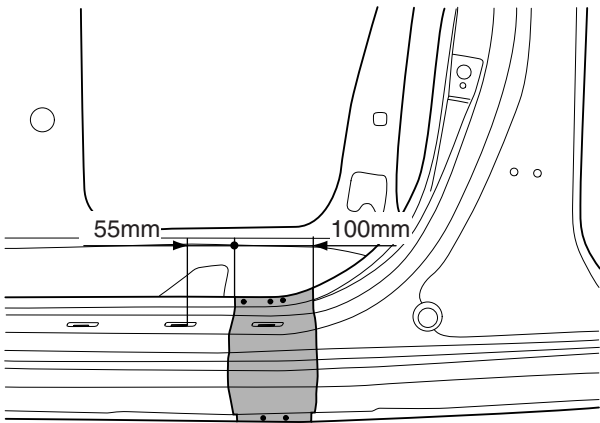

BHDBP6504

9. Cut front side sill outer panel at cutlines.



NOTE

When cutting front side sill outer panel, take care not to cut through mating flanges or side sill outer reinforcement.

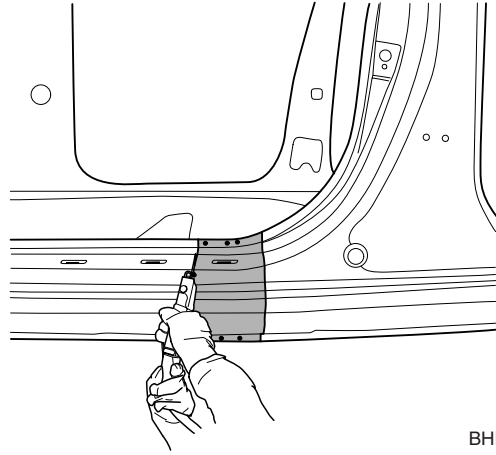

BHDBP6504A

10. Drill out all spotwelds (5) attaching the front side sill outer panel to the side sill assembly.

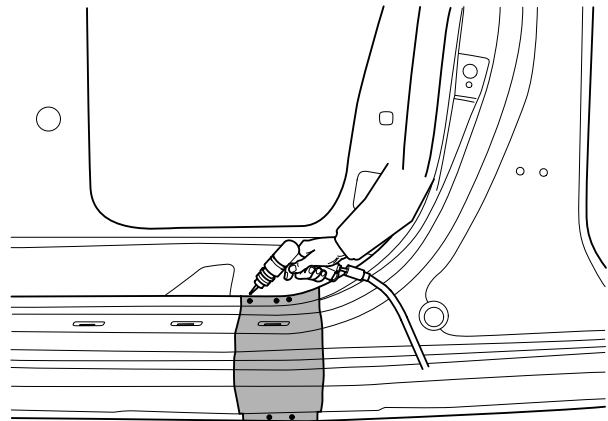

BHDBP6504B

11. Remove the front side sill outer panel.

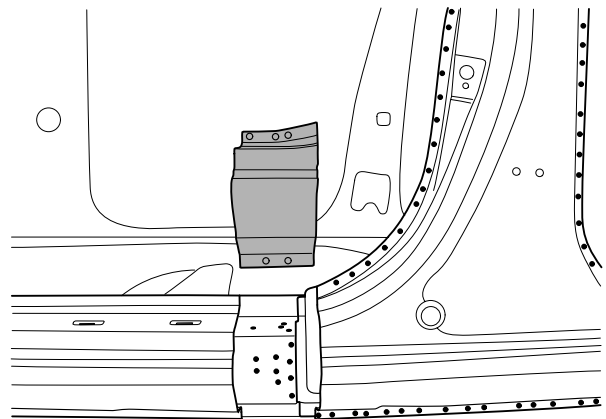

BHDBP6505

12. Drill out all spotwelds (20) attaching the front side sill outer reinforcement to the side sill inner panel.

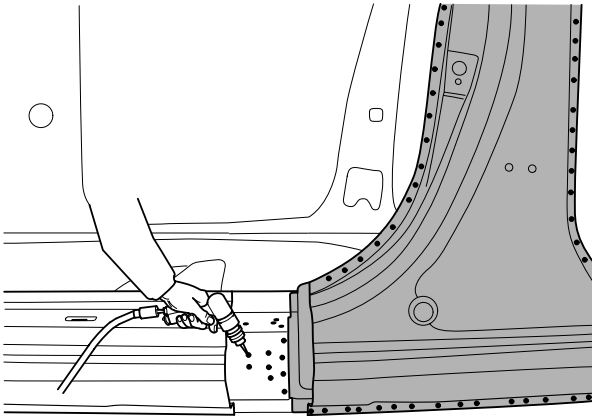

BHDBP6505A

15. Drill out all spotwelds (6) attaching the rear side sill outer panel to the side sill assembly.

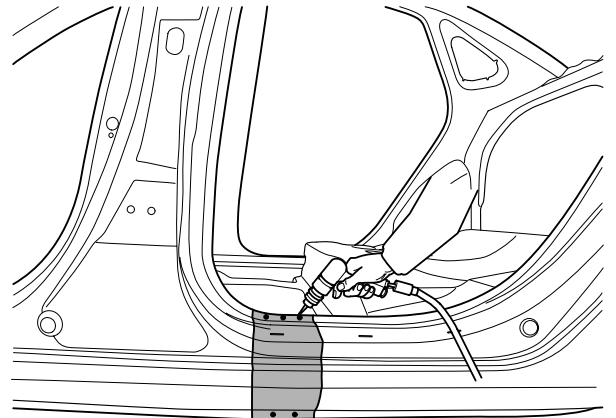

BHDBP6506C

13. Measure and mark the vertical cutlines on rear side sill outer panel 60mm and 160mm from the rear door step trim mounting hole.

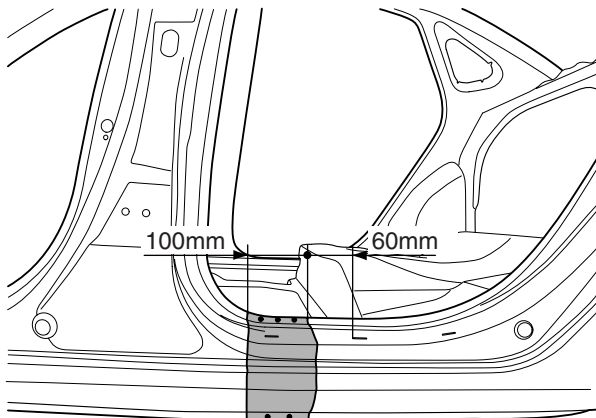

BHDBP6506A

16. Remove the rear side sill outer panel.

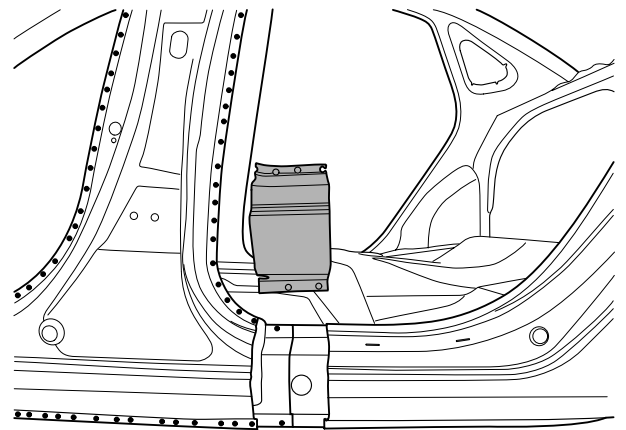

BHDBP6507

14. Cut rear side sill outer panel at cutlines.



NOTE

When cutting rear side sill outer panel, take care not to cut through mating flanges or side sill outer reinforcement.

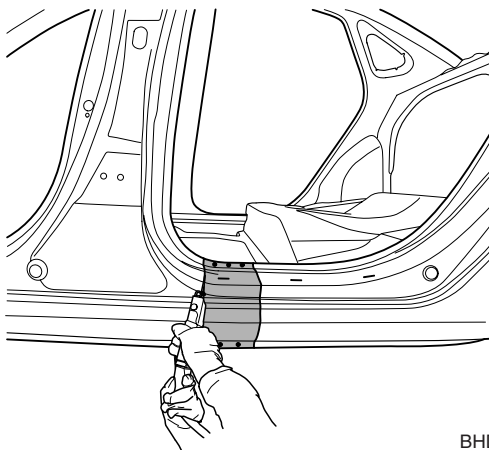

BHDBP6506B

17. Measure and mark the cutline on side sill outer reinforcement as indicated in the illustration.

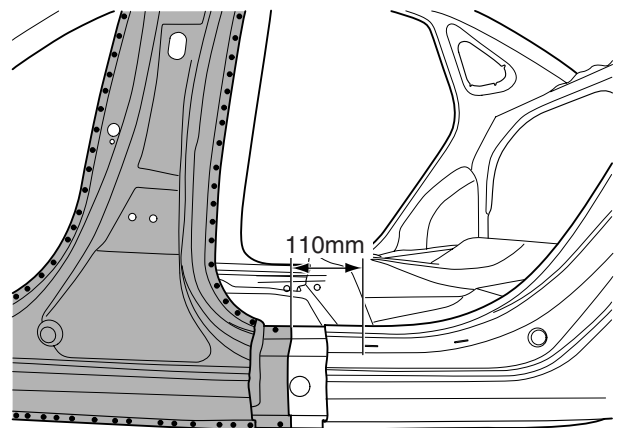

BHDBP6507A

18. Cut side sill outer reinforcement at cutline.

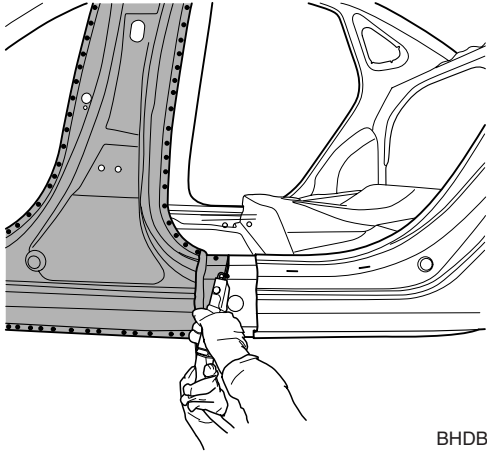

BHDBP6507B

19. Drill out all spotwelds (102) attaching the center pillar outer panel to center pillar and side sill assembly.

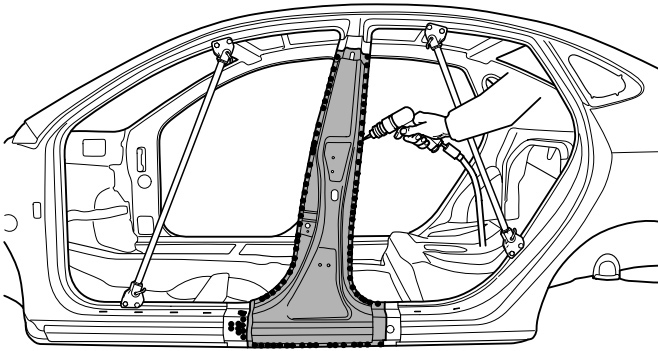

BHDBP6508

20. Drill out all spotwelds (4) attaching the center pillar outer panel to side sill inner panel.

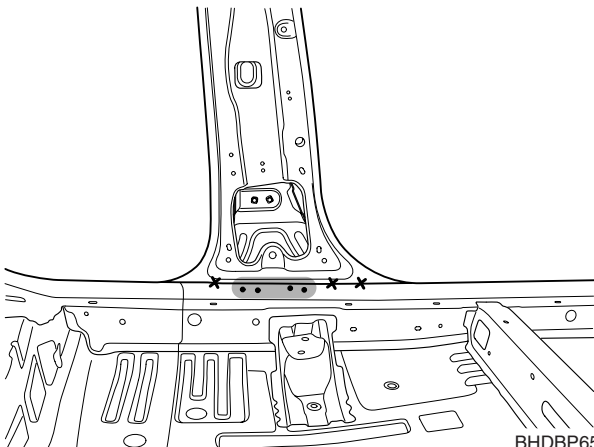

BHDBP6509

21. Remove the center pillar outer panel.

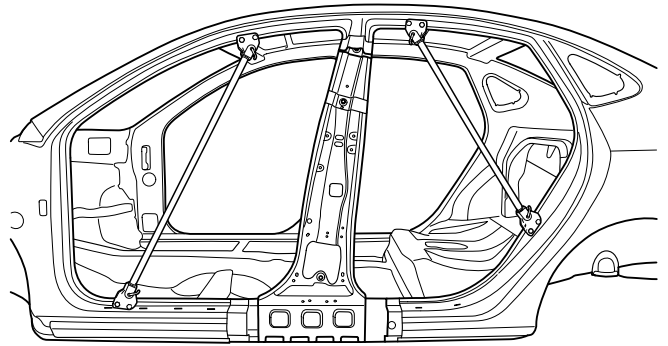

BHDBP6510

22. Measure and mark the horizontal cutline on center pillar inner panel as indicated in the illustration.

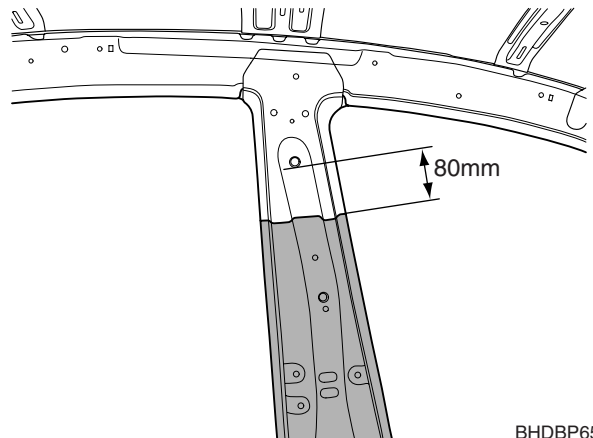

BHDBP6511

23. Cut through center pillar inner panel at cutline.

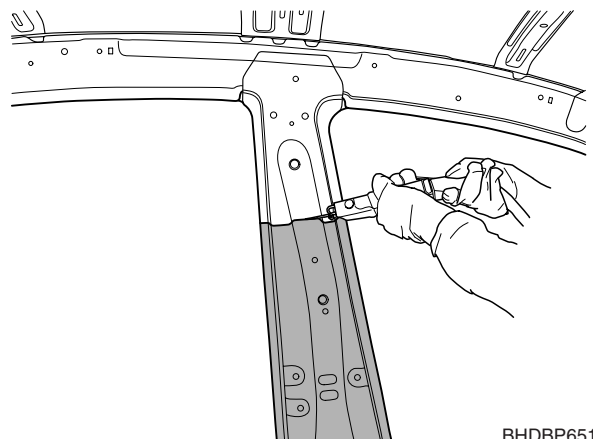

BHDBP6511A

24. Remove MIG lap welds (3) attaching the center pillar inner panel to side sill inner panel.

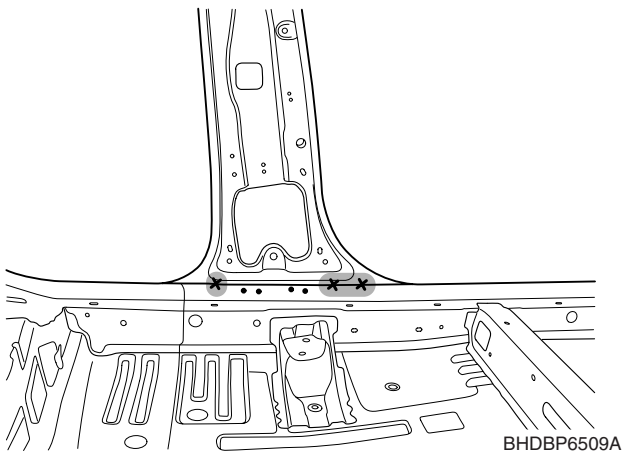

27. After removing, apply the welding primer.

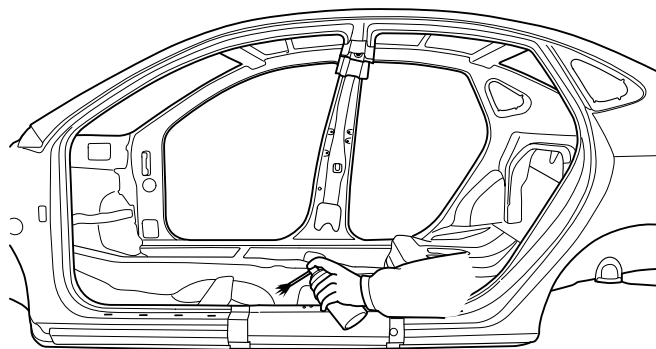

25. Remove the center pillar inner panel.

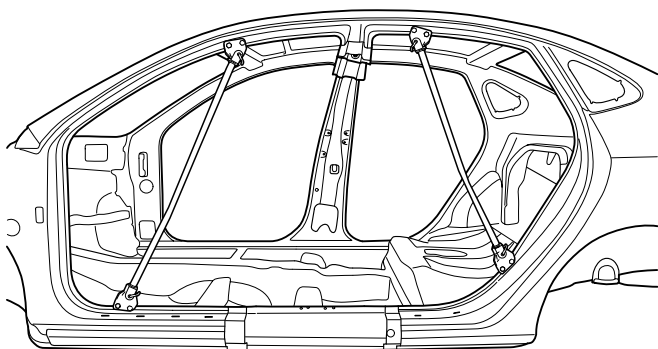

26. Prepare all surfaces to be welded.

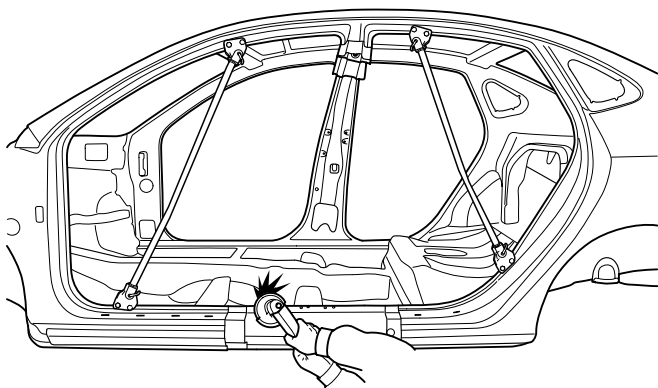

INSTALLATION

1. Transfer the cutline dimensions to the new center pillar inner panel, adding 30mm overlap the end and cut to length.

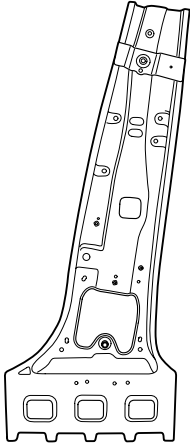

BHDBP6514

2. Fit and clamp the new center pillar inner panel in place for welding.
3. Measure and each measurement point (Refer to the BODY DIMENSIONS) and correct the installation position.

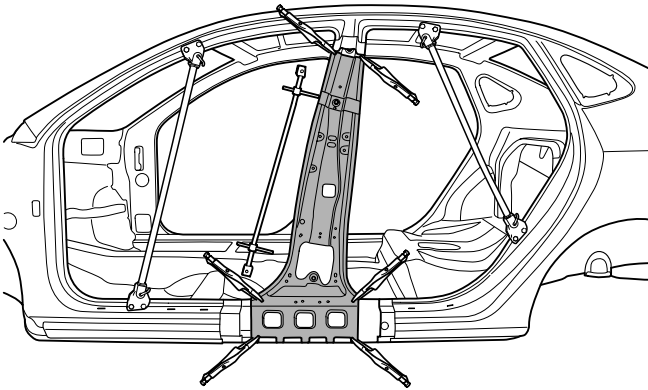

BHDBP6510A

4. MIG lap welds and MIG butt weld seams.

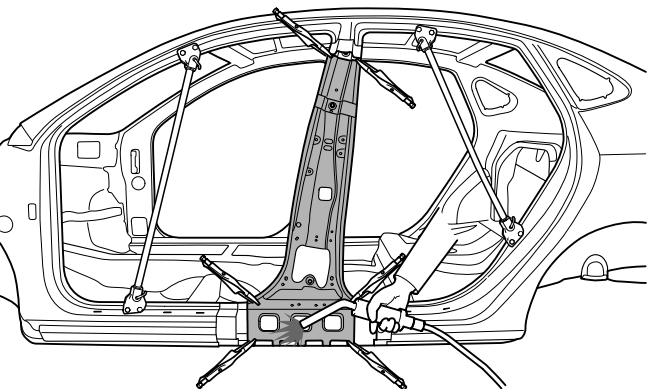

BHDBP6510B

5. Clean and prepare all welds, and remove all residue.

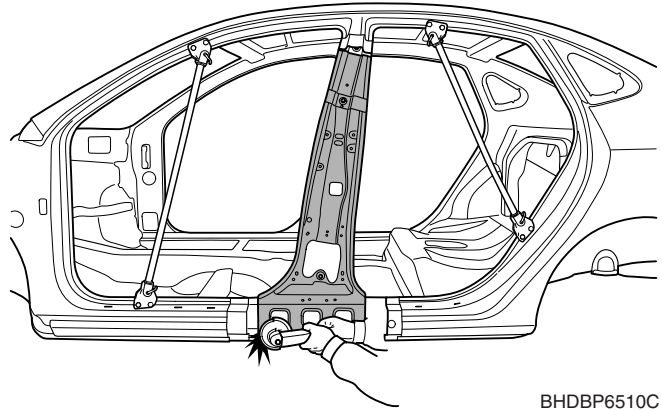

BHDBP6510C

6. After removing, apply the welding primer.

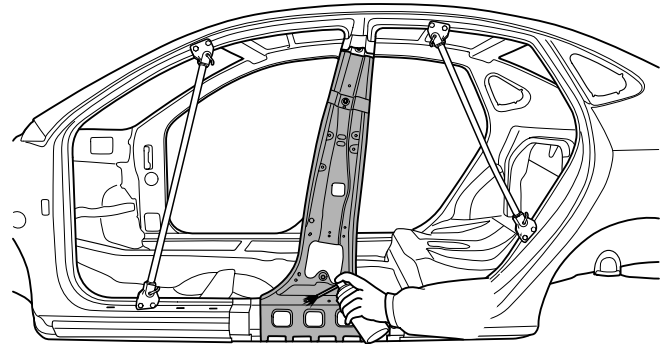

BHDBP6510D

7. Transfer the cutline dimensions to the new side outer panel, adding 30mm overlap to each end and cut to length.
8. Drill 6mm holes in overlap areas and along center pillar outer panel flanges.

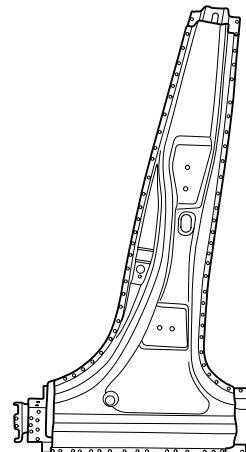

BHDBP6515

9. Fit and clamp the new center pillar outer panel in place for welding.
10. Measure and each measurement point (Refer to the BODY DIMENSIONS) and correct the installation position.

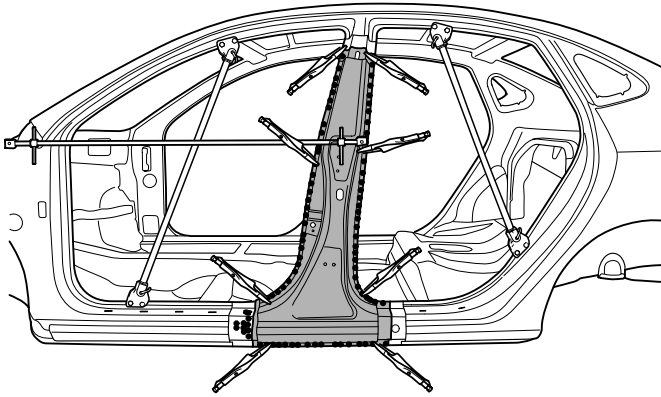

BHDBP6508A

11. Check the fit of the front and rear doors.
12. Reinstall center pillar outer panel.
13. Apply body filler to the outer center pillar seam. Sand and finish.
14. MIG plug weld all holes and MIG butt weld seams.

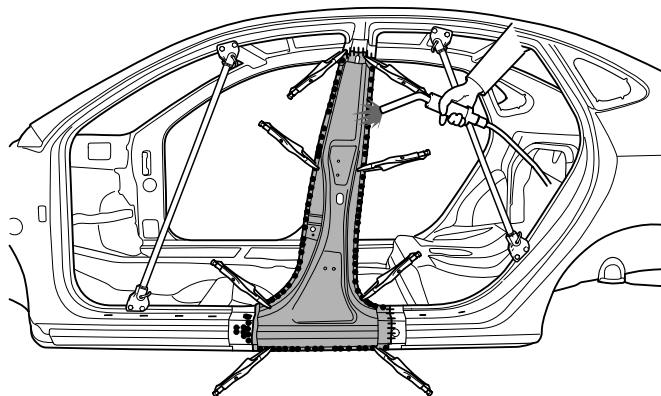

BHDBP6508B

15. Clean and prepare all welds, and remove all residue.

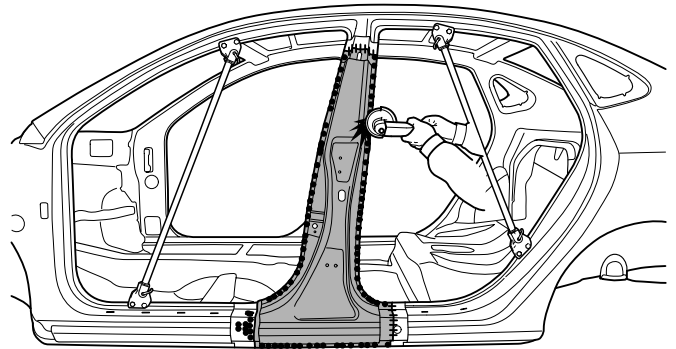

BHDBP6508C

16. After removing, apply the welding primer.

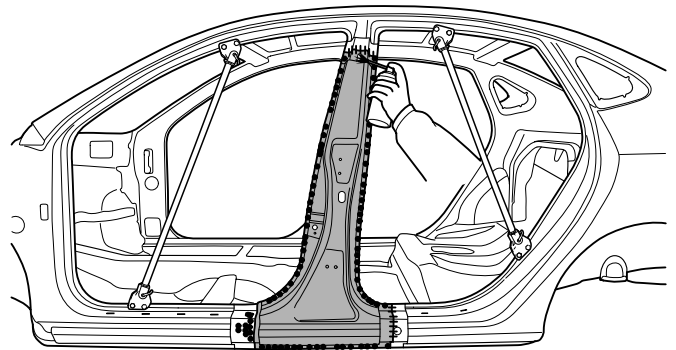

BHDBP6508D

17. Reattach the cut away center pillar outer panel section, then MIG plug weld all holes and MIG butt weld.

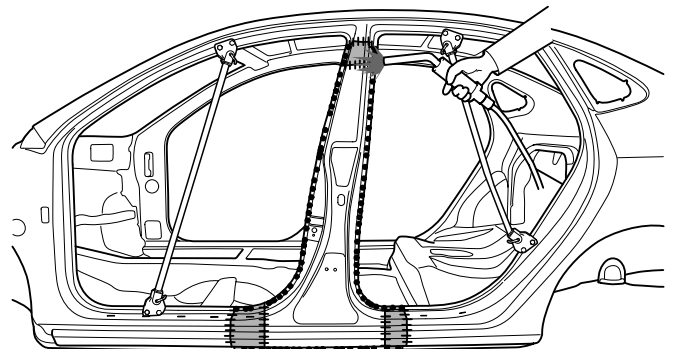

BHDBP6501A

18. Clean all welds with a disc grinder.

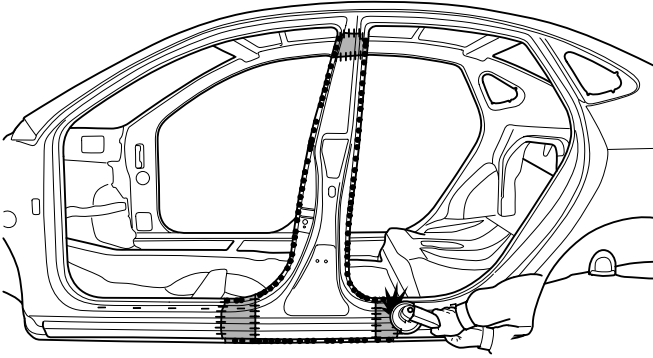

BHDBP6501B

19. Apply the two-part epoxy primer to the interior of the center pillar.
20. Apply an anti-corrosion agent to the welded parts and interior of the center pillar (Refer to the CORROSION PROTECTION).

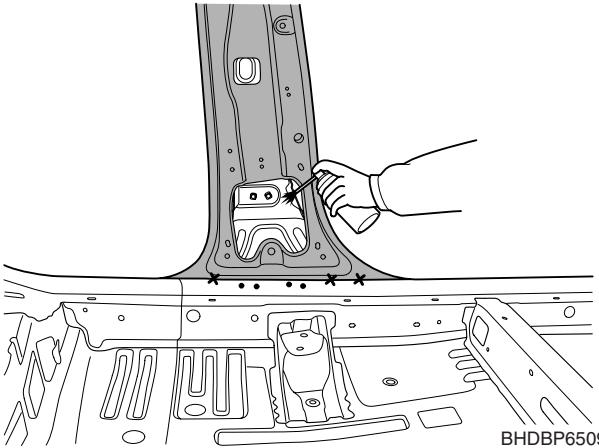

BHDBP6509B

21. Prepare exterior surfaces for priming, using wax and grease remover.
22. Apply metal conditioner and water rinse.
23. Apply conversion coating and water rinse.
24. Apply the two-part epoxy primer.
25. Apply the correct seam sealer to all joints carefully (Refer to the BODY SEALING LOCATIONS).

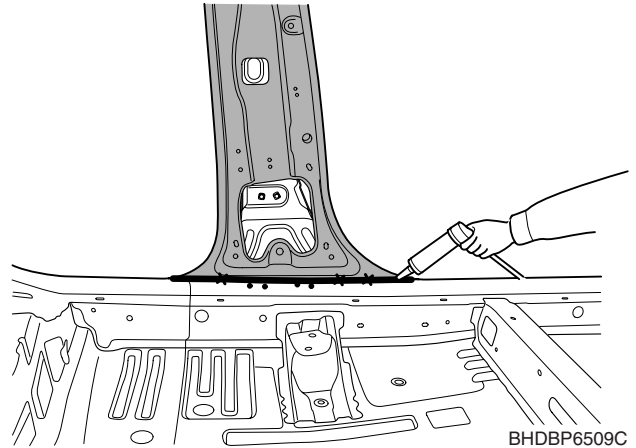

BHDBP6509C

QUARTER PANEL

WELDING POINTS

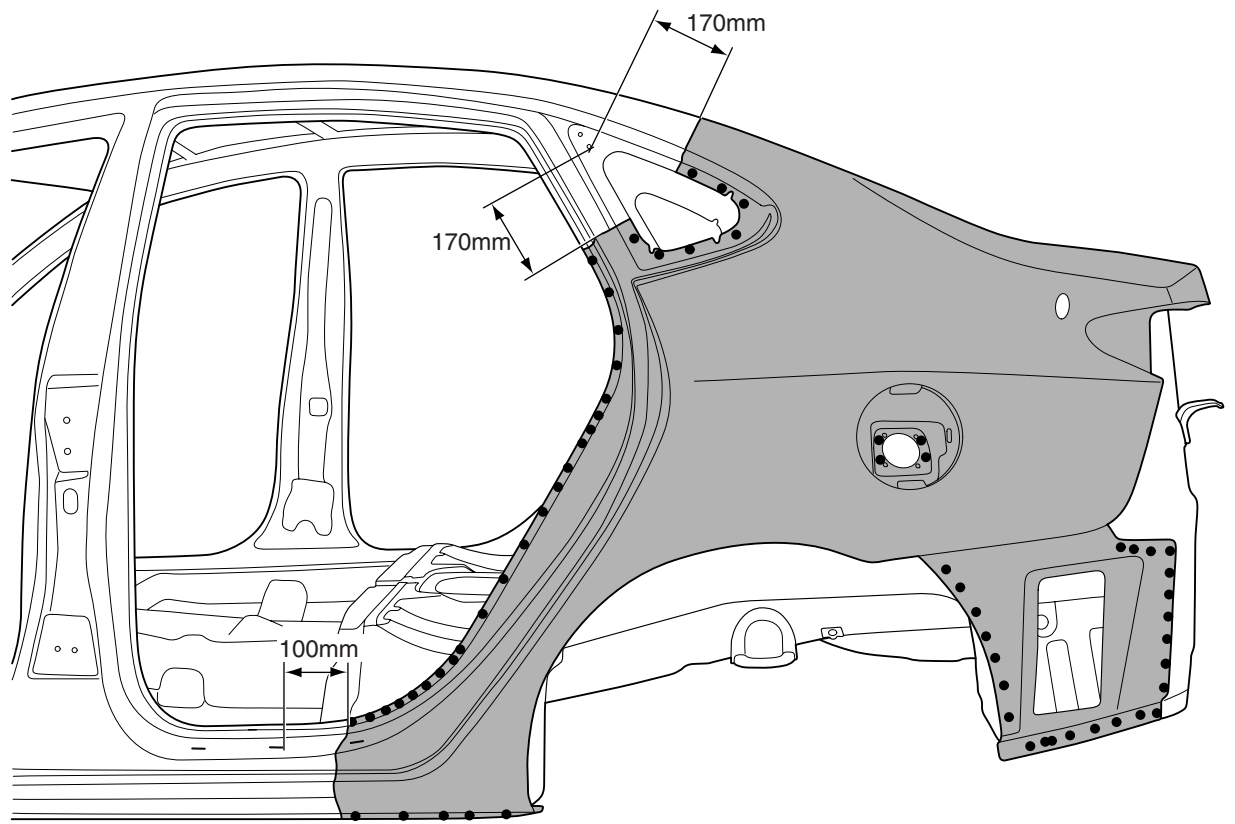

- MIG plug welding
- ≡≡≡ MIG butt welding
- ×× MIG lap welding

REMOVAL

1. Depending on the extent of damage, measure and mark cutlines on the quarter outer panel as indicated in the illustration.

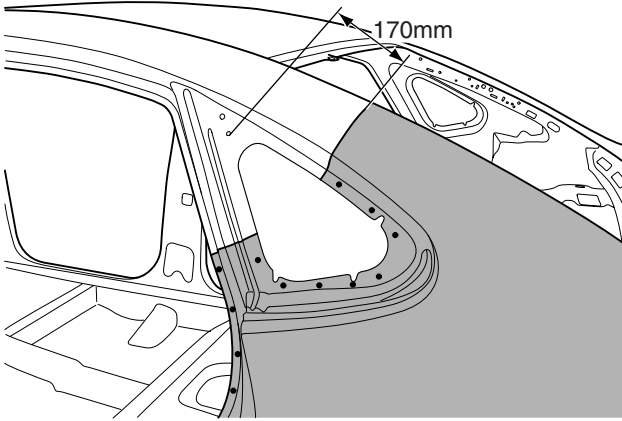

BHDBP6602

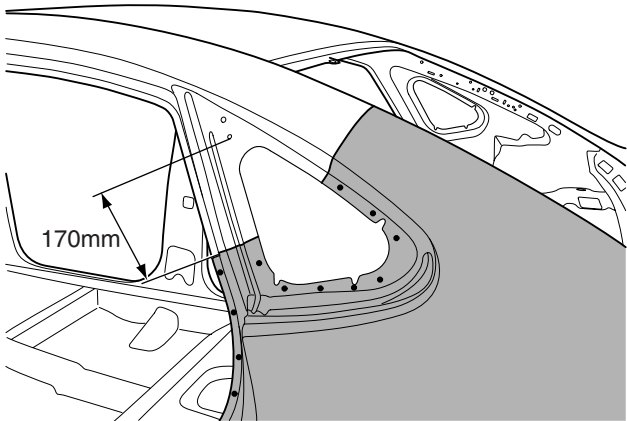

BHDBP6602A

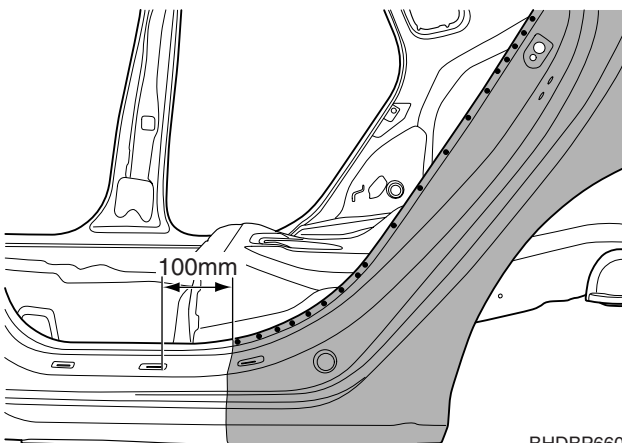

BHDBP6603

2. Cut the quarter outer panel at cutlines and remove the quarter outer panel as illustration.

**NOTE**

When cutting the quarter outer panel, be careful not to cut quarter inner panel.

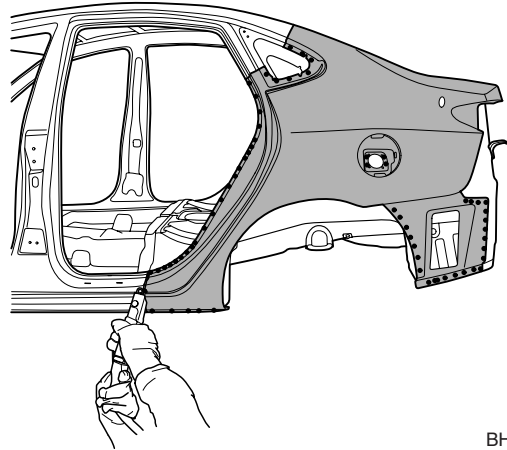

BHDBP6601A

3. Drill out all attaching spotwelds(95) on the quarter outer panel, including the seam around the door lip opening.

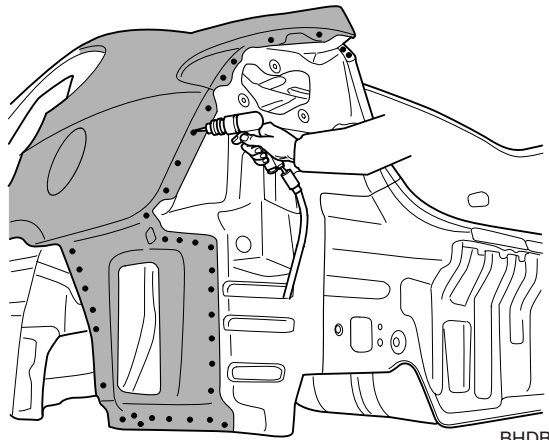

BHDBP6701

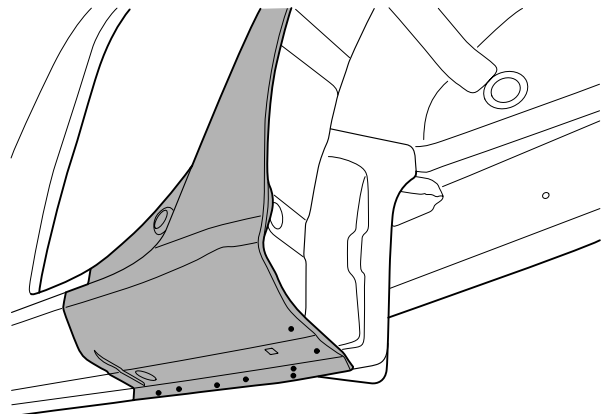

BHDBP6605

5. Remove the quarter outer panel.

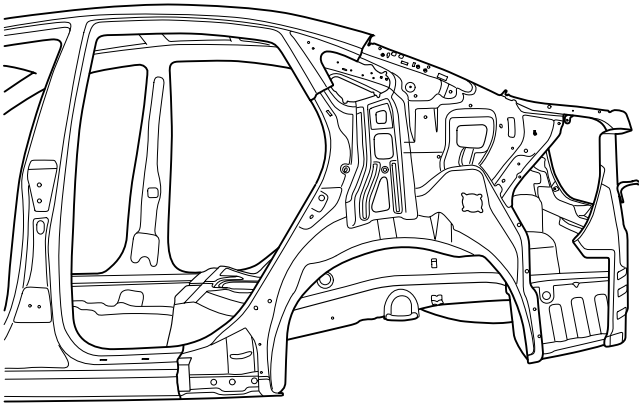

BHDBP6607

6. Clean cut portions with a disc grinder.

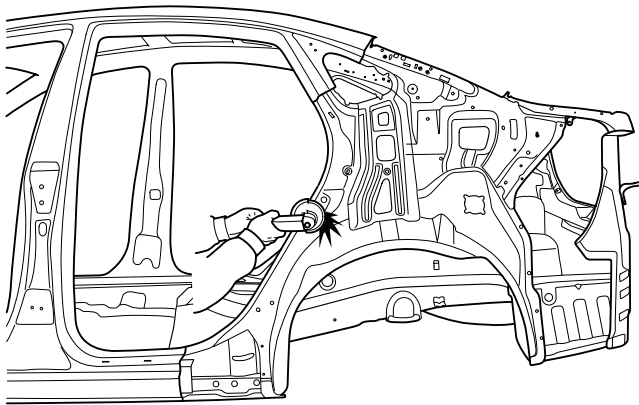

BHDBP6607A

7. After removing, apply the welding primer.

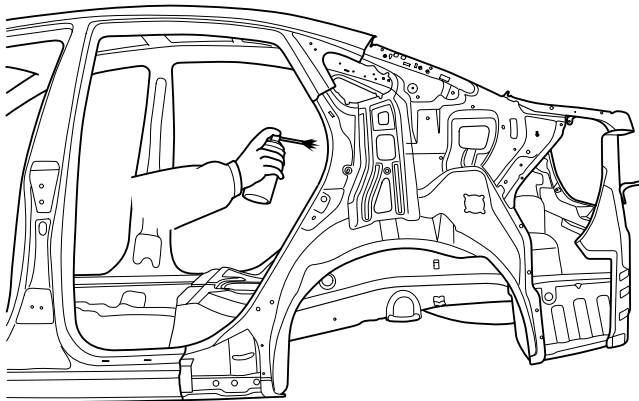

BHDBP6607B

8. Prepare all surfaces to be welded.

INSTALLATION

1. Transfer the cutline dimensions to the new quarter outer panel, adding 30 mm overlap each end.
2. Drill 6 mm holes in overlap areas and along upper and lower flanges of the new quarter outer panel for MIG plug welding.

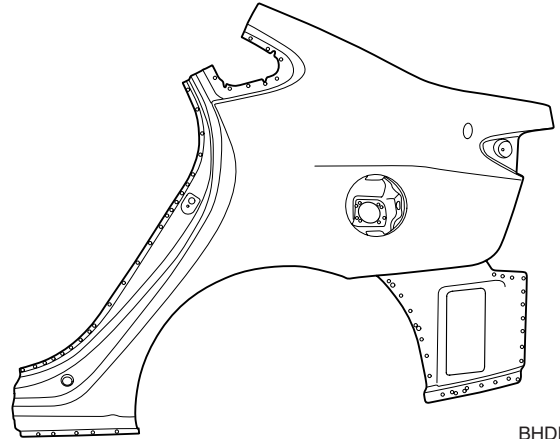

BHDBP6608

3. Apply body filler to the welded seam. Sand and finish. Apply the two-part epoxy primer to the interior of the quarter outer panel.
4. Fit and clamp the quarter outer panel in place.
5. Measure and each measurement point (Refer to the BODY DIMENSIONS) and correct the installation position.

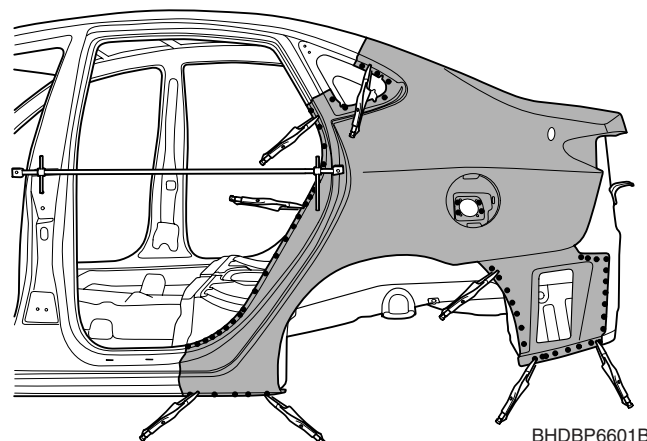

BHDBP6601B

6. MIG plug weld all holes and MIG butt weld seams.

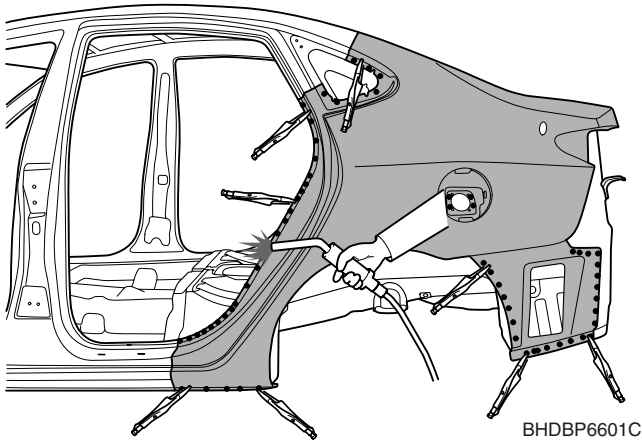

7. Clean and prepare all welds, remove all residue.

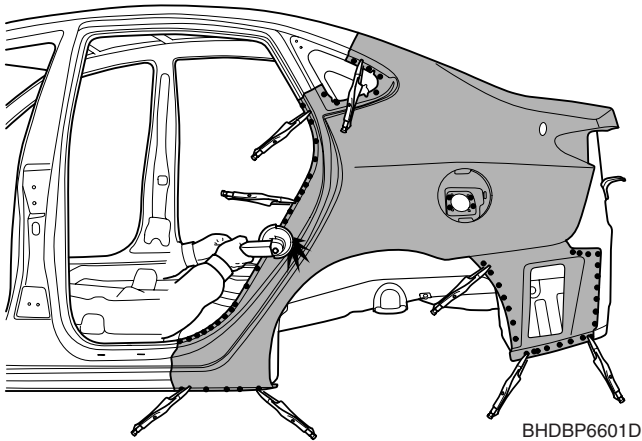

8. Apply an anti-corrosion agent to the welded parts and interior of the quarter outer panel (Refer to the CORROSION PROTECTION).
9. Prepare exterior surfaces for priming, using wax and grease remover.
10. Apply metal conditioner and water rinse.
11. Apply conversion coating and water rinse.
12. Apply the two-part epoxy primer.

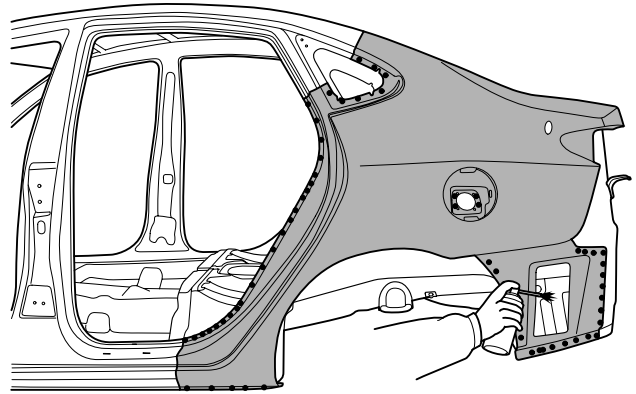

13. Apply the correct seam sealers to all joints.
14. Reprime over the seam sealer to complete the repair.

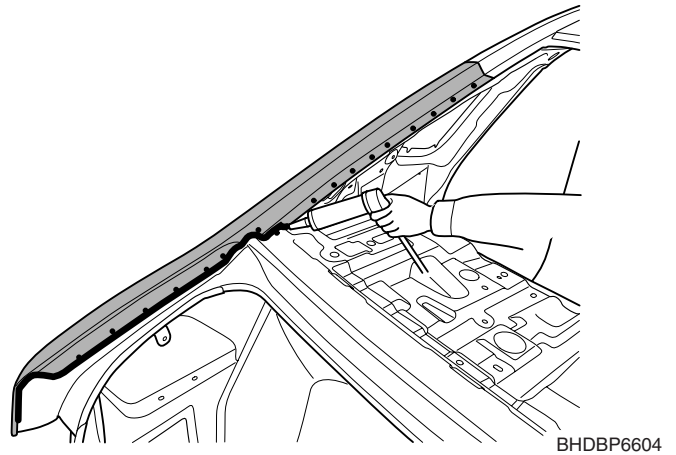

15. In order to improve corrosion resistance, if necessary, apply an under body anti-corrosion agent to the wheel well (Refer to the CORROSION PROTECTION).

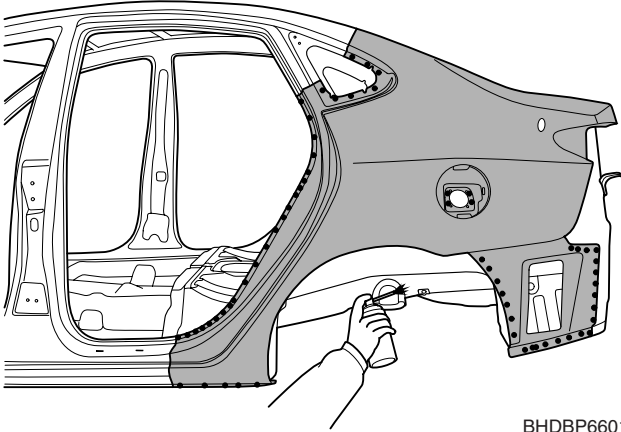

BHDBP6601F

BACK COMPLETE PANEL ASSEMBLY AND REAR FLOOR SIDE MEMBER

WELDING POINTS

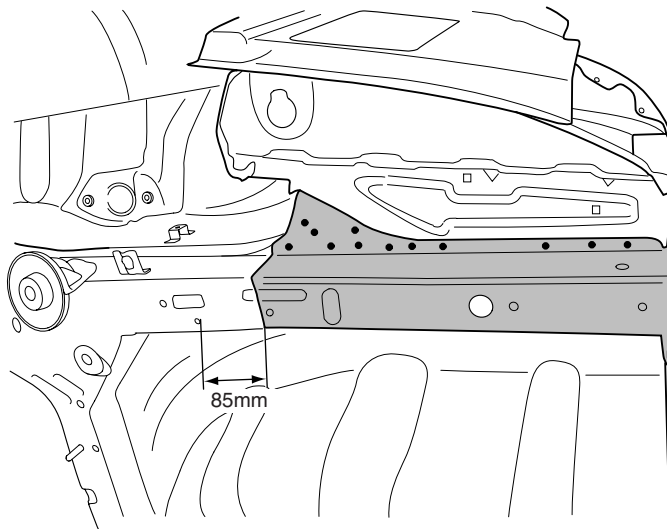
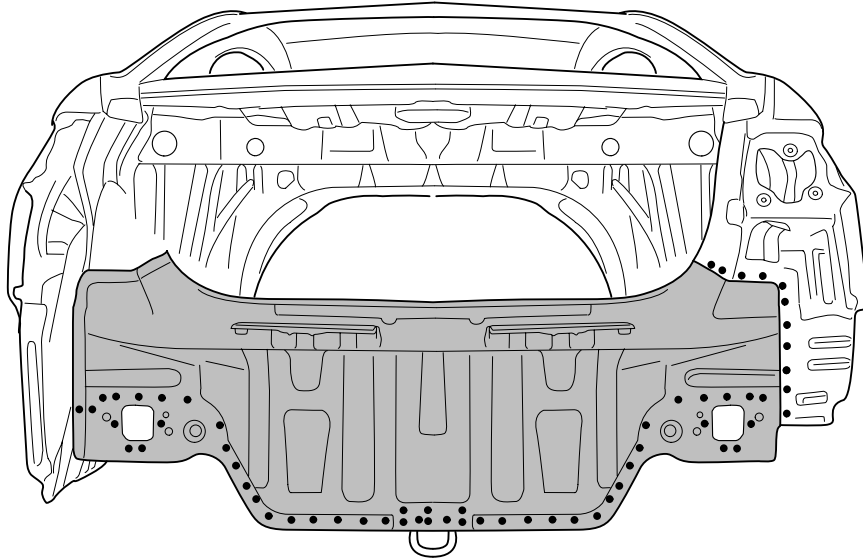

- MIG plug welding
- ≡≡≡ MIG butt welding
- ××× MIG lap welding

REMOVAL

 **NOTE**

Because the rear floor side members are designed to absorb energy during a rear collision, care must be used when deciding to use this repair method. This repair is recommended only for moderate damage to the vehicle, where distortions do not extend forward of the trunk region. If the damage is more severe, then the entire side member assembly should be replaced at the factory seams without employing this sectioning procedure.

The following procedure applies when only one rear floor side member needs to be replaced. If both side members are damaged and need to be replaced, then the procedure of rear floor side members and rear floor section should be followed.

Refer to the body dimension charts and measure the vehicle to determine straightening and alignment requirements.

The body must be returned to its original dimensions before beginning the repair procedure.

1. Drill out all the spotwelds(59) attaching the back complete panel assembly.

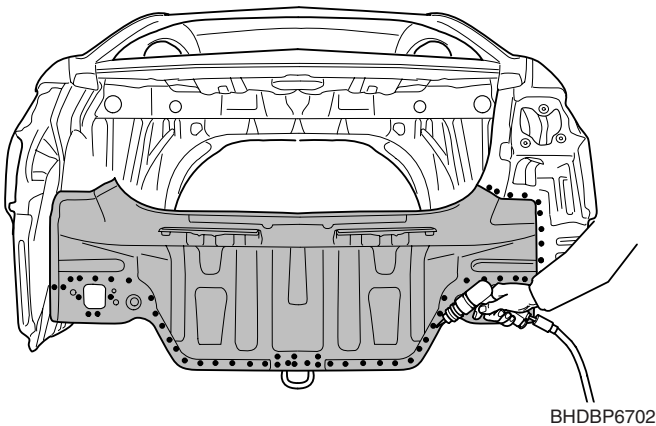

2. Remove the back complete panel assembly.

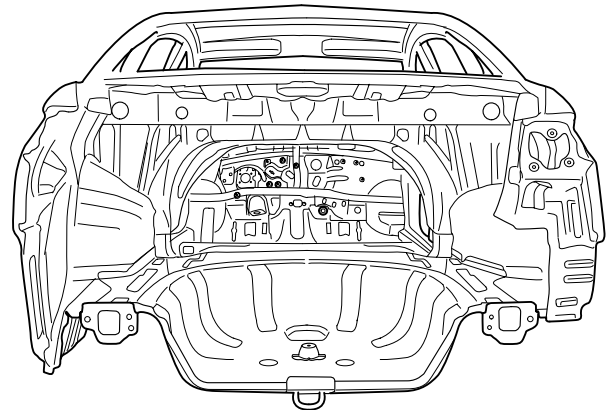

3. Depending on the extent of damage, measure and mark cutline on the rear floor side member as indicated in the illustration.

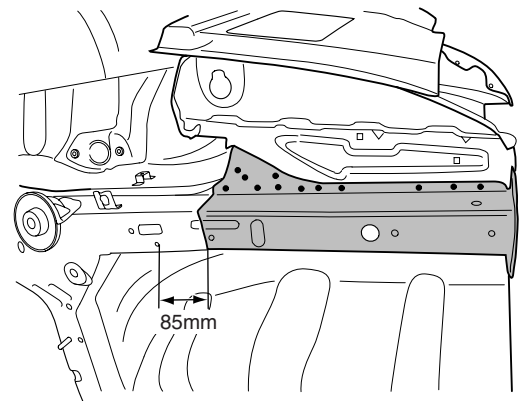

4. Cut rear floor side member along the cutline.

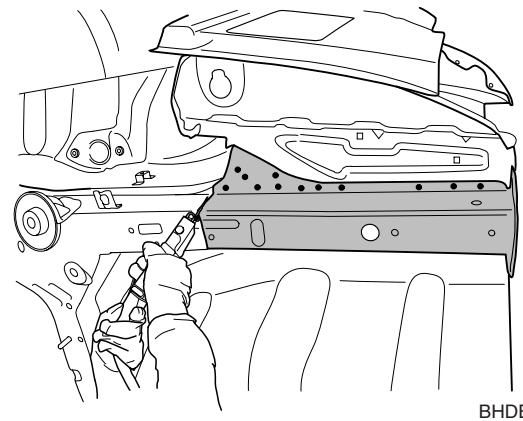

5. Drill out all attaching spotwelds(29) on the rear floor side member.

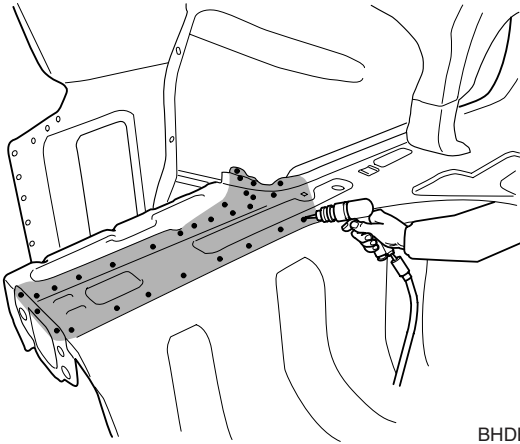

BHDBP6705

6. Remove the rear floor side member.

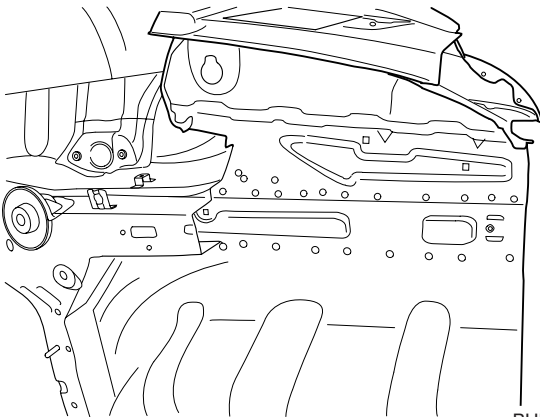

BHDBP6706

7. Clean cut portions with a disc grinder.

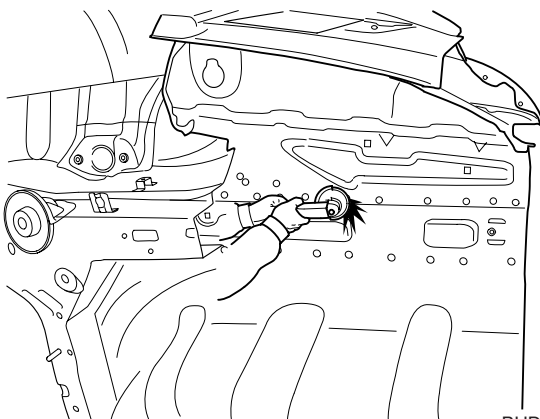

BHDBP6706A

8. After removing, apply the welding primer.

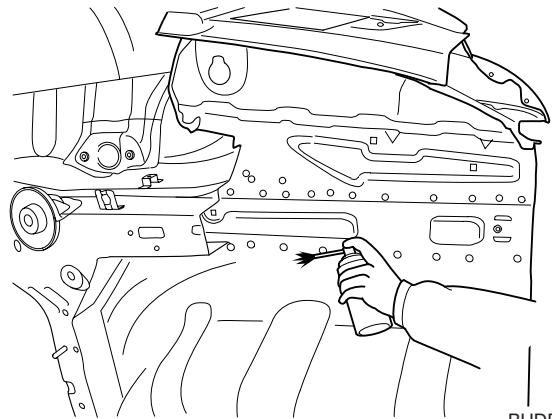

BHDBP6706B

9. Prepare all surfaces to be welded.

INSTALLATION

1. Transfer the cutline dimensions to the new rear floor side member, adding 30 mm overlap to the rear end.
2. Drill 6 mm holes in new rear floor side member for MIG plug welding.

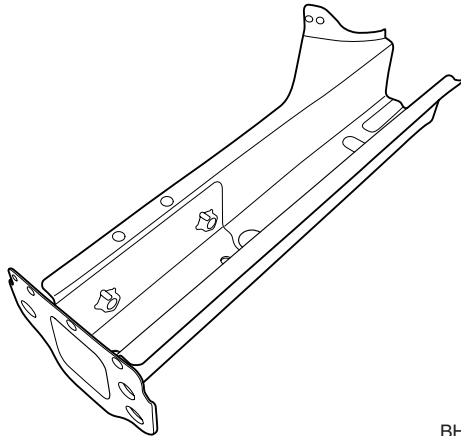

BHDBP6707

3. Fit and clamp the rear floor side member in place.
4. Measure and each measurement point (Refer to the BODY DIMENSIONS) and correct the installation position.

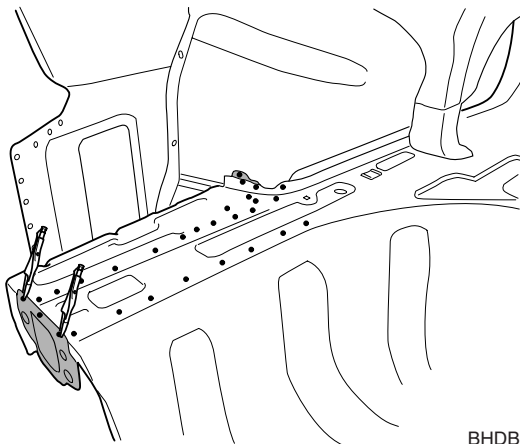

BHDBP6705A

5. MIG plug weld all holes and MIG butt weld seams.

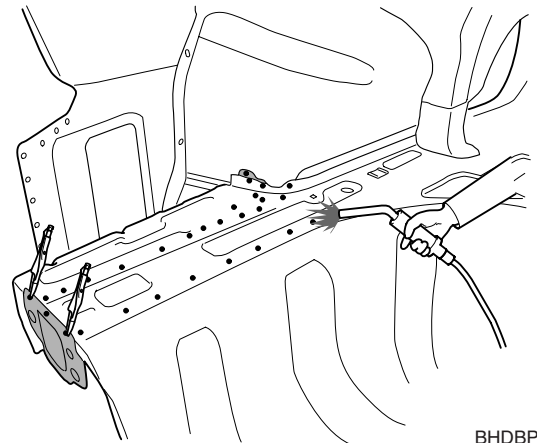

BHDBP6705B

6. Clean and prepare all welds, remove all residue.

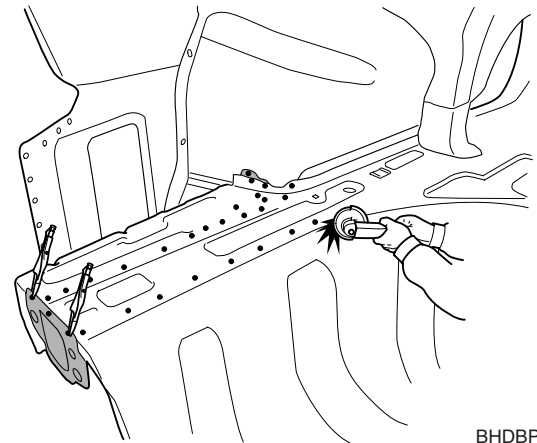

BHDBP6705C

7. After removing, apply the welding primer.

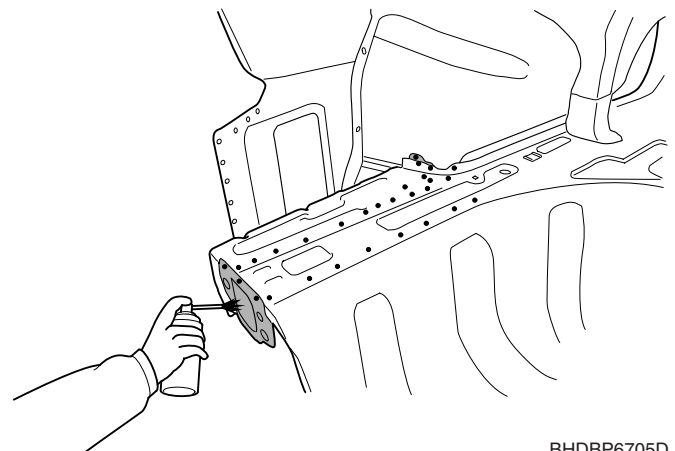

BHDBP6705D

8. Fit and clamp the new back complete panel assembly in place.
9. Measure and each measurement point (Refer to the BODY DIMENSIONS) and correct the installation position.

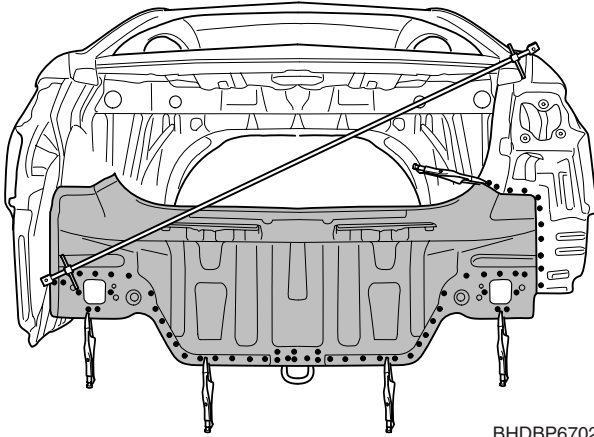

BHDBP6702A

10. MIG plug weld all holes.

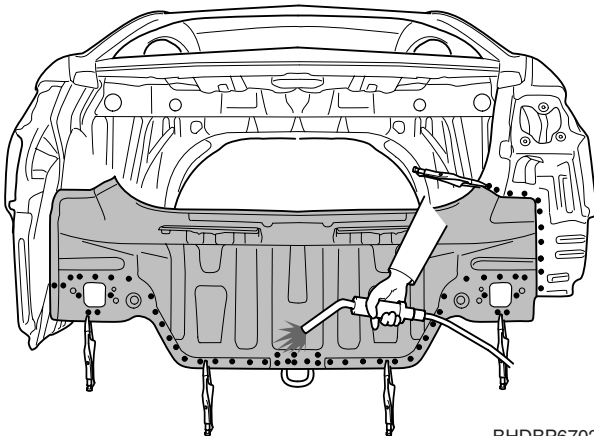

BHDBP6702B

11. Clean and prepare all welds, and remove all residue.

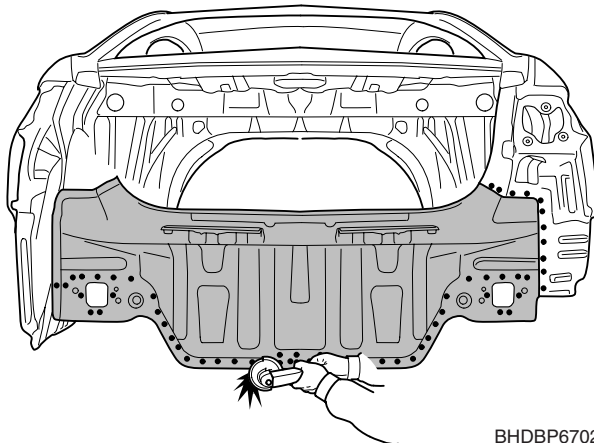

BHDBP6702C

12. Apply the two-part epoxy primer to the interior of the rear floor side member.

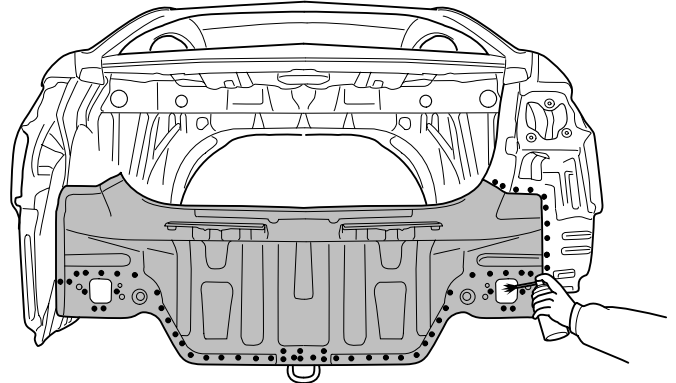

BHDBP6702D

13. Apply an anti-corrosion to the interior of the rear floor side member (Refer to the CORROSION PROTECTION).
14. Prepare exterior surfaces for priming, using wax and grease remover.
15. Apply metal conditioner and water rinse.
16. Apply conversion coating and water rinse.
17. Apply the two-part epoxy primer.

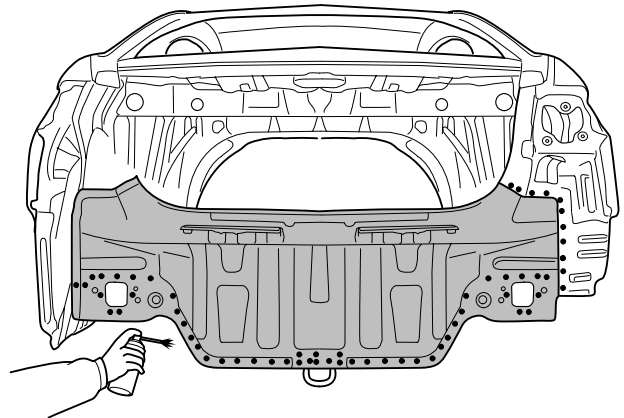

BHDBP6702E

18. Apply the correct seam sealer to all joints (Refer to the BODY SEALING LOCATIONS).

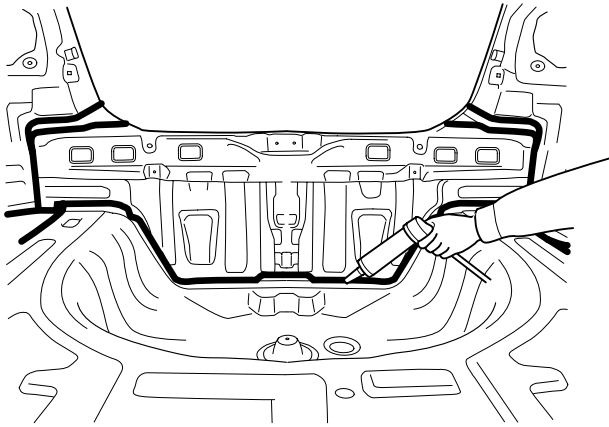

BHDBS6113

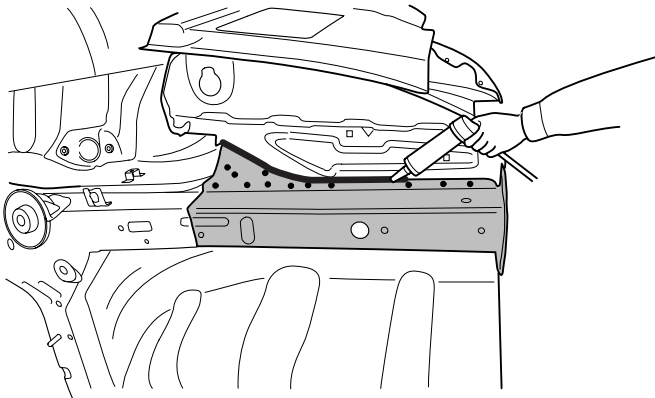

BHDBP6704C

19. Reprime over the seam sealer to complete the repair.
20. After completing body repairs, carefully apply under coating to the under body (Refer to the CORROSION PROTECTION).
21. In order to improve corrosion resistance, if necessary, apply an under body anti-corrosion agent to the panel which is repaired or replaced (Refer to the CORROSION PROTECTION).

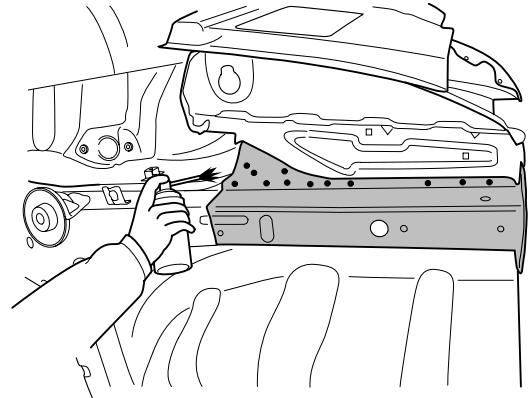

BHDBP6704D

BODY SEALING LOCATIONS

FLOOR

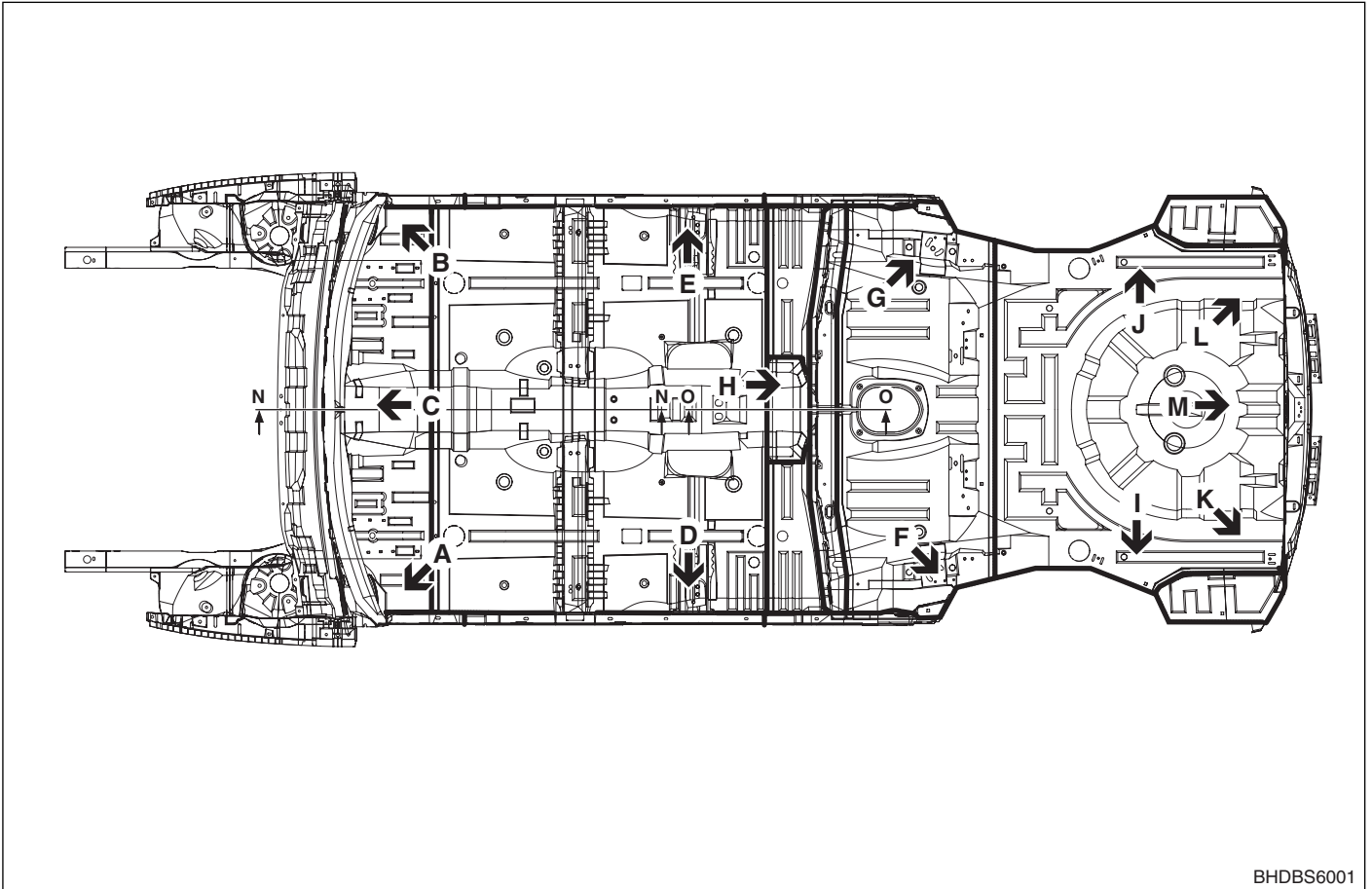

BHDBS6001

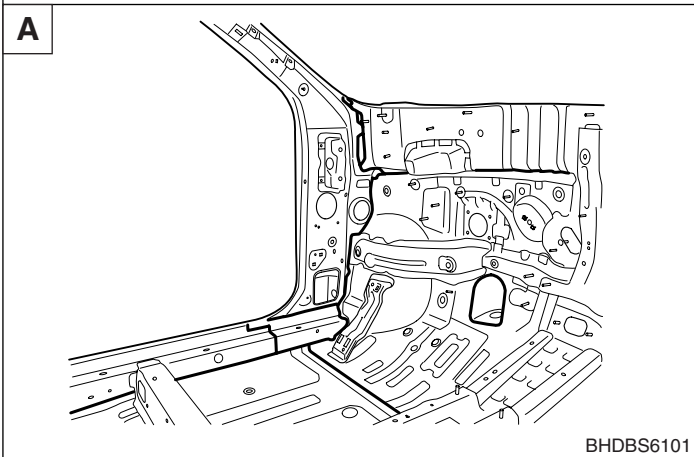

BHDBS6101

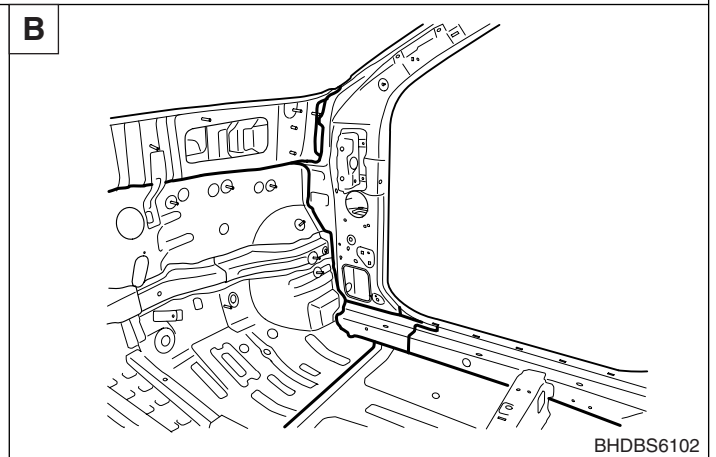

BHDBS6102

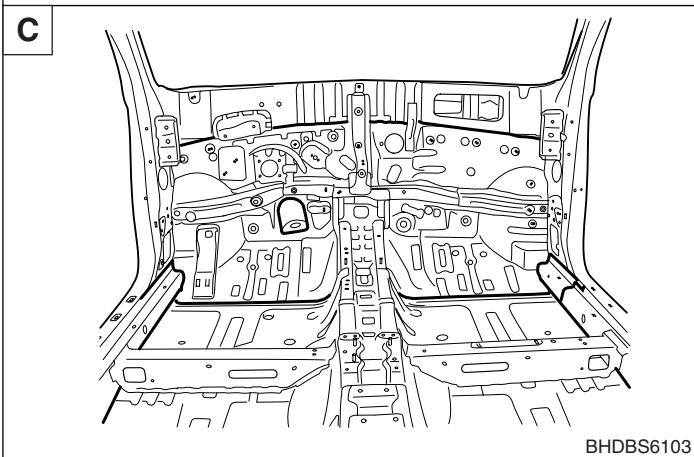

BHDBS6103

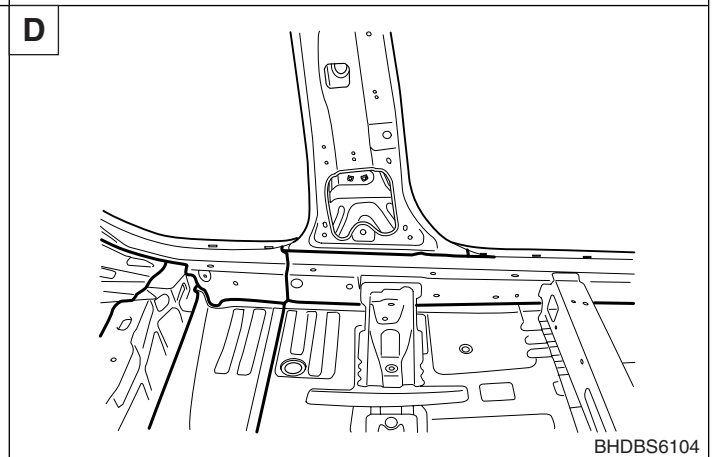

BHDBS6104

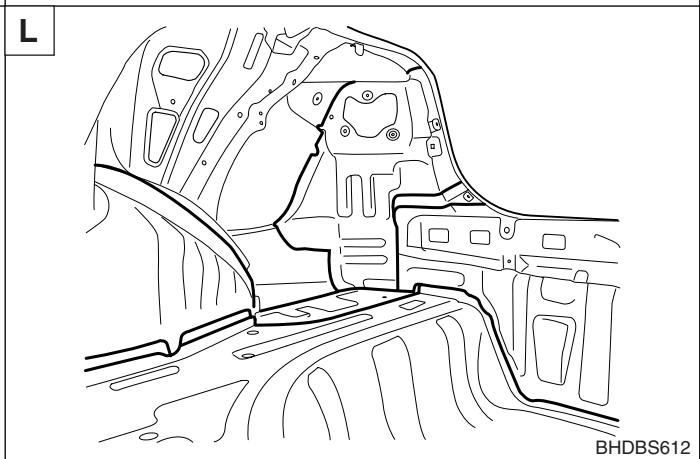
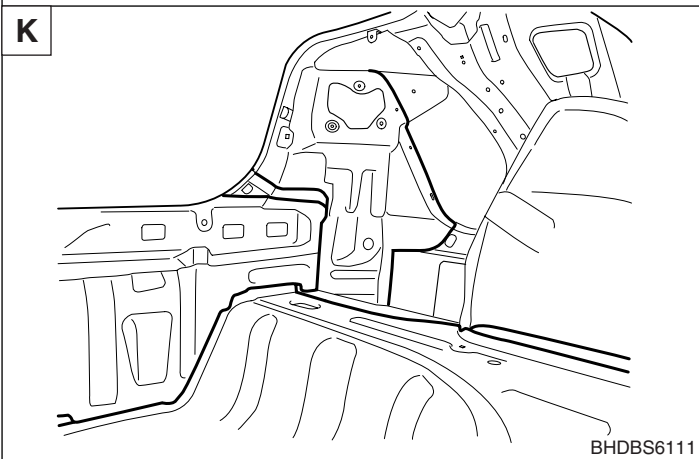
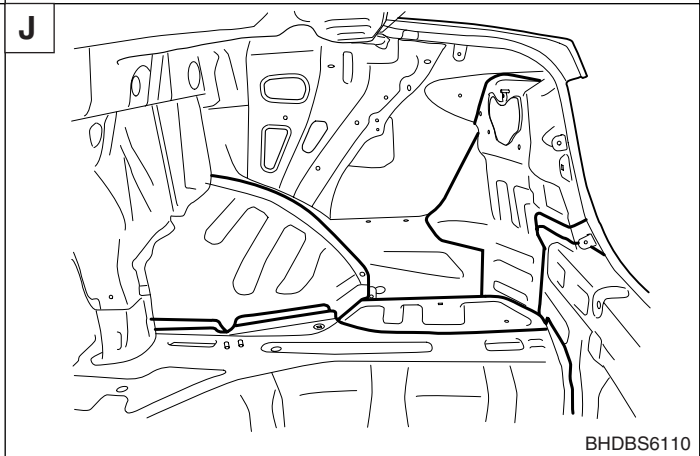
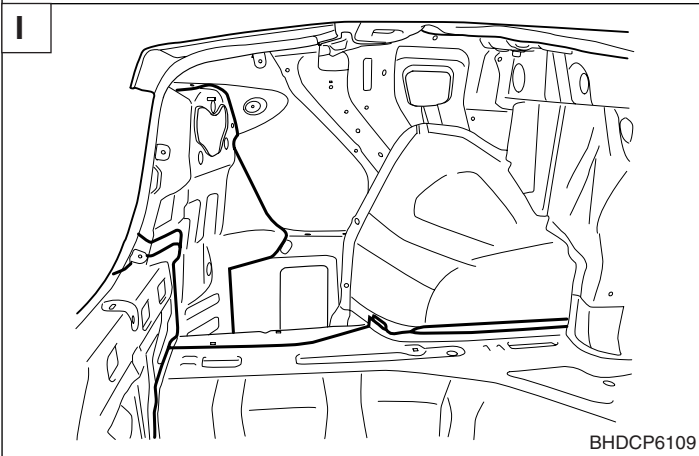
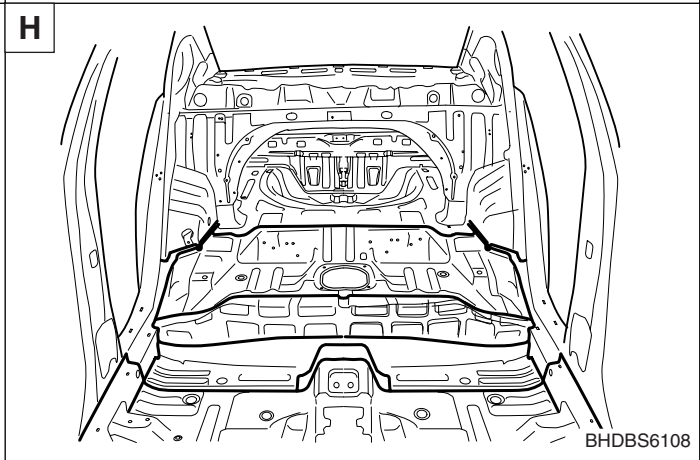
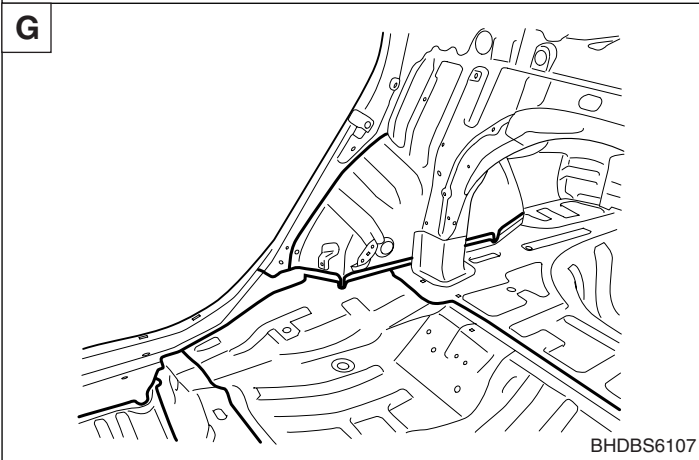
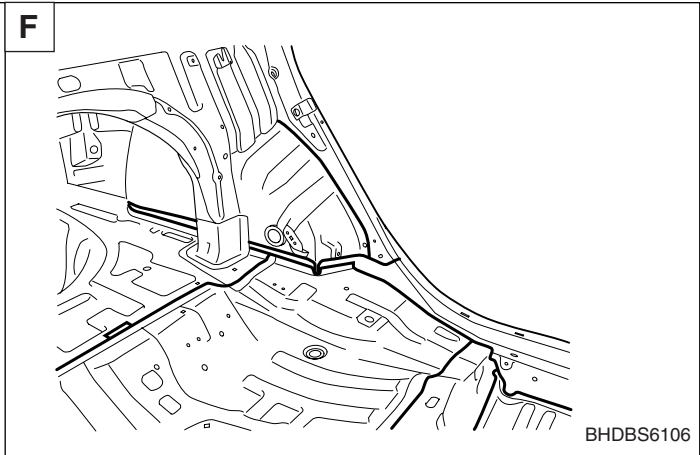
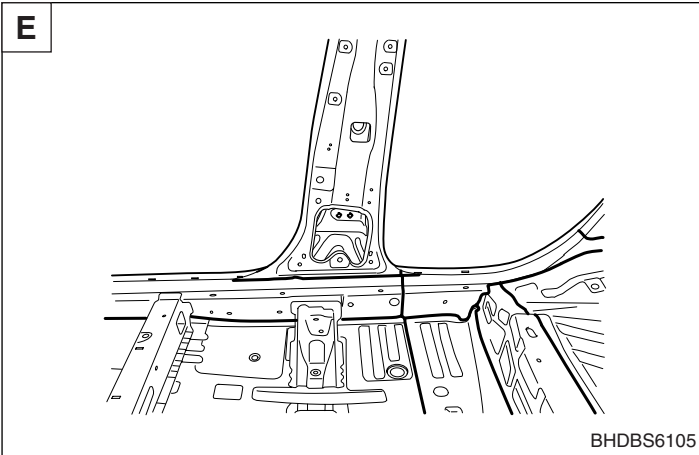

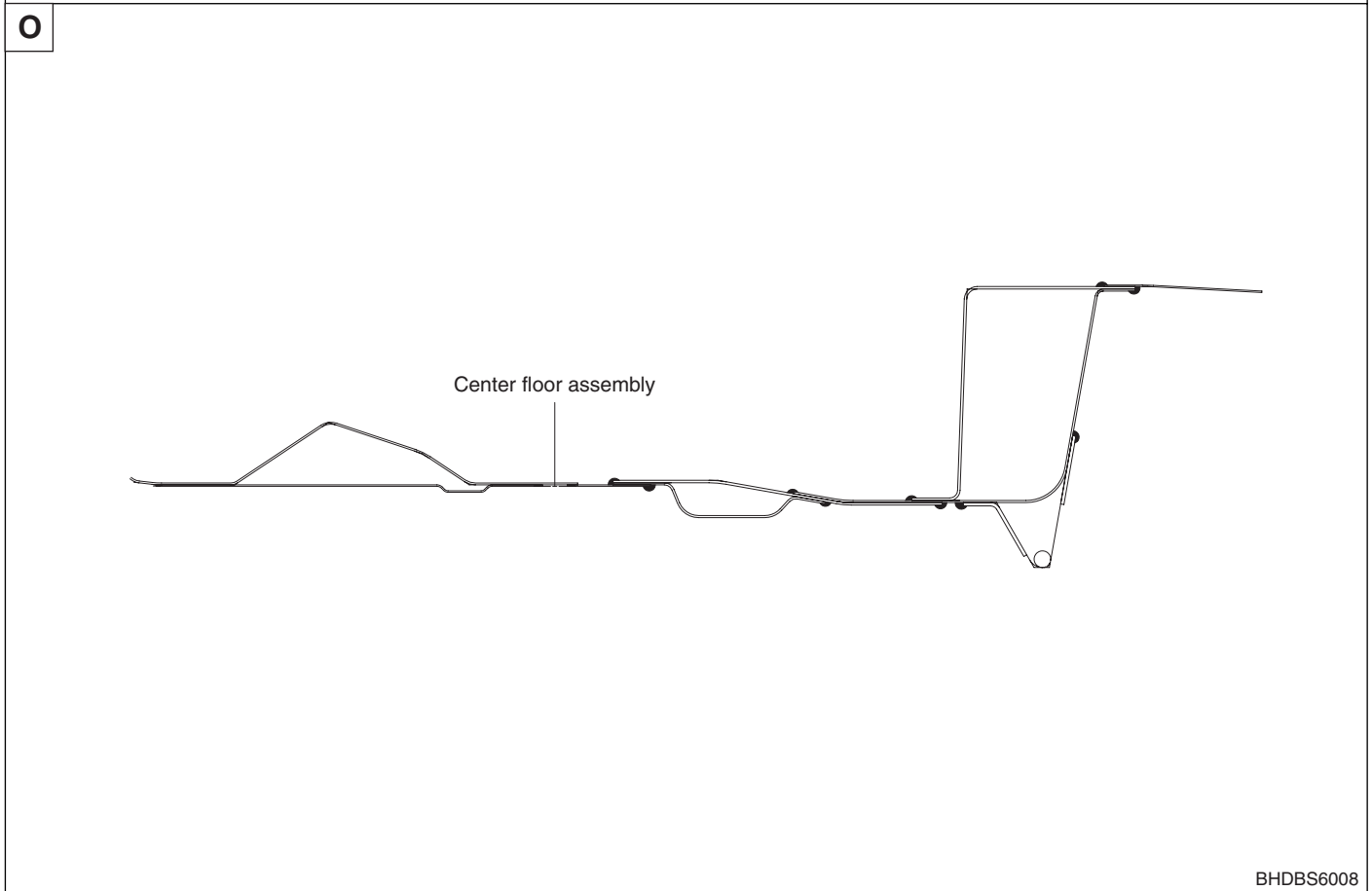
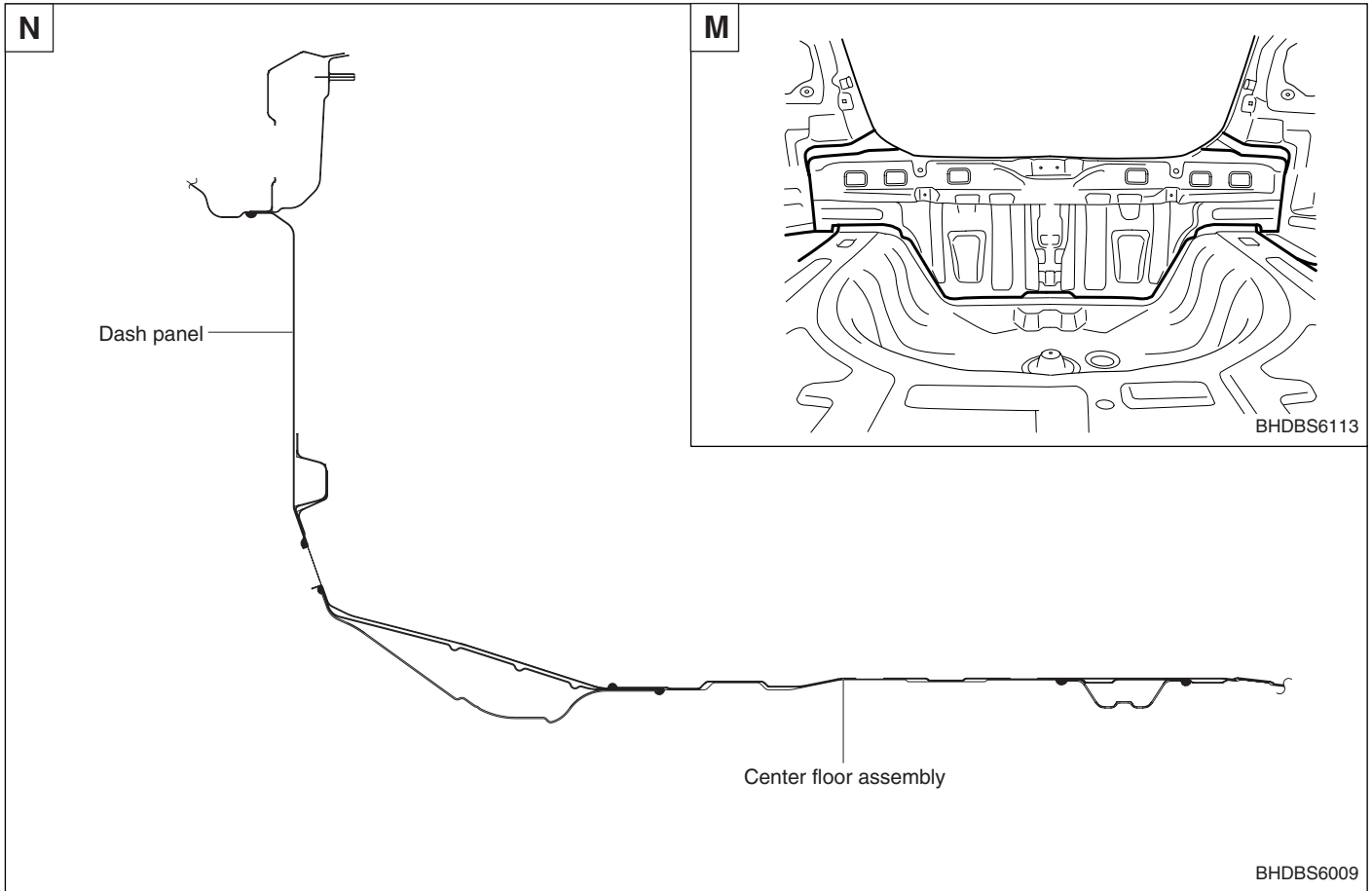

UPPER AND SIDE BODY

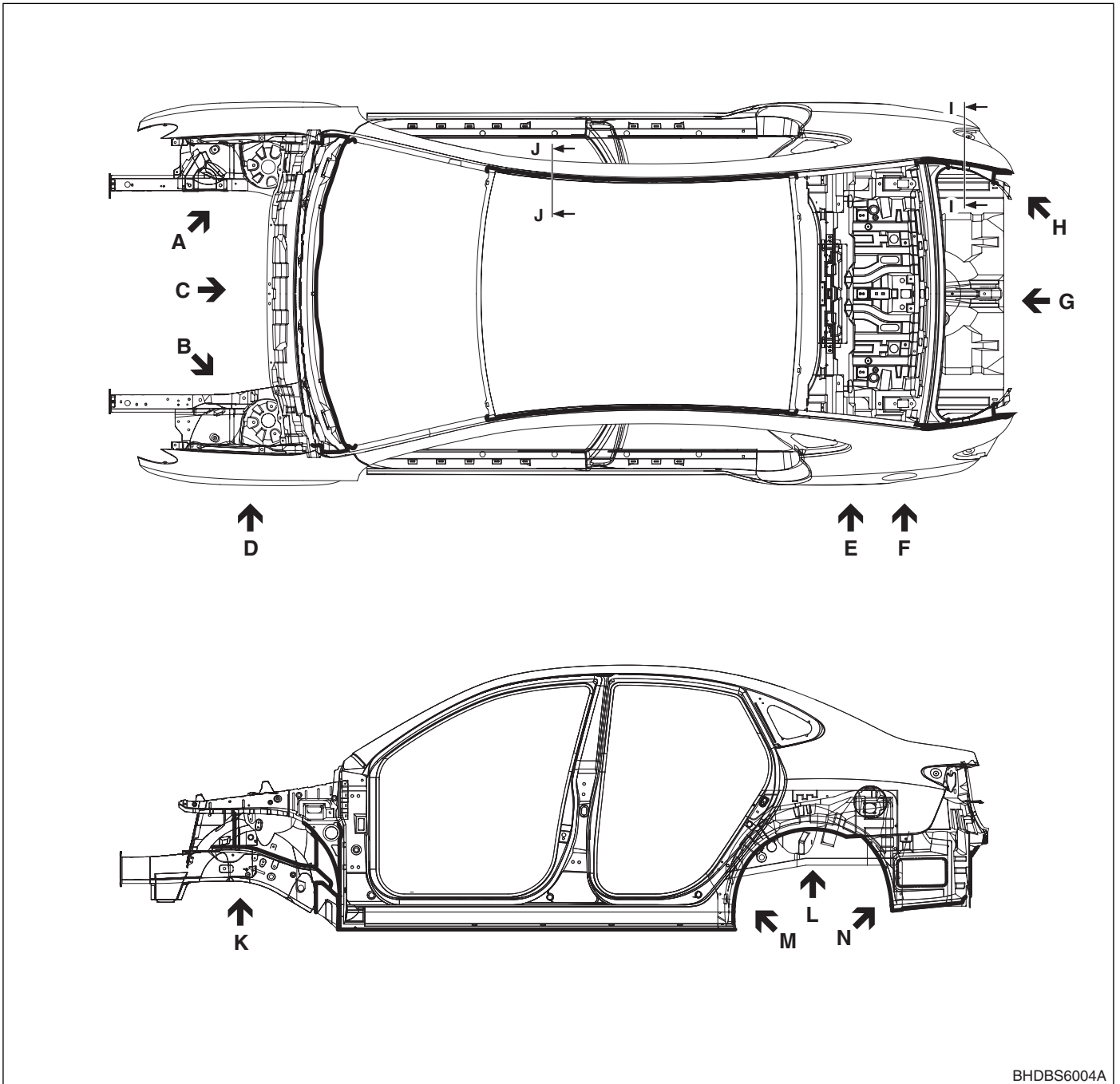

BHDBS6004A

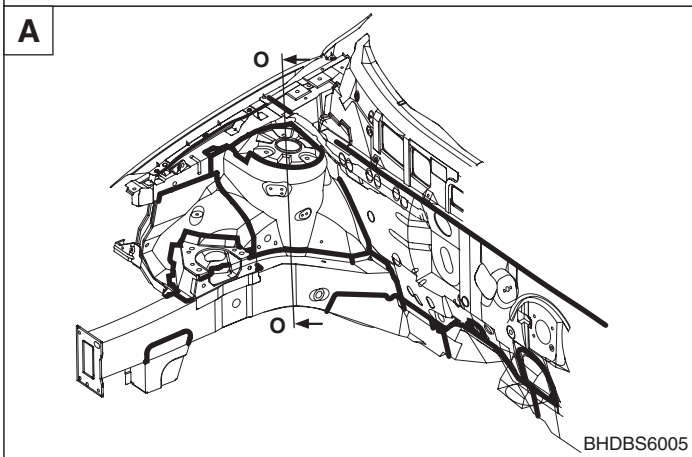

BHDBS6005

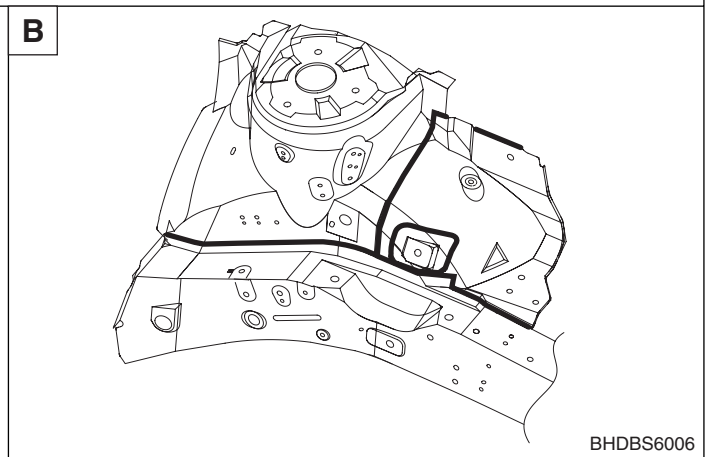

BHDBS6006

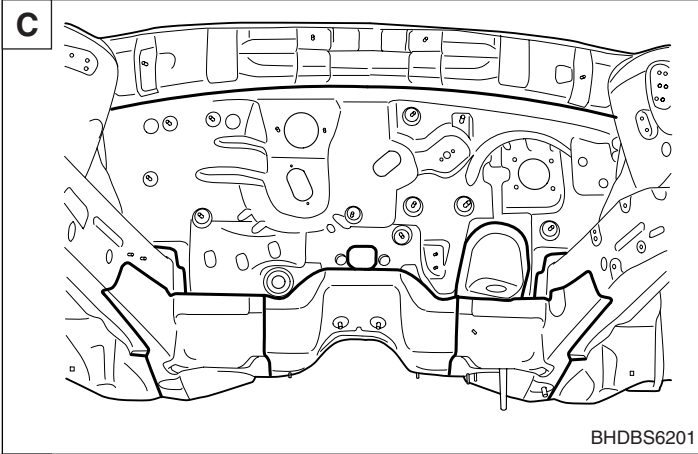

BHDBS6201

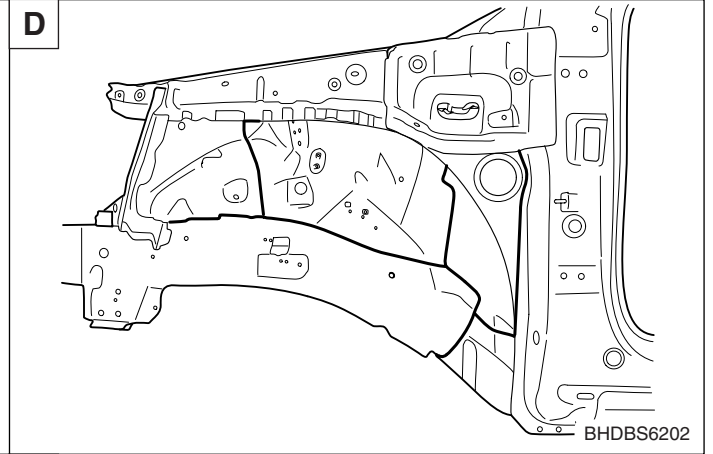

BHDBS6202

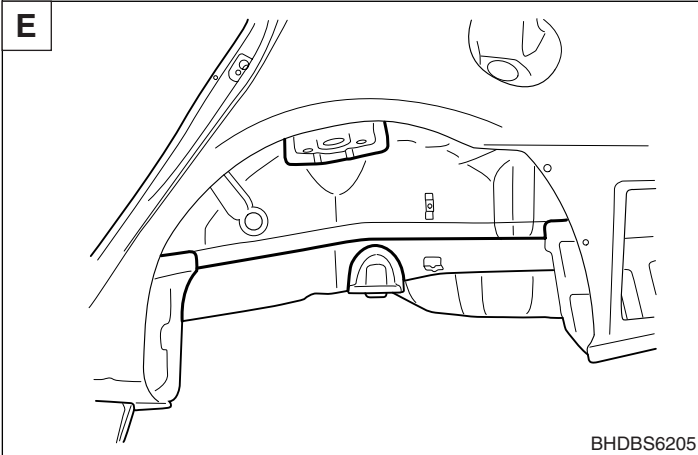

BHDBS6205

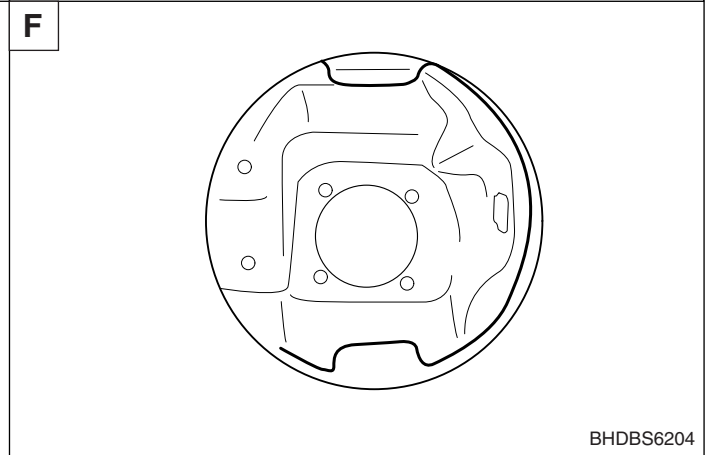

BHDBS6204

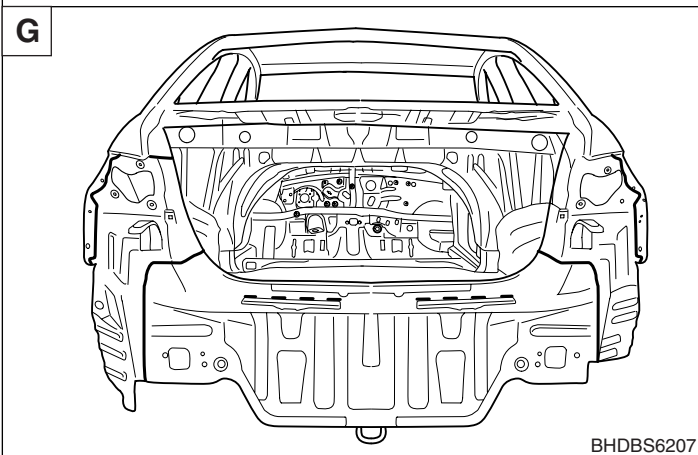

BHDBS6207

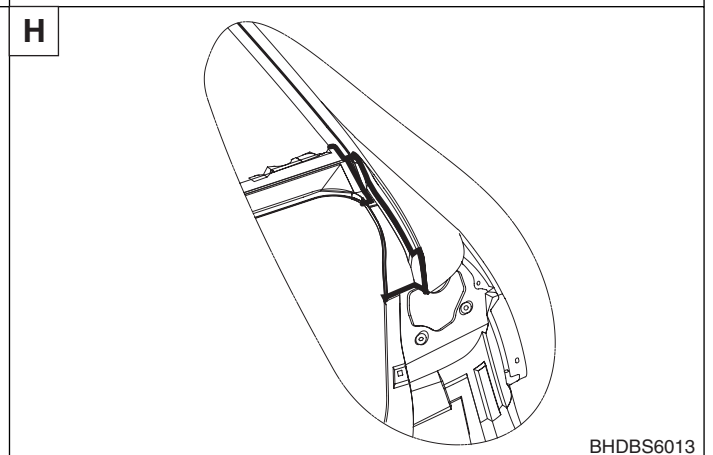

BHDBS6013

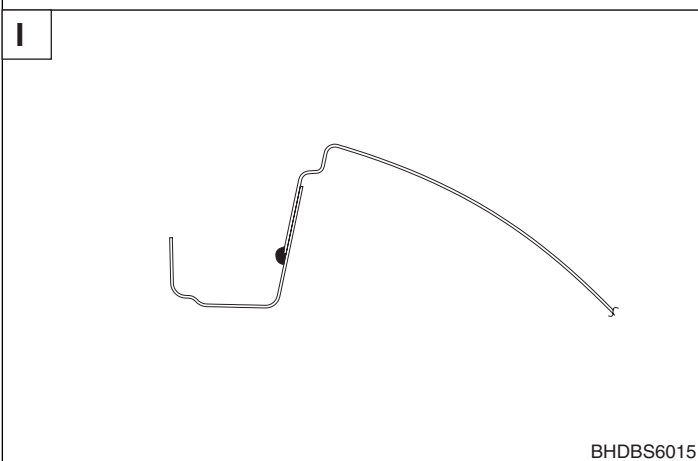

BHDBS6015

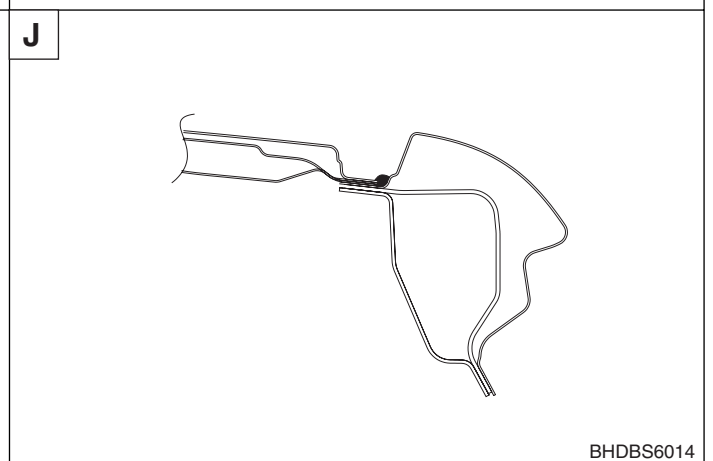

BHDBS6014

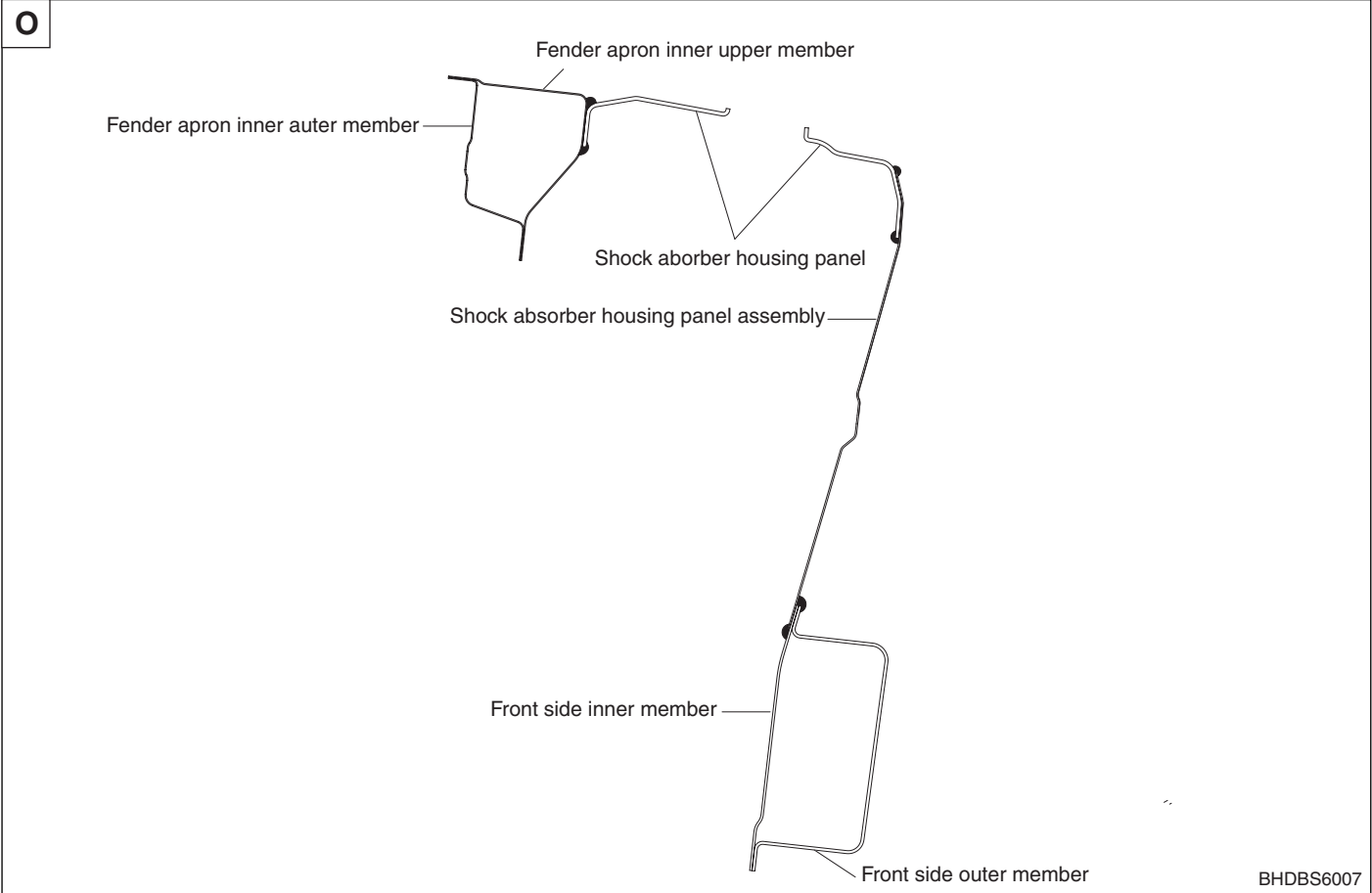
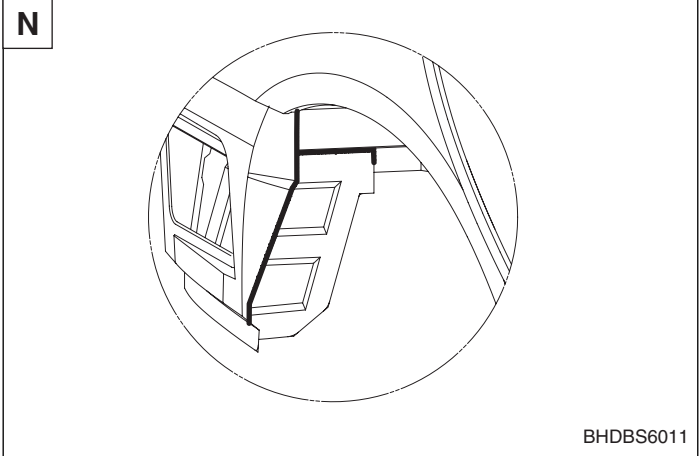
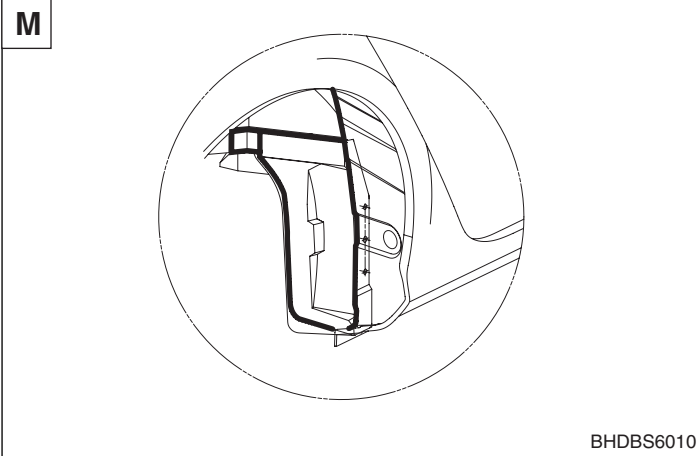
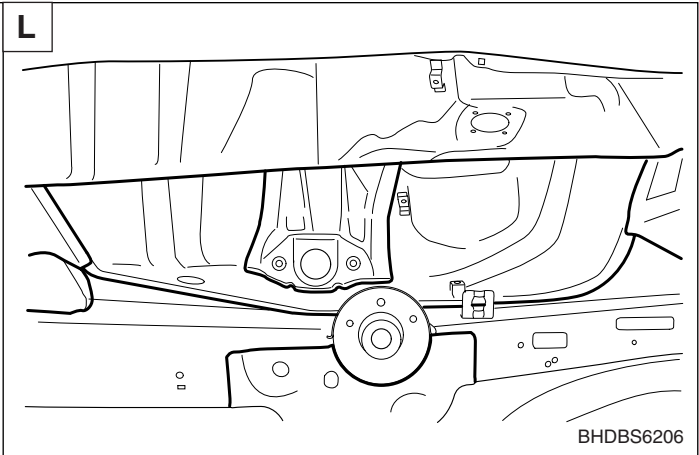
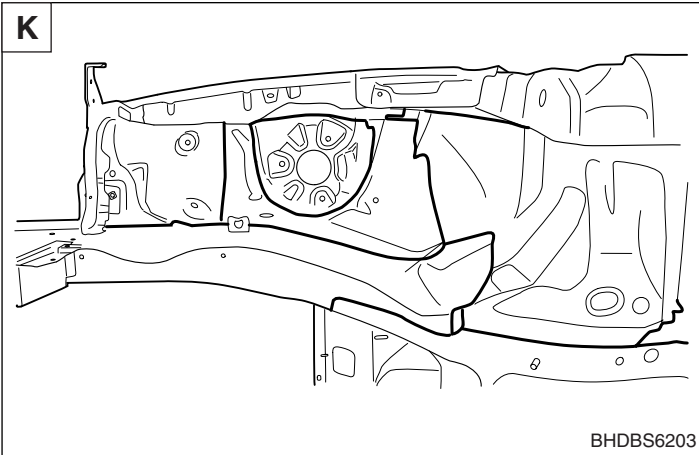

UNDER BODY

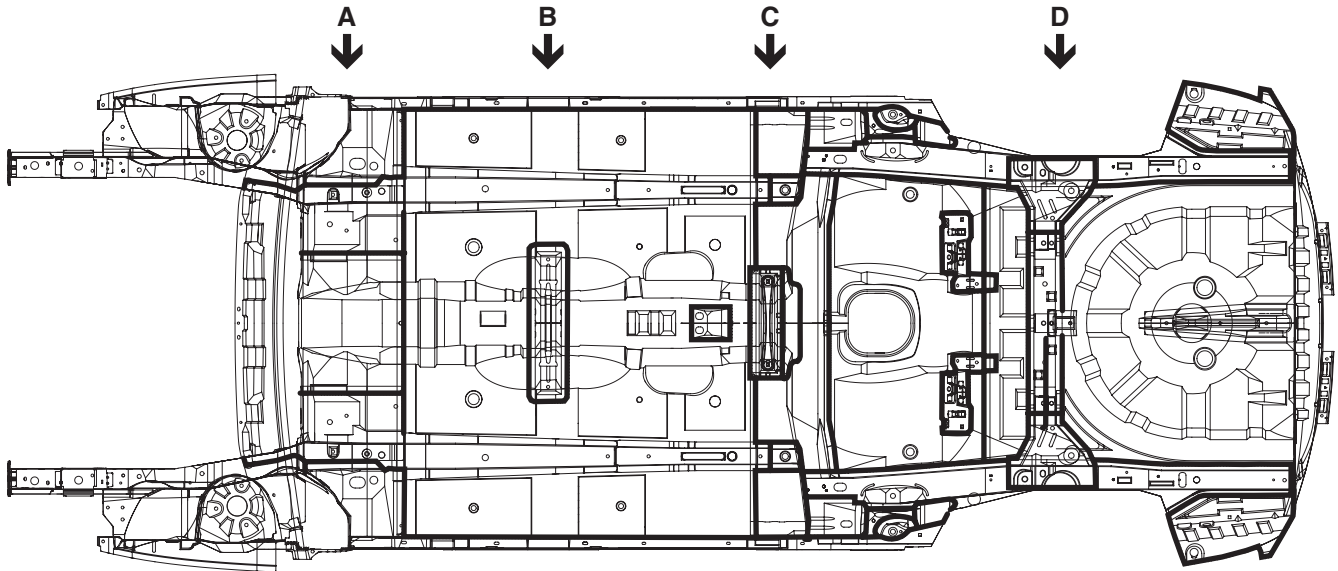

BHDBS6002

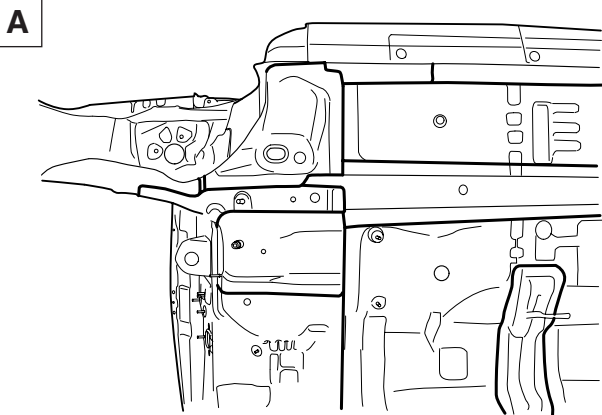

BHDBS6301

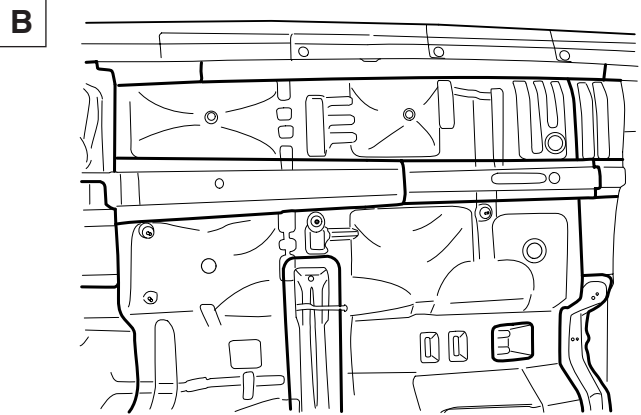

BHDBS6302

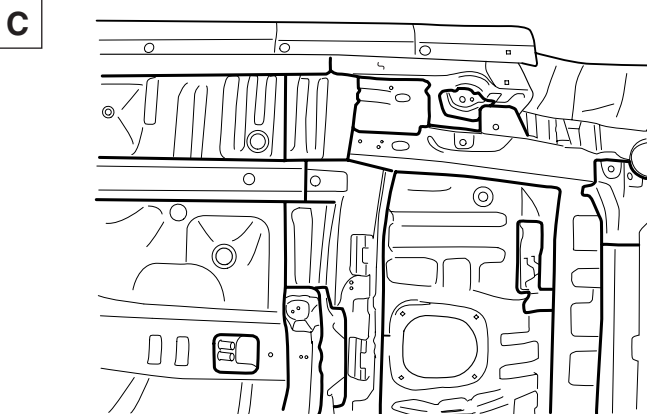

BHDBS6303

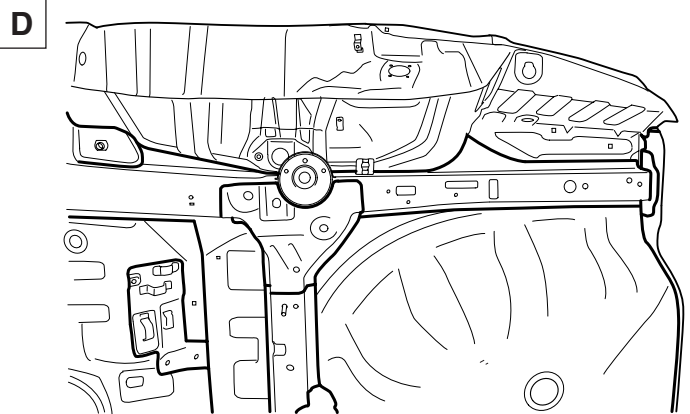

BHDBS6304

HOOD

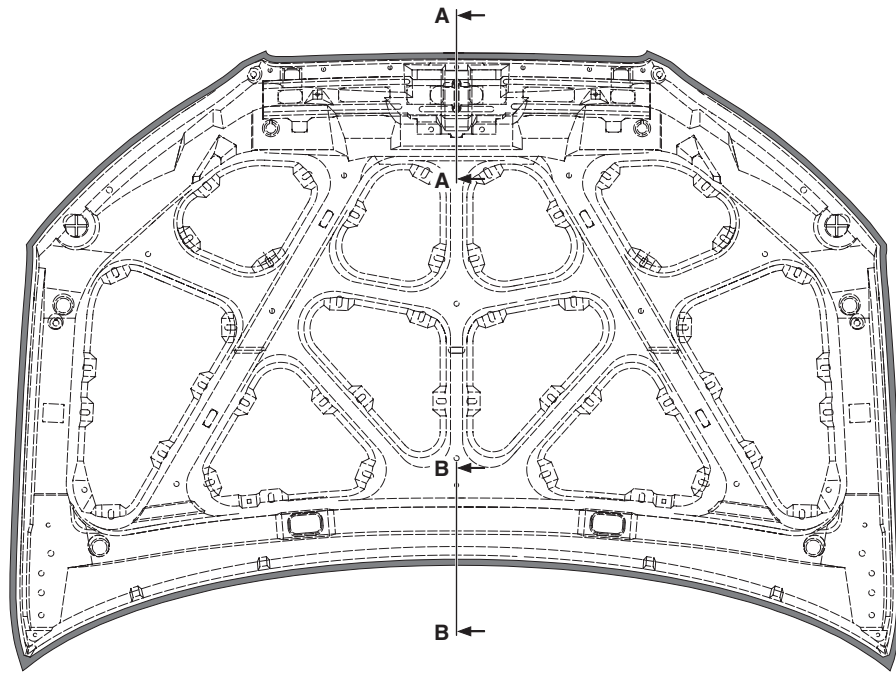

BHDWI6201

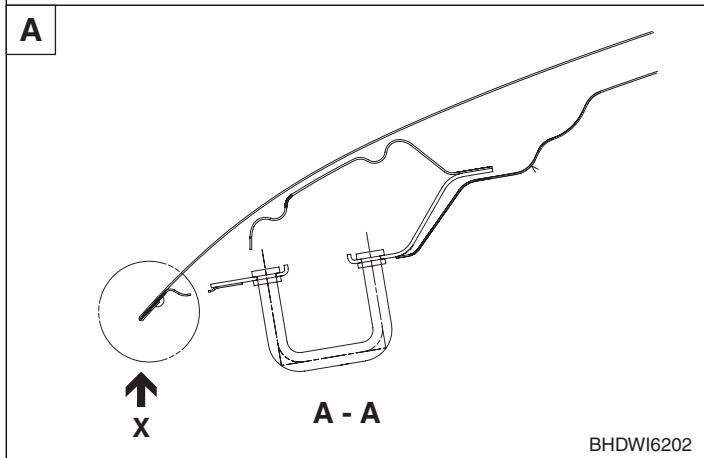

BHDWI6202

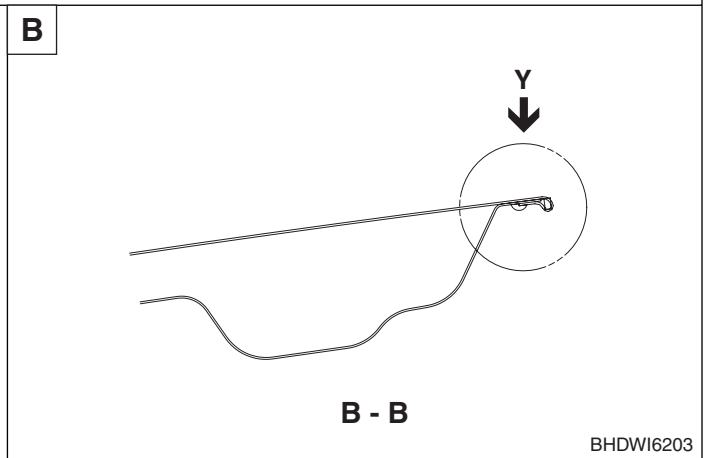

BHDWI6203

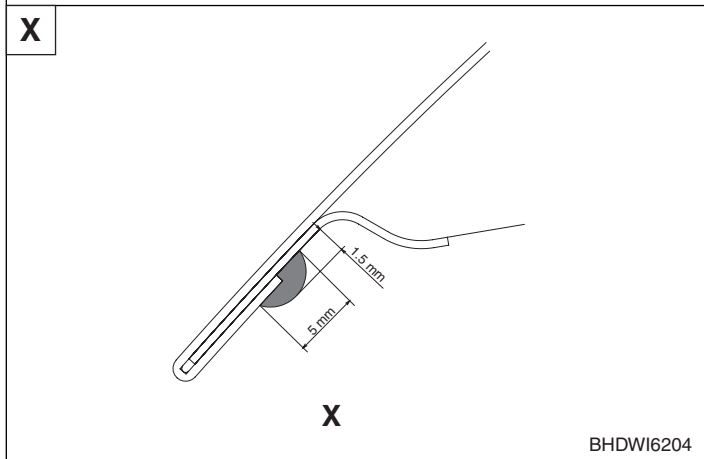

BHDWI6204

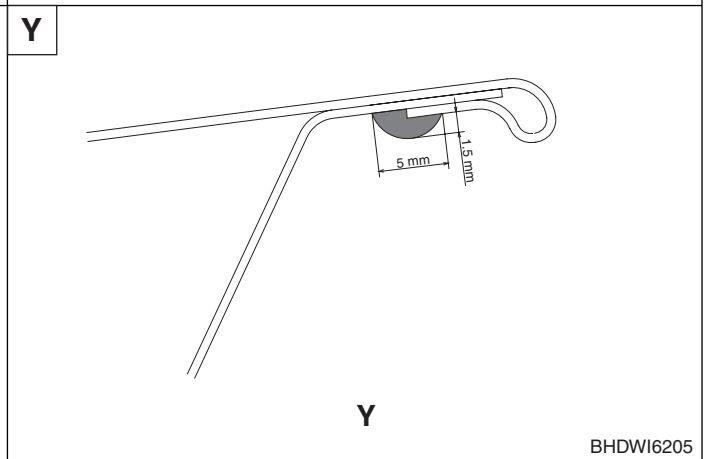

BHDWI6205

TRUNK LID

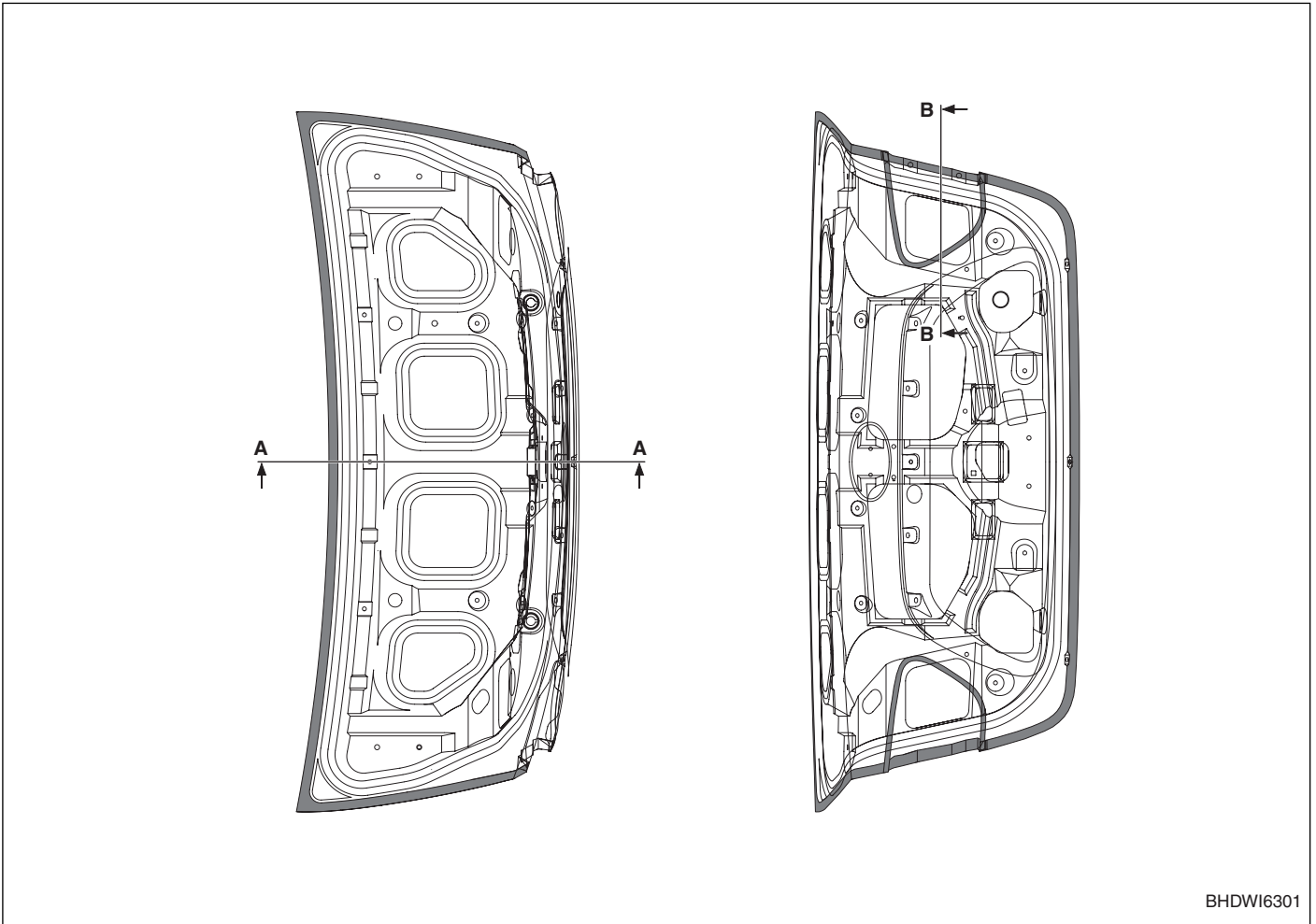

BHDWI6301

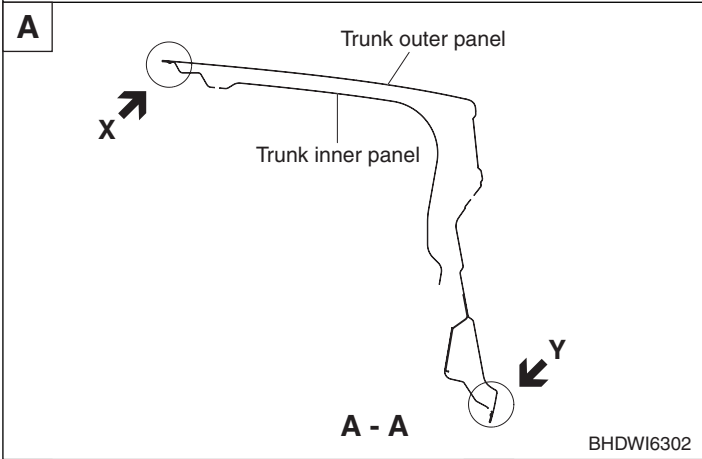

BHDWI6302

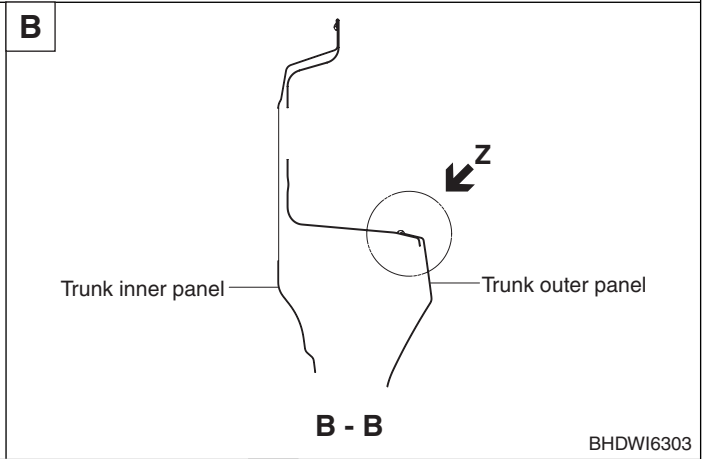

BHDWI6303

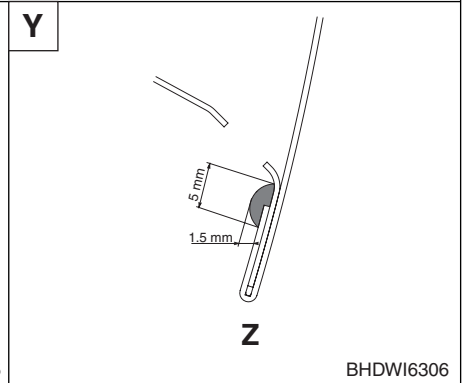
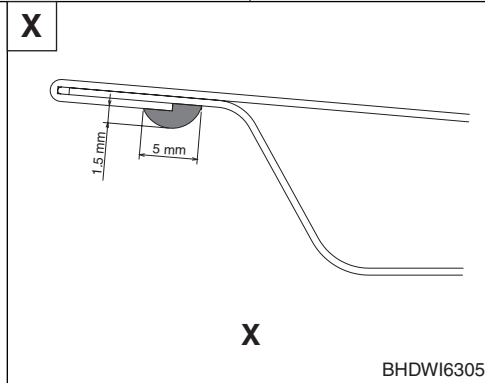
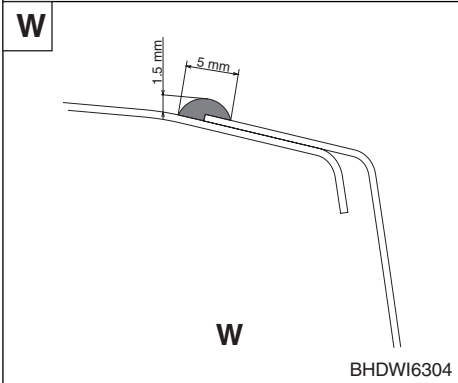

CORROSION PROTECTION

ZINC-PHOSPHATE COAT & CATIONIC ELECTRODEPOSITION PRIMER

In order to improve the adhesion of the paint coat on the steel panel, and also to improve the corrosion resistance, the entire body is coated with a film of Zinc-phosphate and a cationic electrodeposition primer.

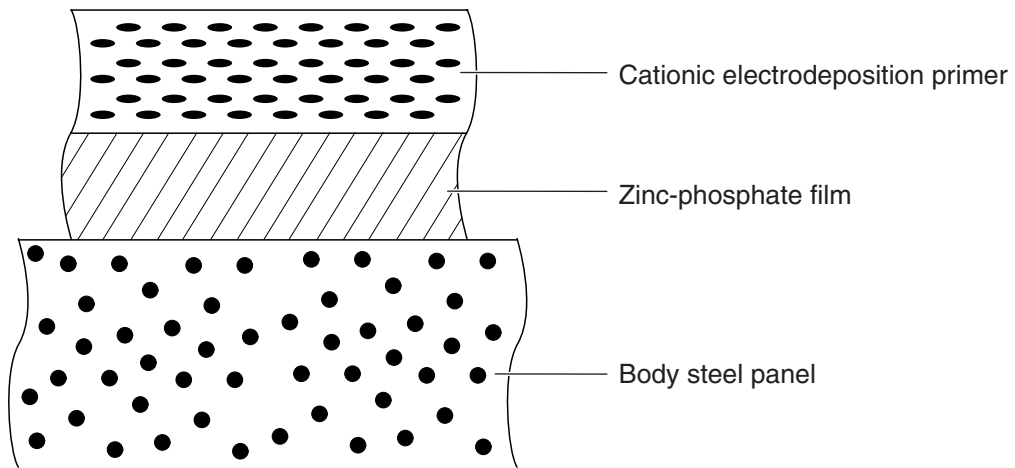

ANTIVIBRATION PADS-LOCATION & SECTION

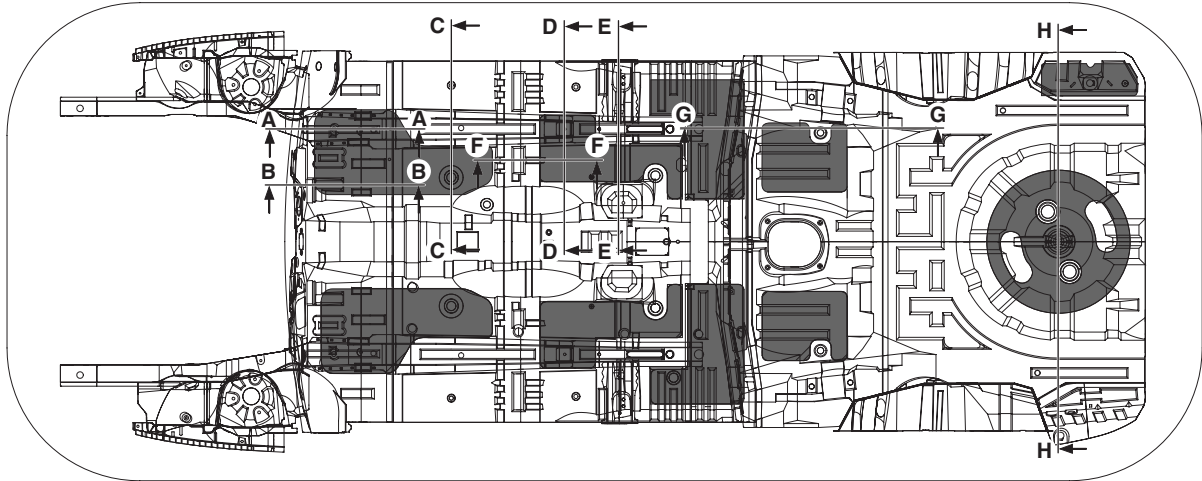

BHDCP6101

A

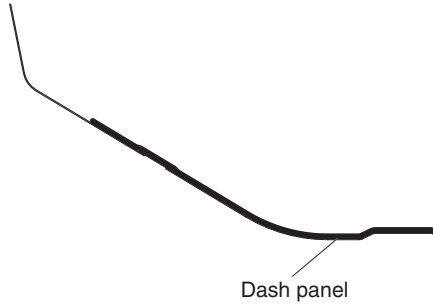

A - A

BCMCP6102

B

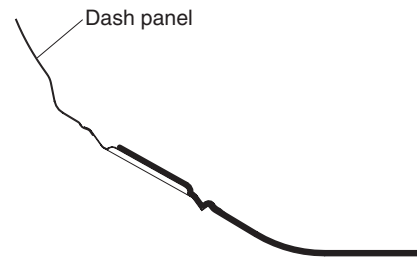

B - B

BCMCP6103

C

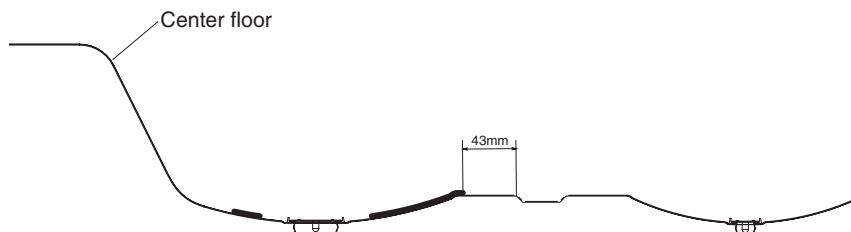

C - C

BHDCP6104

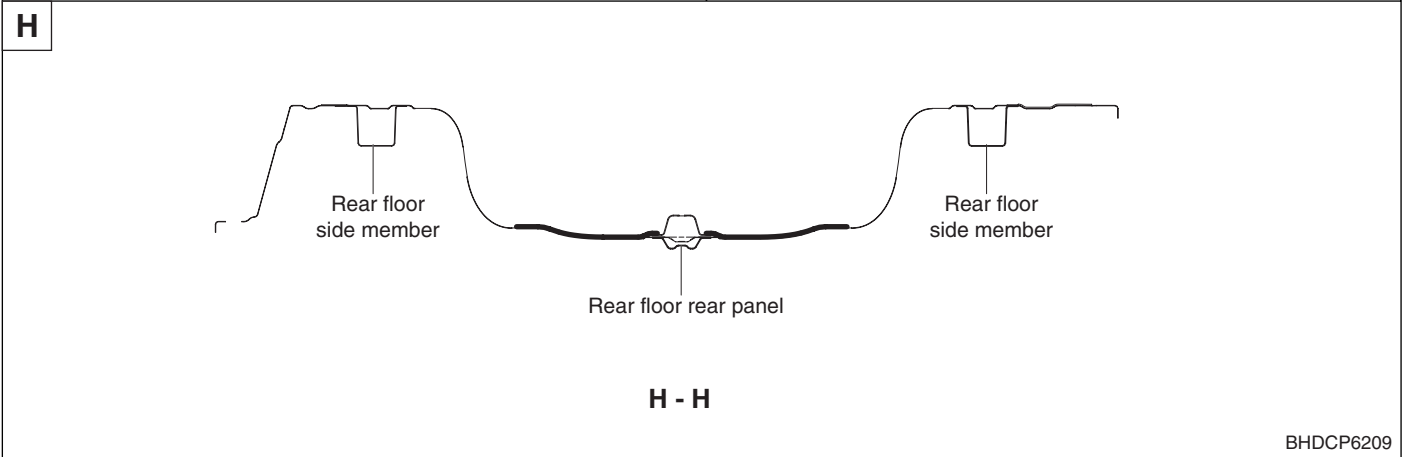
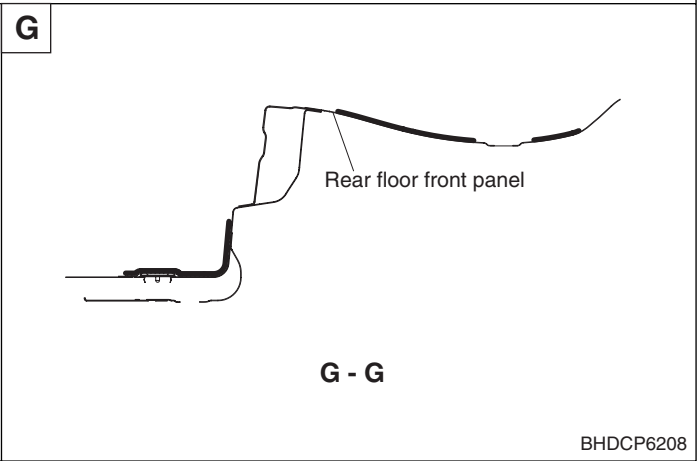
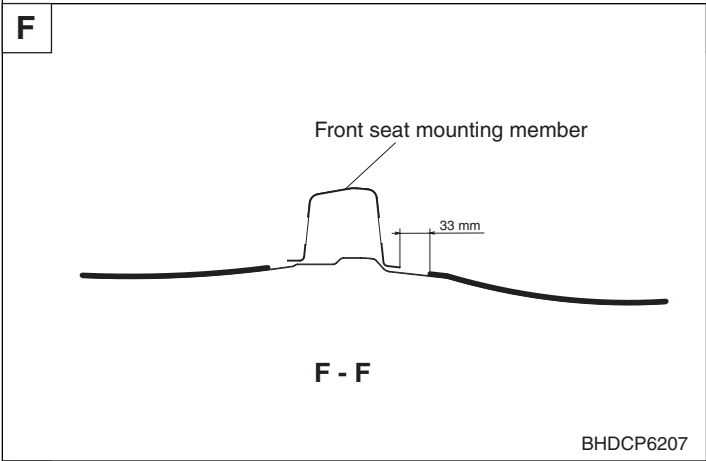
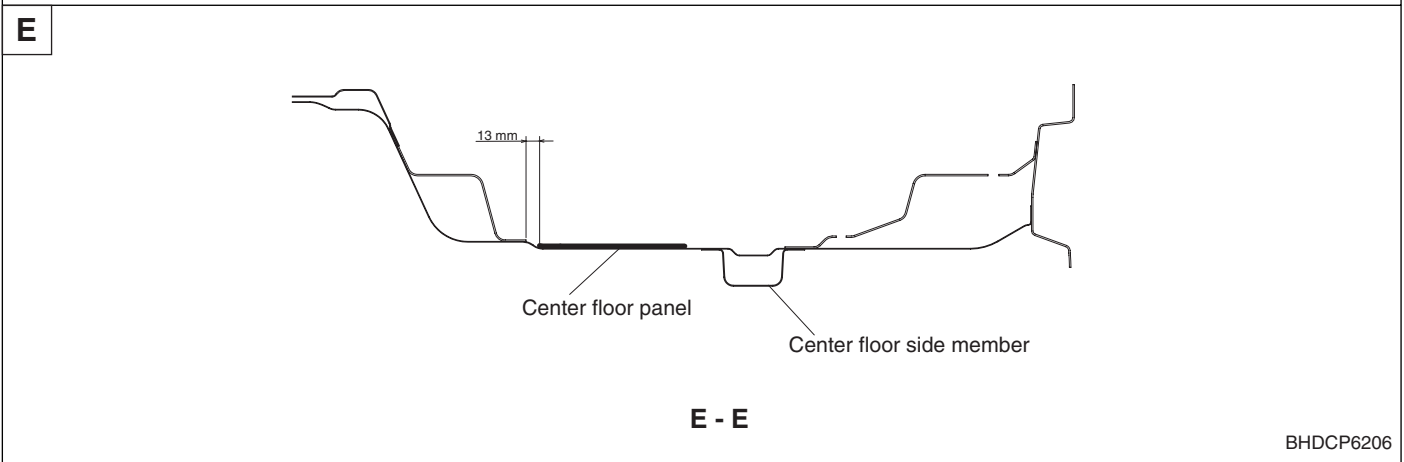
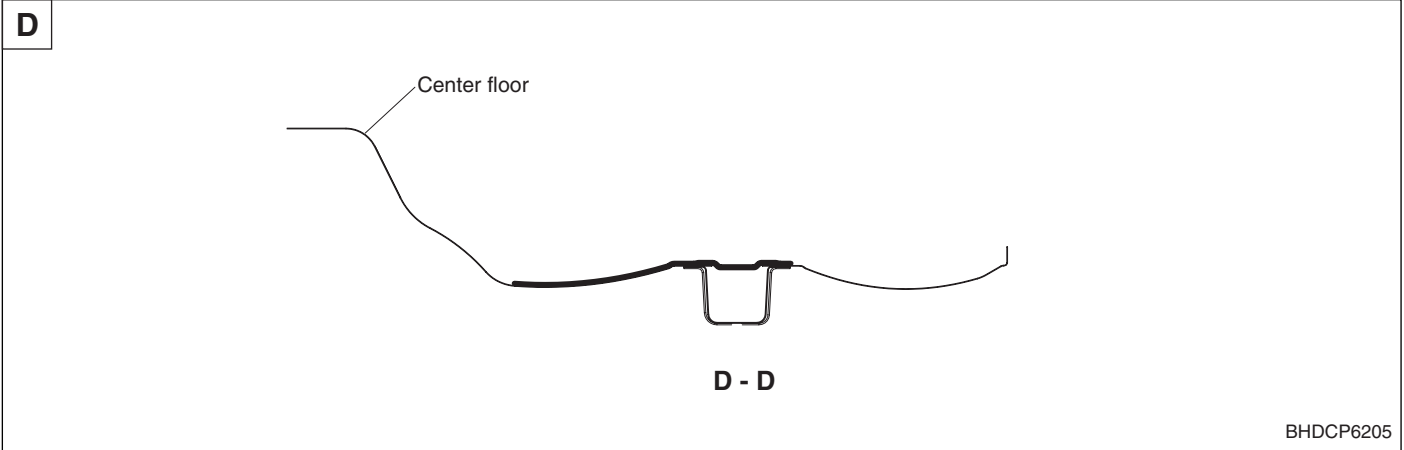

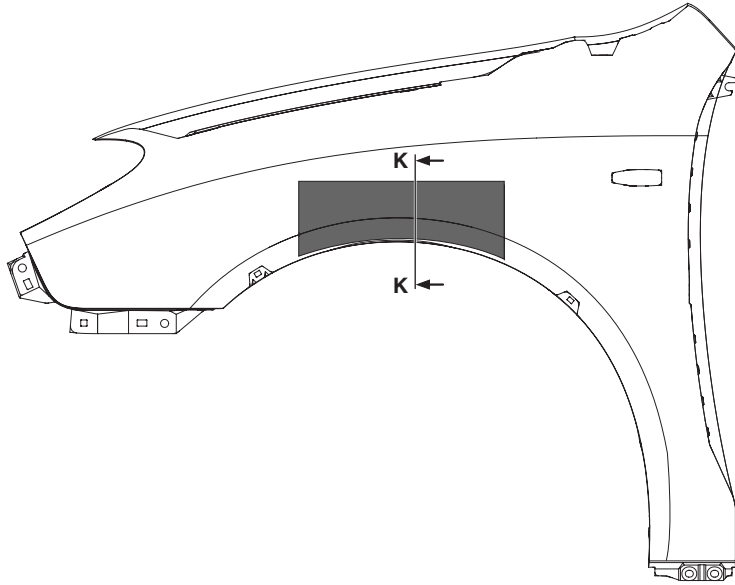

BHDCP6201

K



K - K

BHDCP6202

ATTACHMENT OF ANTIVIBRATION PADS

Antivibration pads are attached to the upper surface of the floor and at the interior side of the dash panel in order to absorb vibrations and shut out exhaust gas heat. If these antivibration pads are peeled off in the course of replacement or repair of a welded panel, cut and attach replacement material (in the shape shown in the figure).

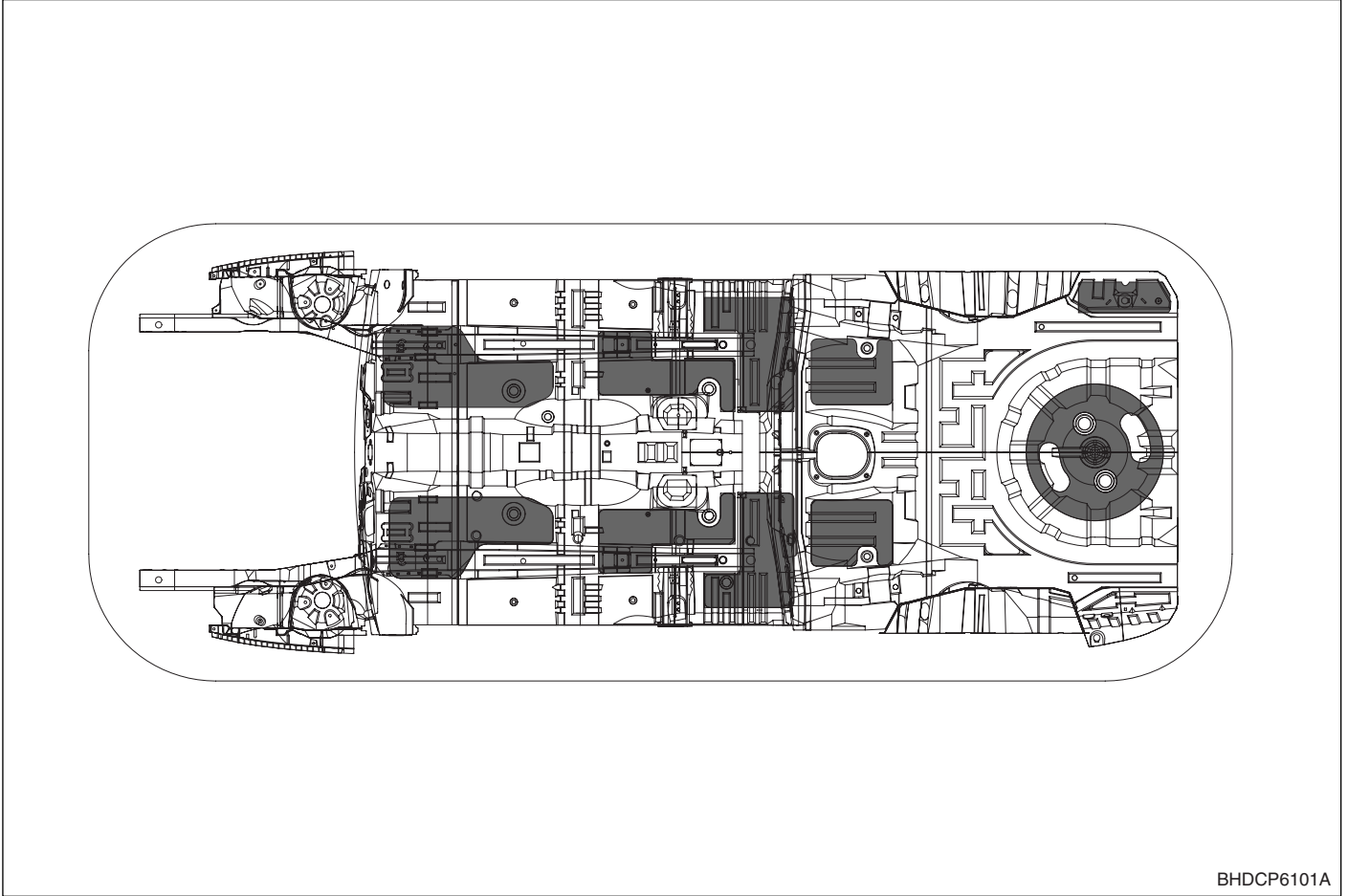

BHDCP6101A

1. Heat the "antivibration pad" with a blow drier to soften it.

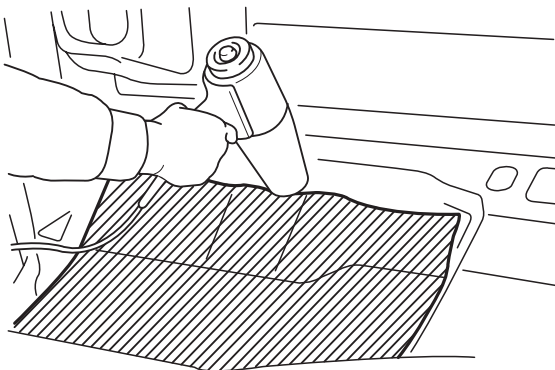

BMCCP6041

2. Align the antivibration pad layer in the position where it is to be installed, and then press it down with a roller or a block of wood so that it adheres well.

 **NOTE**

An infrared lamp can also be used to heat both the antivibration pad layer and the body panels (be sure to wear gloves).

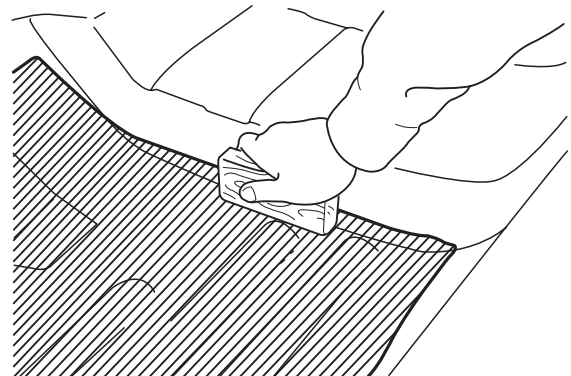

BMCCP6042

UNDER BODY COAT

In order to provide corrosion, stone chipping and vibration resistance, under body coat is applied to the under sides of the floor and wheel house.

Therefore, when such panel is replaced or repaired, apply under body coat to that part.

FLOOR

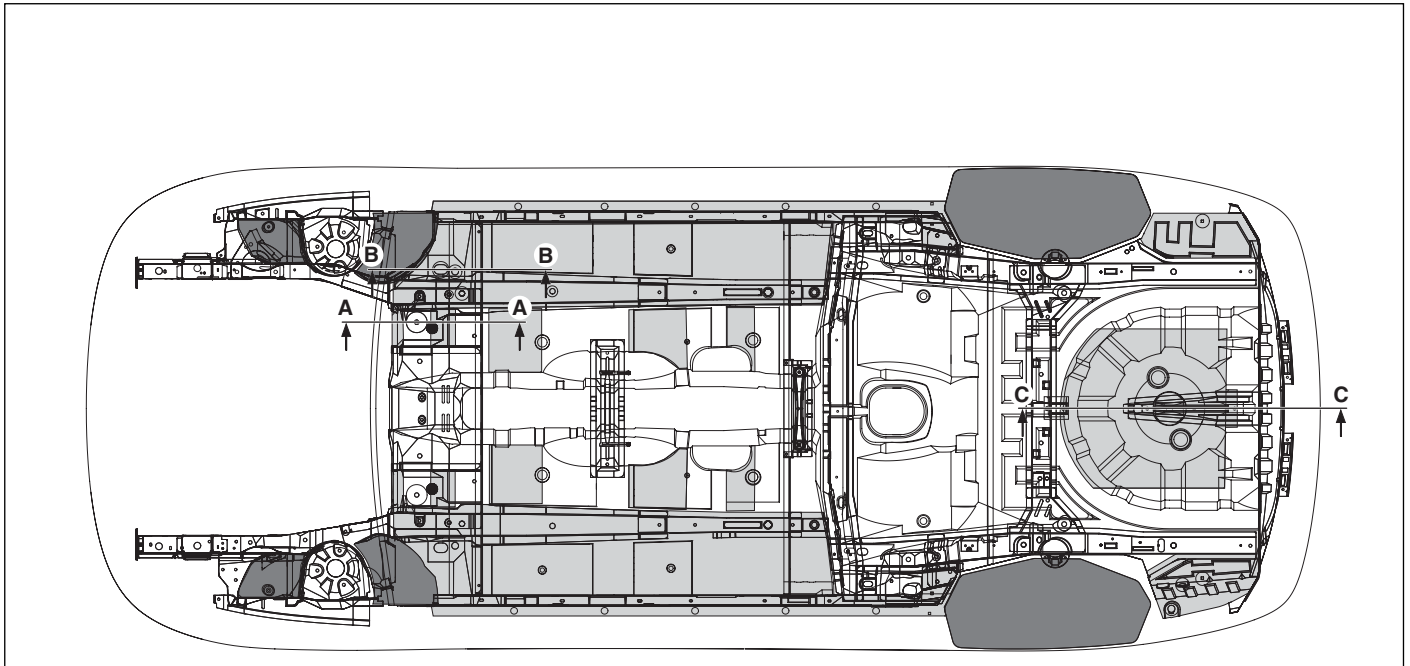

Under body coating (Thickness  : 0.8 mm ,  : 1.0 mm)

BHDCP6301

A

Front side rear lower member

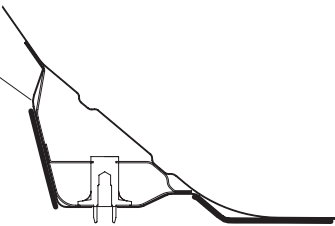

A - A

BHDCP6302

B

Side outer rear extension

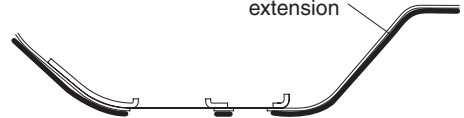

B - B

BHDCP6303

C

Rear floor center cross member

Rear floor rear panel

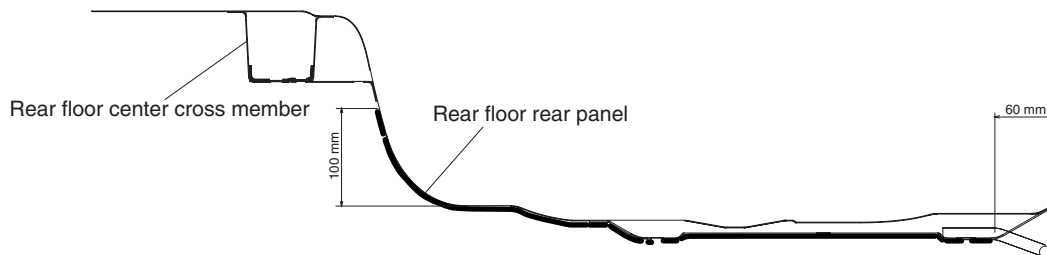

C - C

BHDCP6304

SIDE BODY

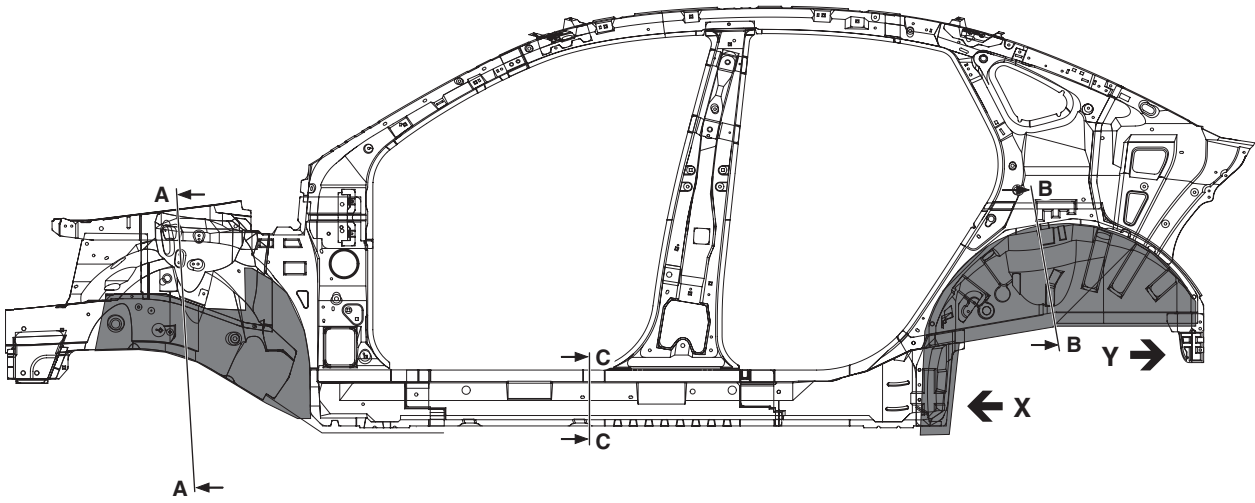

Under body coating (Thickness : 0.8 mm , : 1.0 mm)

BHDCP6401

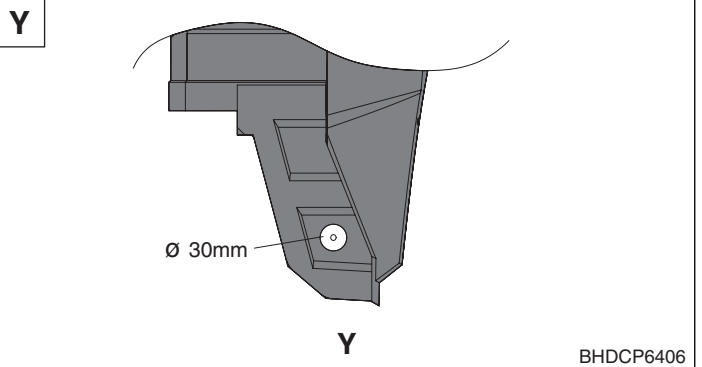
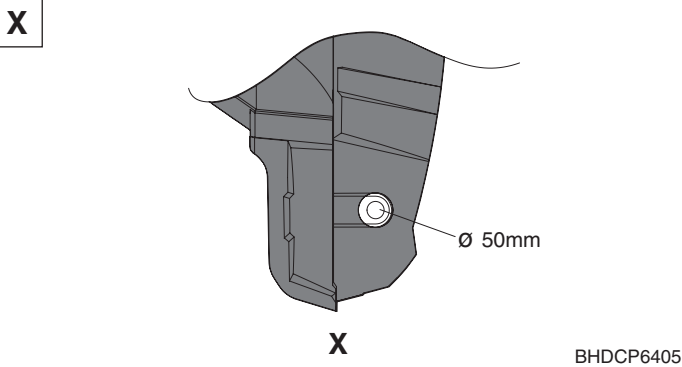
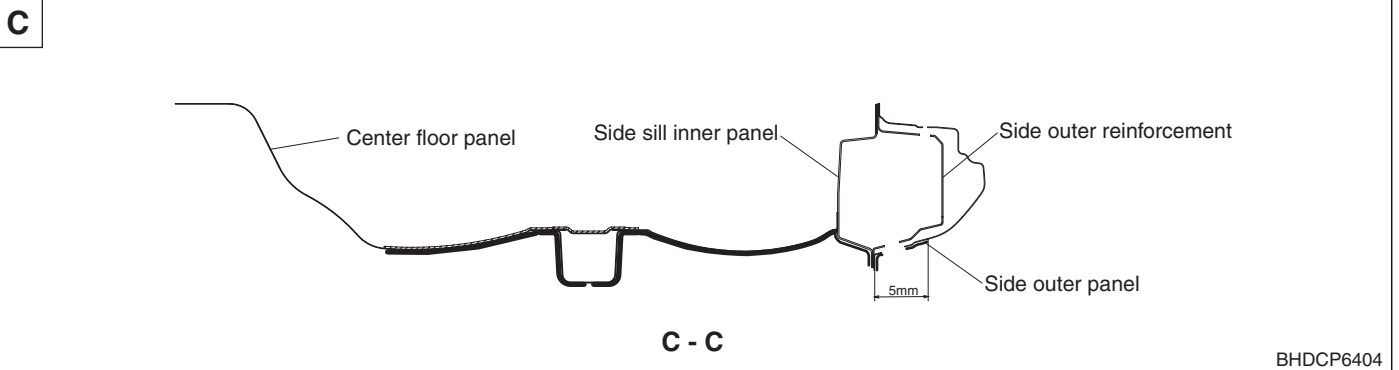
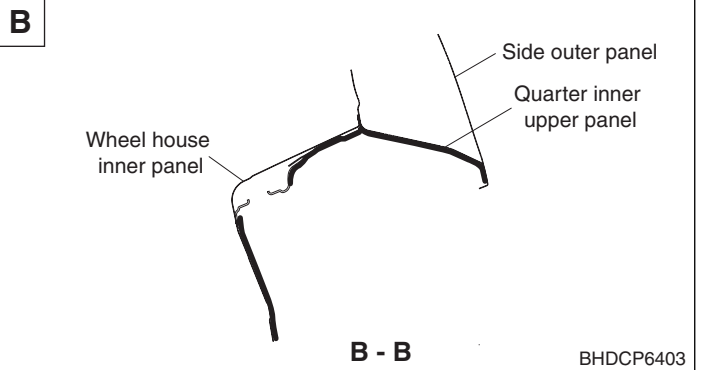
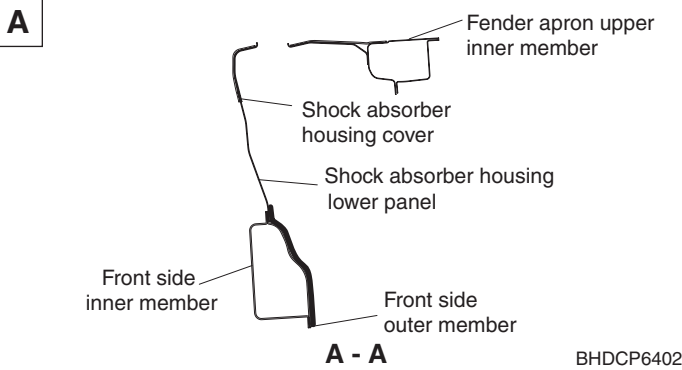

CAVITY WAX INJECTION

In order to provide greater corrosion resistance, cavity wax injection has been performed for the lower areas of the vehicle, such as the sidemember, the side sill and the inside of other panels which are a hollow construction. When replacing these parts, be such to apply cavity wax to the appropriate areas of the new parts.

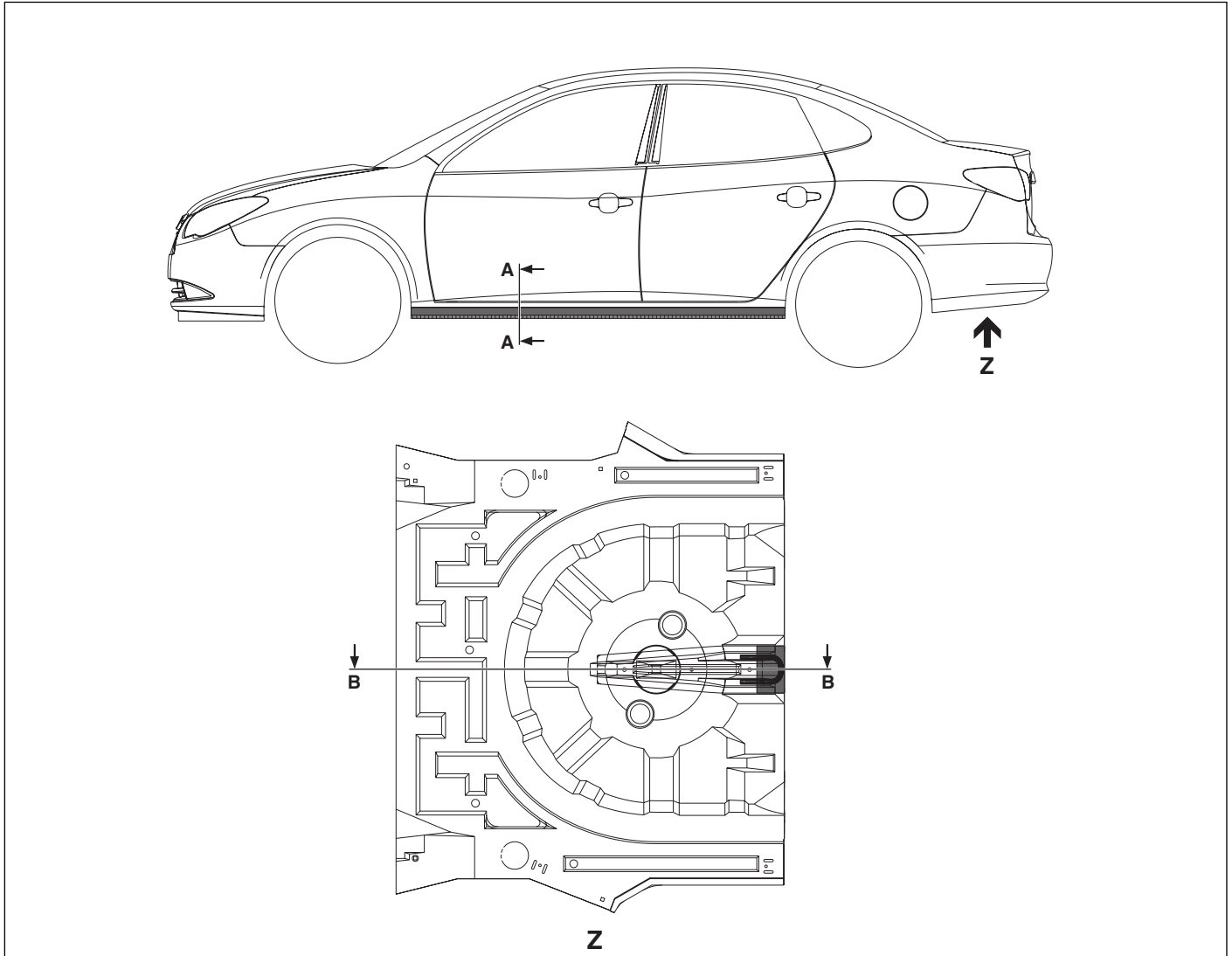

BHDWI6101

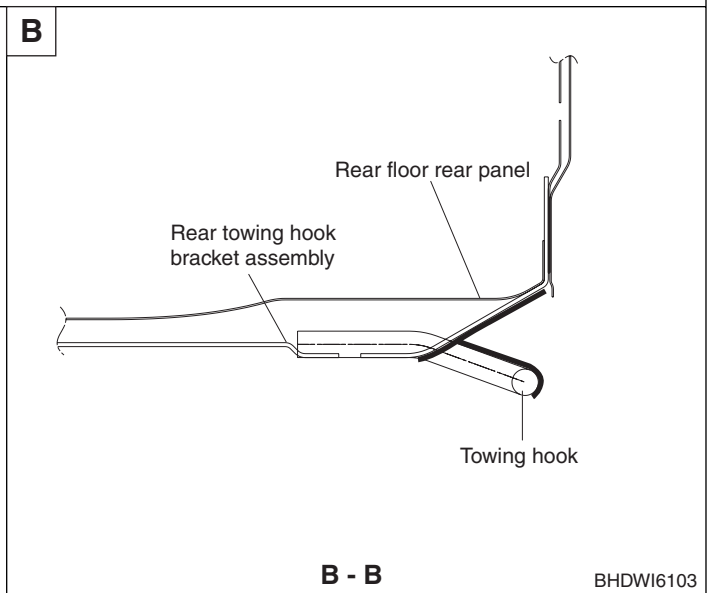
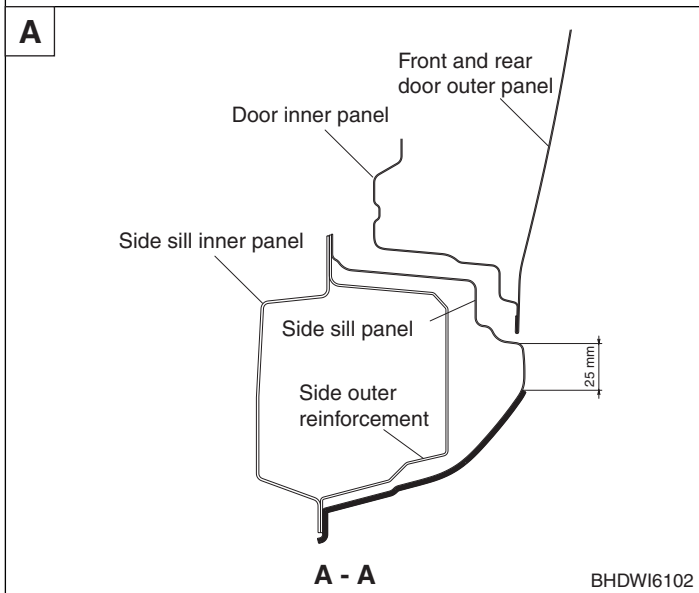

UNDER BODY ANTI-CORROSION AGENT

The undersides of the floor and wheel house are undercoated to provide greater corrosion resistance. Therefore, when such panel is replaced or repaired, apply under body anti-corrosion agent to that part.

**NOTE**

Do not apply the under body anti-corrosion agent to come in contact with tires, muffler and exhaust pipe.

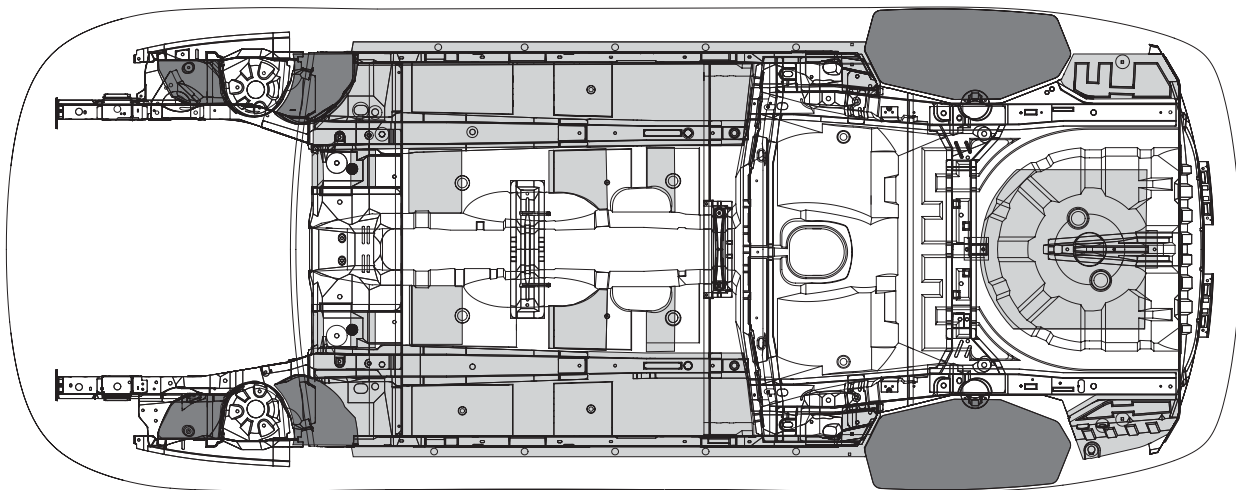

Under body coating (Thickness  : 0.8 mm ,  : 1.0 mm)

BODY MODIFICATION TOOLS

BODY MODIFICATION TOOLS

MODIFICATION TOOLS

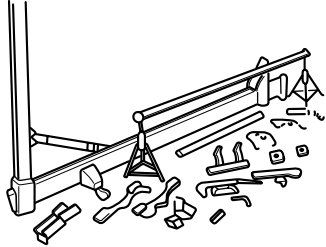
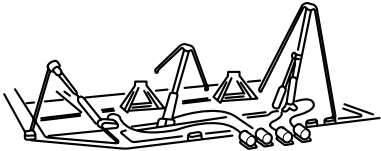
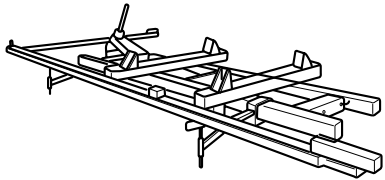
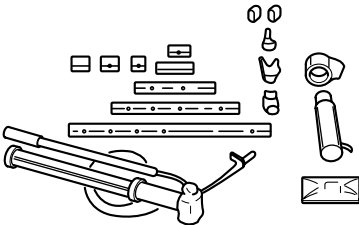
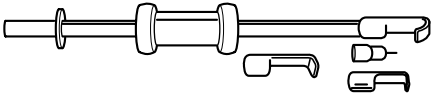
Name	Used for	Figure
<p>Frame straightener</p>	<p>Modify twisted or bent body</p>	 <p>A3EB3501</p>
		 <p>A3EB3502</p>
		 <p>A3EB3503</p>
<p>Port power</p>	<p>Push out, stretch, pull in damaged area</p>	 <p>A3EB3504</p>
<p>Body puller</p>	<p>Stretch damaged area</p>	 <p>A3EB3505</p>

CUT AND DISASSEMBLY TOOLS

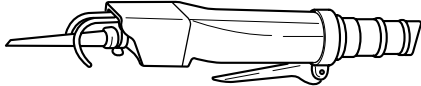
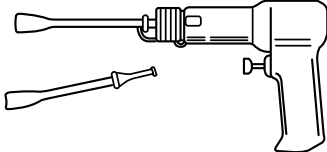
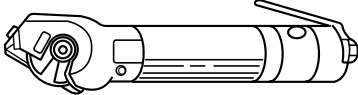
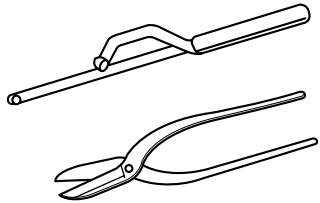
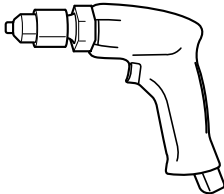
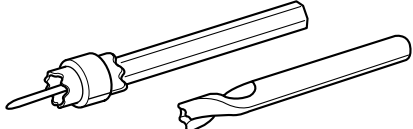
Name	Used for	Figure
<p>Air saw</p>	<p>Cut a panel</p>	 <p>A3EB3506</p>
<p>Air chisel</p>	<p>Cut or bend a panel, cut and disassemble spot welded area</p>	 <p>A3EB3507</p>
<p>Rotary cutter</p>	<p>Cut a panel</p>	 <p>A3EB3508</p>
<p>Hand saw and metal scissors</p>	<p>Cut a panel</p>	 <p>A3EB3509</p>
<p>Air drill</p>	<p>Fix a spot cutter or drill to cut or disassembly spot welding area, to finish a hole</p>	 <p>A3EB3510</p>
<p>Spot cutter</p>	<p>Cut and disassemble spot welded area</p>	 <p>A3EB3511</p>

ASSEMBLY TOOLS

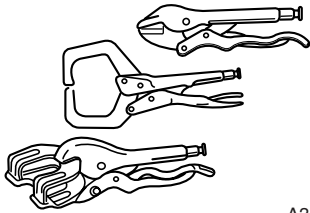
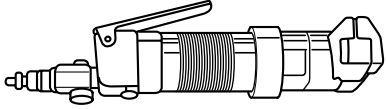
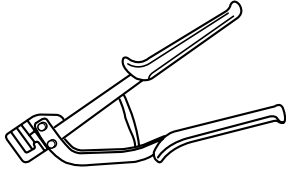
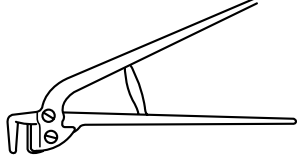
Name	Used for	Figure
Vice pliers	Fix a panel or area to weld	 <p>A3EB3512</p>
Air bench	Finish contact area of flange and finish a hole for plug welding	 <p>A3EB3513</p>
Quick bench	Finish a hole for plug welding	 <p>A3EB3514</p>
Flanging tool	Finish contact area of flange	 <p>A3EB3515</p>

MEASUREMENT TOOLS

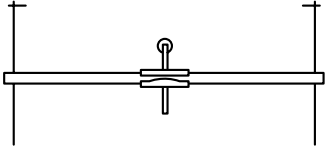
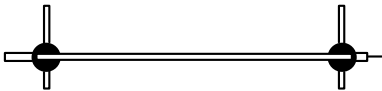
Name	Used for	Figure
Centering gauge	Measure distortion of body and frame	 <p>A3EB3516</p>
Tracking gauge	Measure body and frame	 <p>A3EB3517</p>

WELDING MACHINE

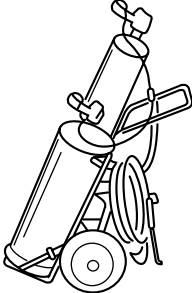
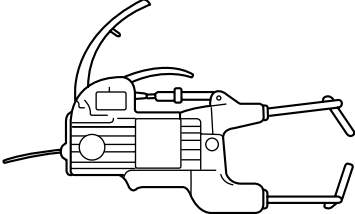
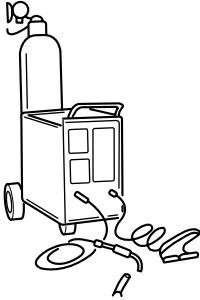
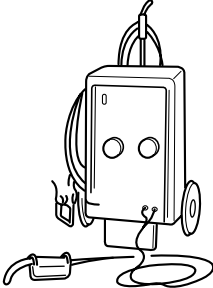
Name	Used for	Figure
<p>Gas welding machine</p>	<p>Cut a panel</p>	 <p>A3EB3518</p>
<p>Spot welding machine</p>	<p>Weld a panel</p>	 <p>A3EB3519</p>
<p>Carbon arc welding machine</p>	<p>Weld a panel</p>	 <p>A3EB3520</p>
<p>Stud welding machine</p>	<p>Stretch a panel, weld a stud bolt to fix front window mold clip</p>	 <p>A3EB3521</p>

BUFFING AND GRINDING TOOLS

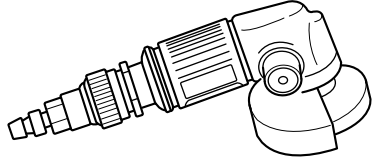
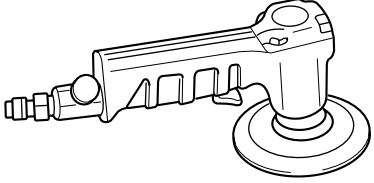
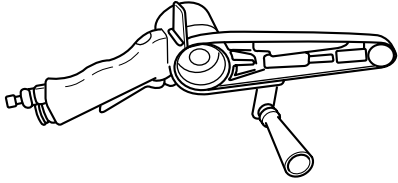
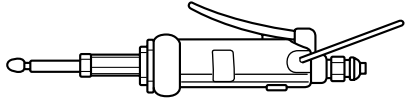
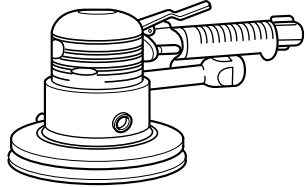
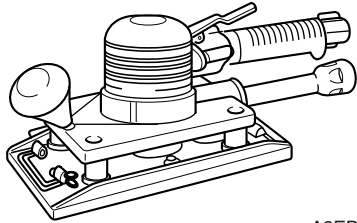
Name	Used for	Figure
Disk grinder	Buff	 <p>A3EB3522</p>
Disk sander	Buff	 <p>A3EB3523</p>
Belt sander	Buff paints	 <p>A3EB3524</p>
Small sized grinder	Buff paints or smooth finishing	 <p>A3EB3525</p>
Double action sander	Grind rough area of puttee assembled area	 <p>A3EB3526</p>
Orbital sander(short)	Grind rough area of puttee assembled area	 <p>A3EB3527</p>

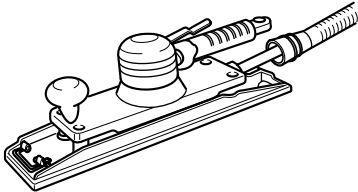
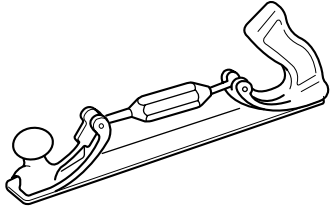
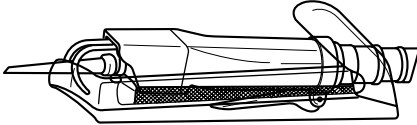
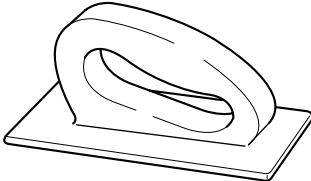
Name	Used for	Figure
<p>Orbital sander(long)</p>	<p>Used for puttee grinding of wide area</p>	 <p>A3EB3528</p>
<p>Flexible file</p>	<p>Grind touch up area, uneven area of a panel</p>	 <p>A3EB3529</p>
<p>Surform tool</p>	<p>Buff rough area of puttee area</p>	 <p>A3EB3530</p>
<p>Hand file</p>	<p>Grind body puttee, pulley, finish puttee</p>	 <p>A3EB3531</p>

HANDHELD TOOLS

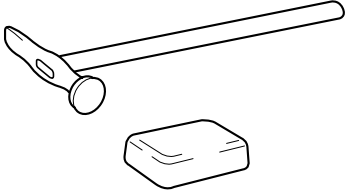
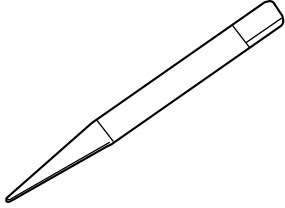
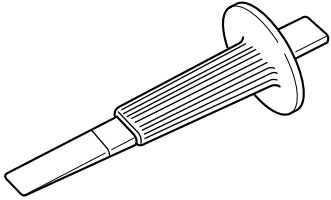
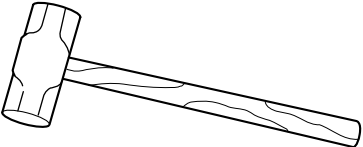
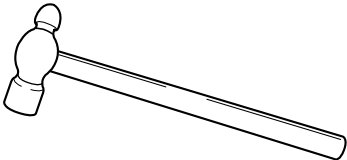
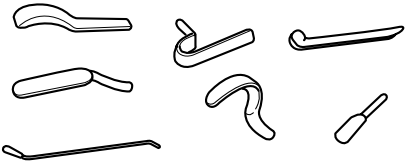
Name	Used for	Figure
<p>Body hammer and dolly</p>	<p>-</p>	 <p>A3EB3532</p>
<p>Center punch</p>	<p>Punch a hole in the middle of a spot welding area</p>	 <p>A3EB3533</p>
<p>Plane chisel</p>	<p>Cut and disassemble a panel</p>	 <p>A3EB3534</p>
<p>Weight hammer</p>	<p>Used when greater force is required</p>	 <p>A3EB3535</p>
<p>Bowl pin hammer</p>	<p>Used when smaller force is required</p>	 <p>A3EB3536</p>
<p>Spoon</p>	<p>Used for an area where not reached by hand</p>	 <p>A3EB3537</p>

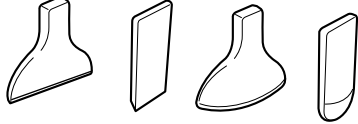
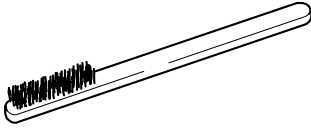
Name	Used for	Figure
<p>Body chisel</p>	<p>Bend rough body line damaged or sheet metal etc.</p>	 <p>A3EB3538</p>
<p>Wire brush</p>	<p>Remove paints, rust, slag on welded area which are hard to recognize</p>	 <p>A3EB3539</p>

REPAIR TOOLS SET

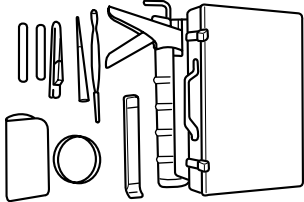
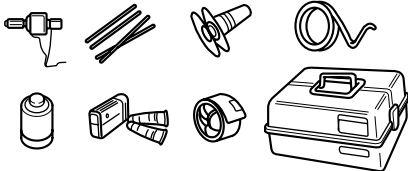
Name	Used for	Figure
<p>Window tool set</p>	<p>Repair window collar</p>	 <p>A3EB3540</p>
<p>Repair tool set for plastics</p>	<p>Repair plastic parts</p>	 <p>A3EB3541</p>

PLASTIC PARTS

POLYPROPYLENE(PP) BUMPER

REPAIRABILITY

The three types of damaged bumpers shown below can be repaired. Because of cost and quality considerations, bumpers with more damage may be repaired, but replacing the bumper is encouraged.

1. If a hole on a bumper is less than 2 in.(50 mm).

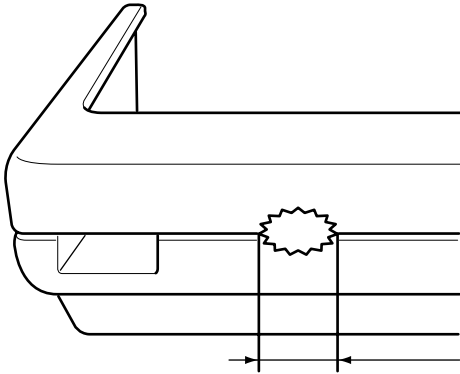

A3EB3601

2. If a crack on a bumper is less than 4 in.(100 mm).

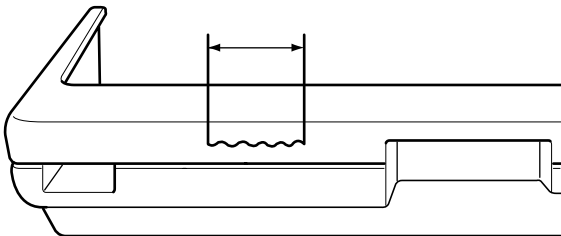

A3EB3602

3. If a crack on bumper section is [A] is less than 4 in. (100 mm) (less than half of the bumper height).

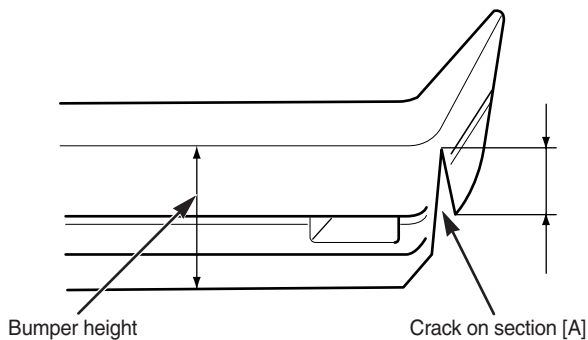

A3EB3603

BUMPER REPAIR PROCEDURE

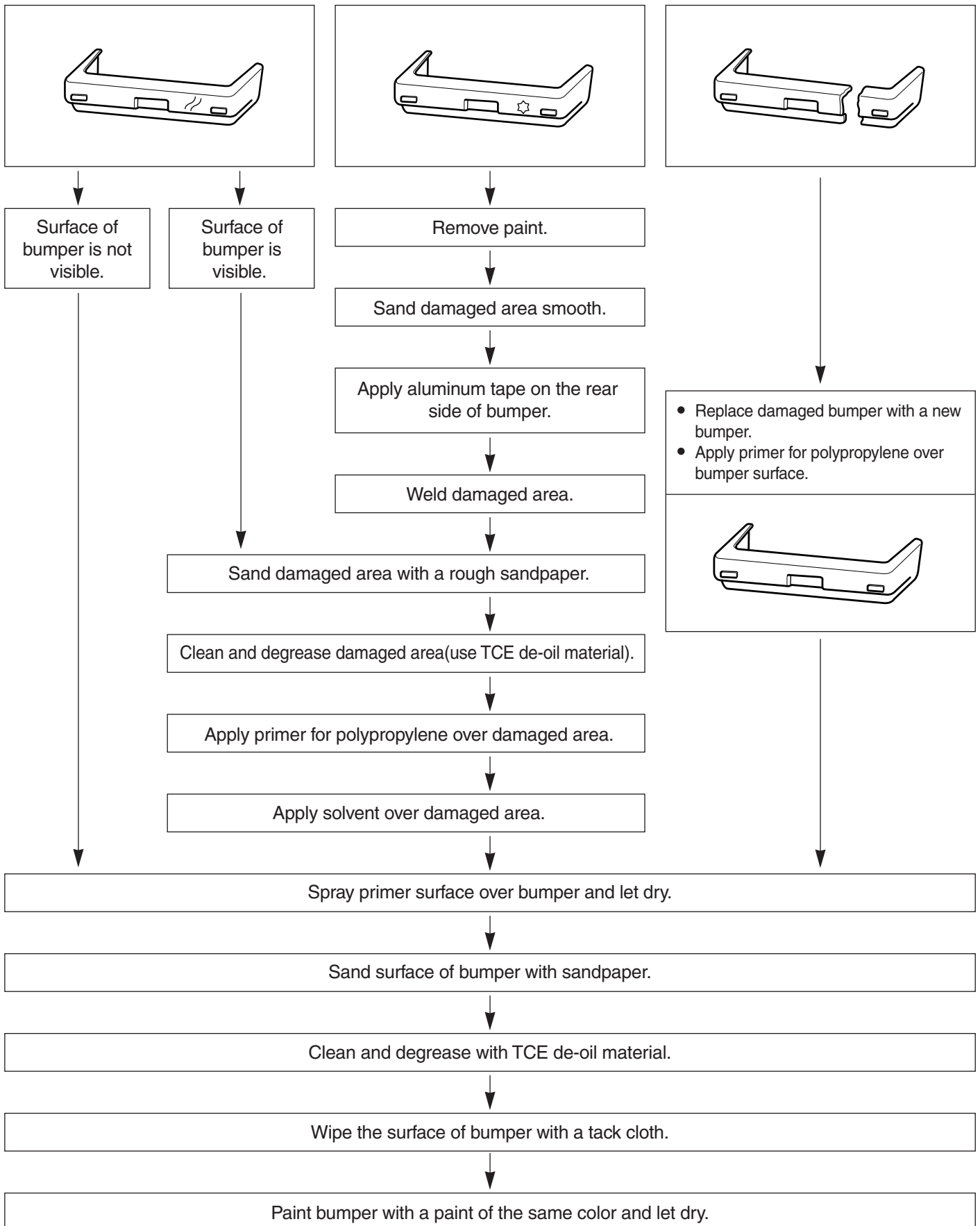

REPAIR METHOD FOR PP BUMPER

Damage to the bumper that reaches the surface of the polypropylene cannot be fixed just by painting. Use the repair methods shown below to repair damage that reaches the surface of the polypropylene.

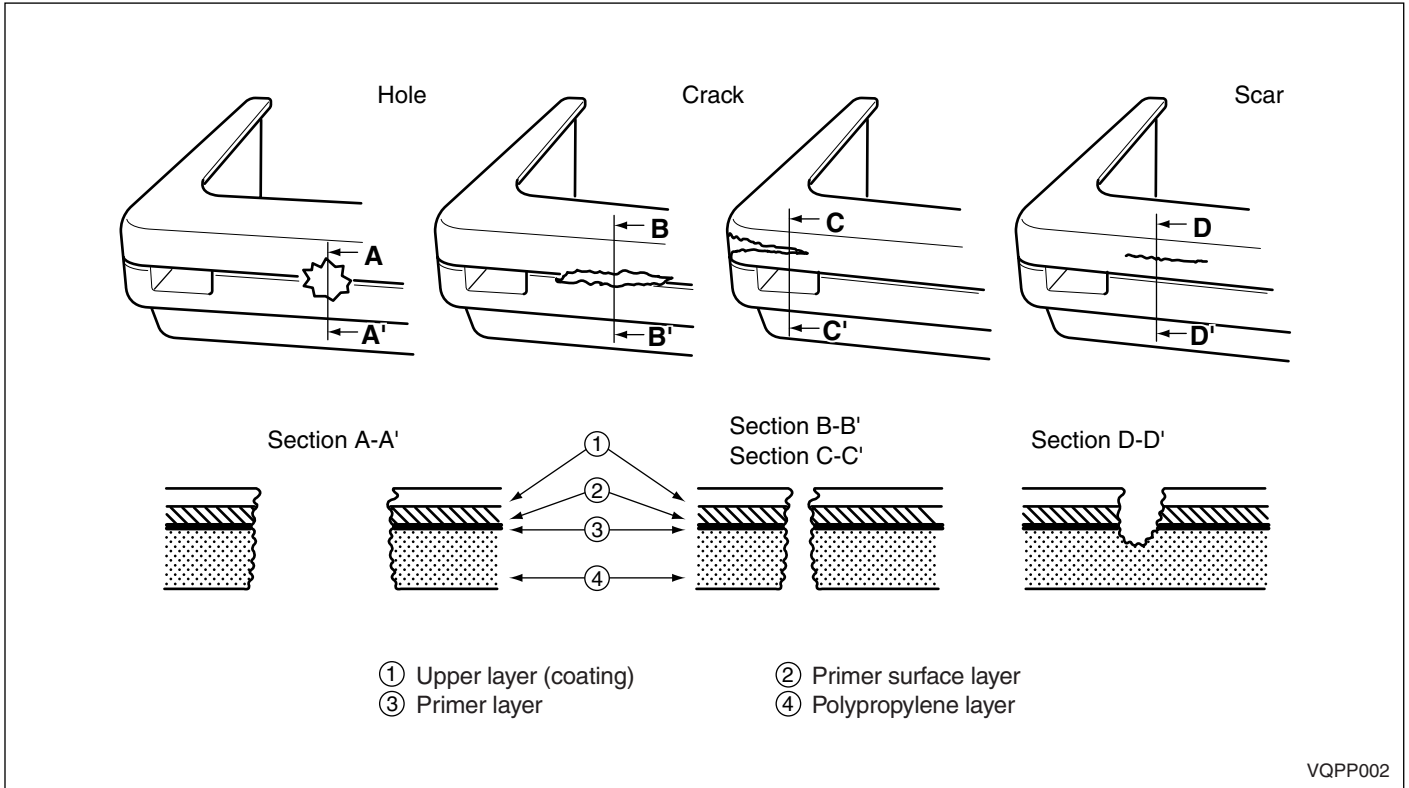

VQPP002

1. Rough cut the damaged area 45° using a knife and then sand the angle smooth.

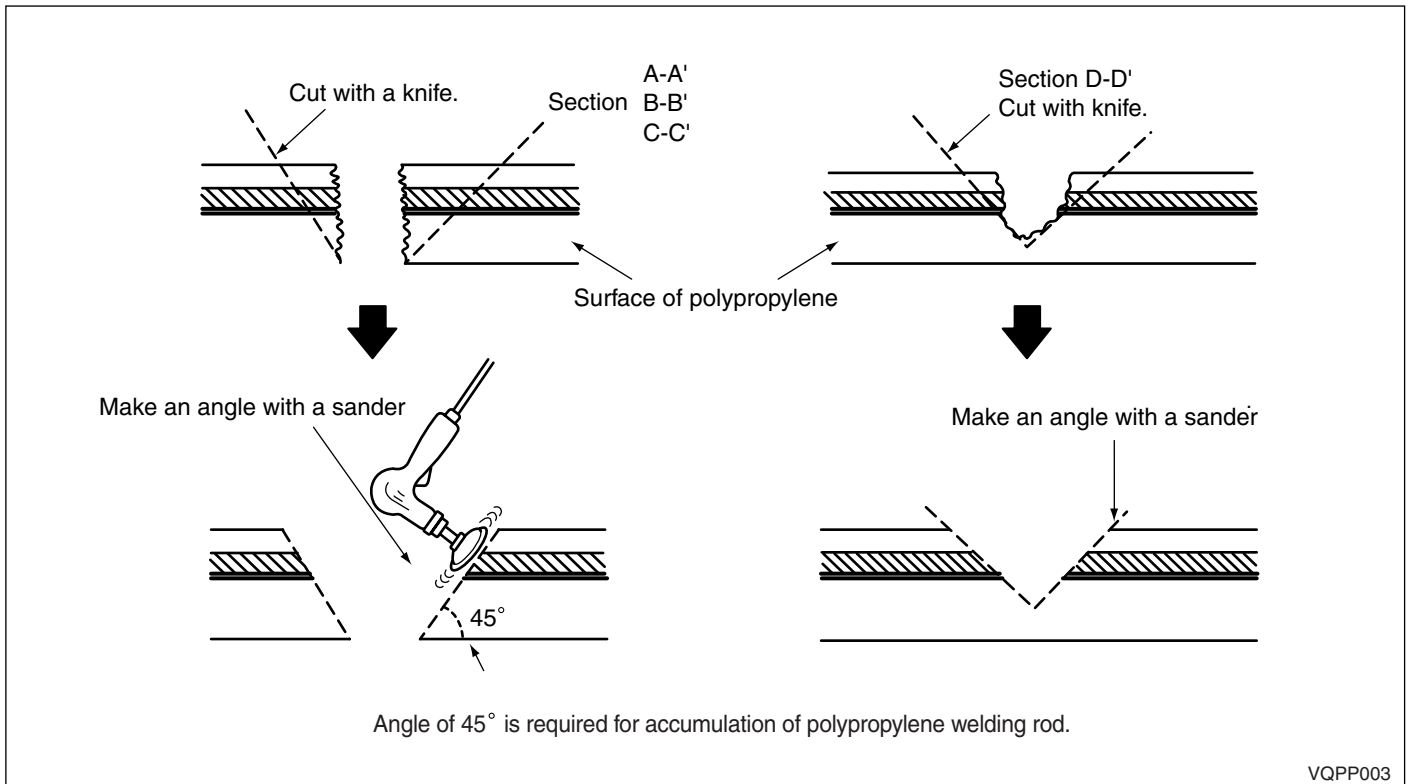

VQPP003

2. Welding damaged area
 - a) To repair cracked area, melt the area using a heat gun and attachment.

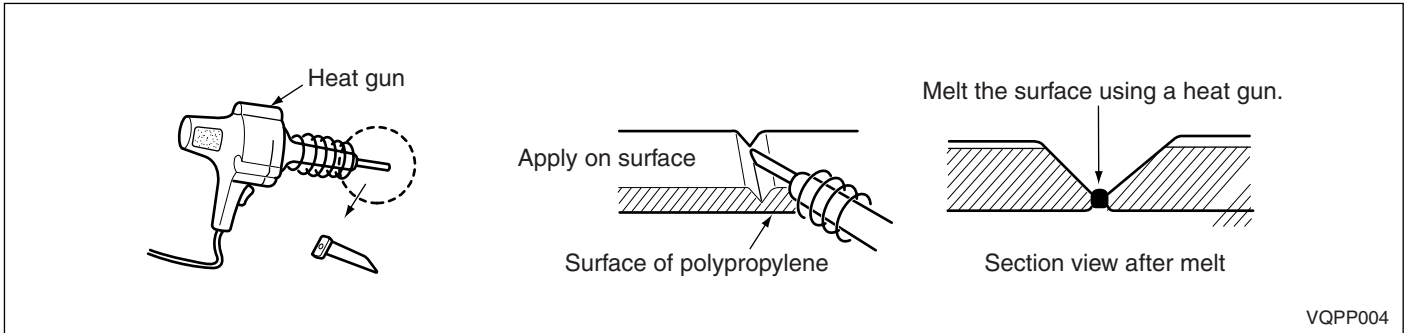

- b) To repair a hole, remove oil from the damaged area and apply aluminum tape to the rear side of the damaged area.

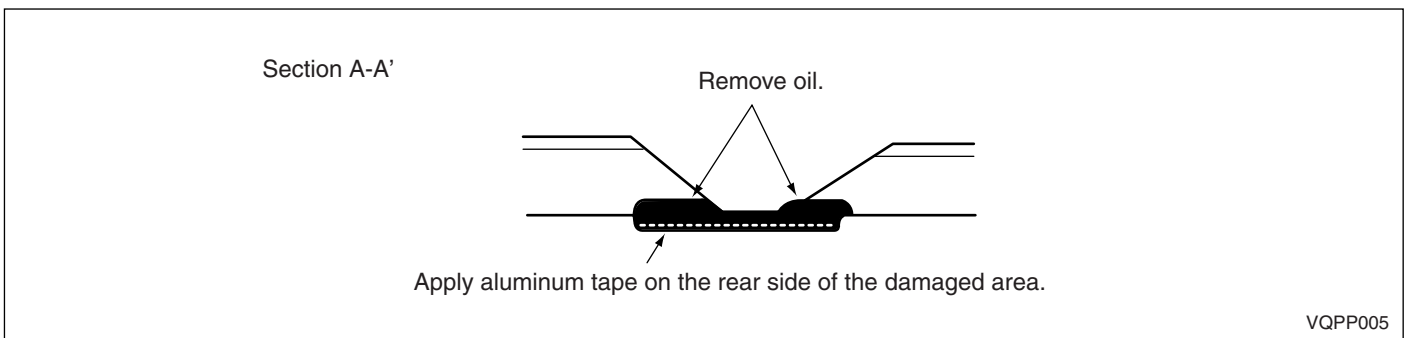

3. Melt polypropylene welding rod using a heat gun and fill in the cracked area.

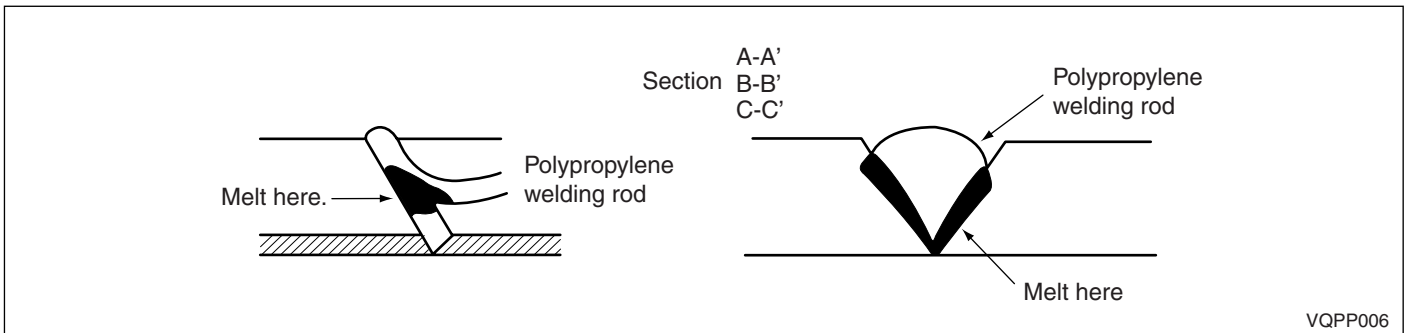

NOTE

- Heat and melt the area indicated.
- Melt the welding rod carefully so that it does not over-melt. If the welding rod over-melts like jelly, the welding strength will deteriorate.
- Use the heat gun 0.4~0.8 in. (10~20 mm) away from the repair area to be welded. Welding rod should not move until the welded area is cooled.

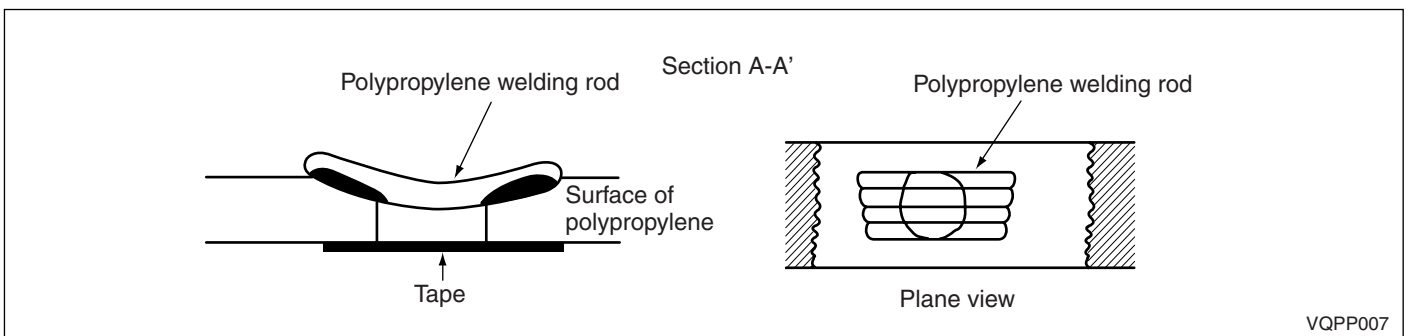

4. Grind polypropylene surface carefully. It melts easily due to the heat generated by friction. If melted, remove that area. Also, grind the area where solvent is to be applied.

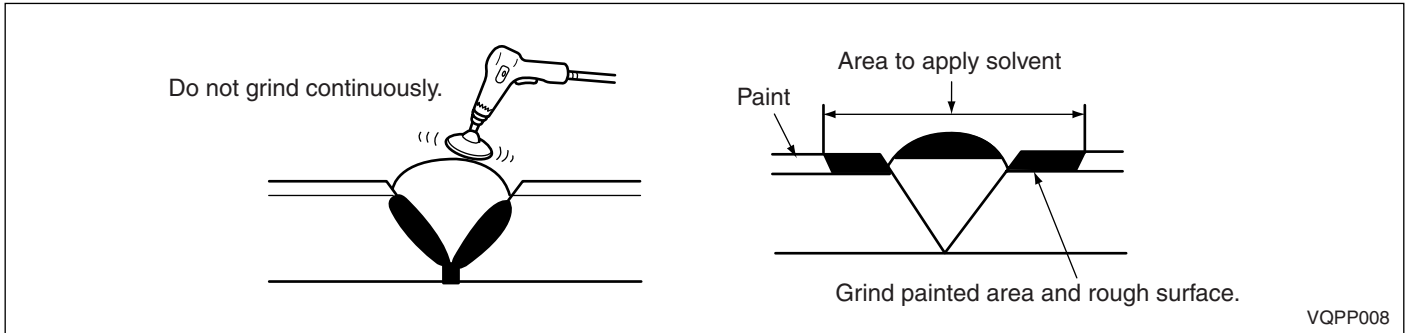

5. Apply polypropylene primer evenly with a brush over an area wider than the area to be repaired. Dry it at 20°C (68°F) for more than 10 minutes.

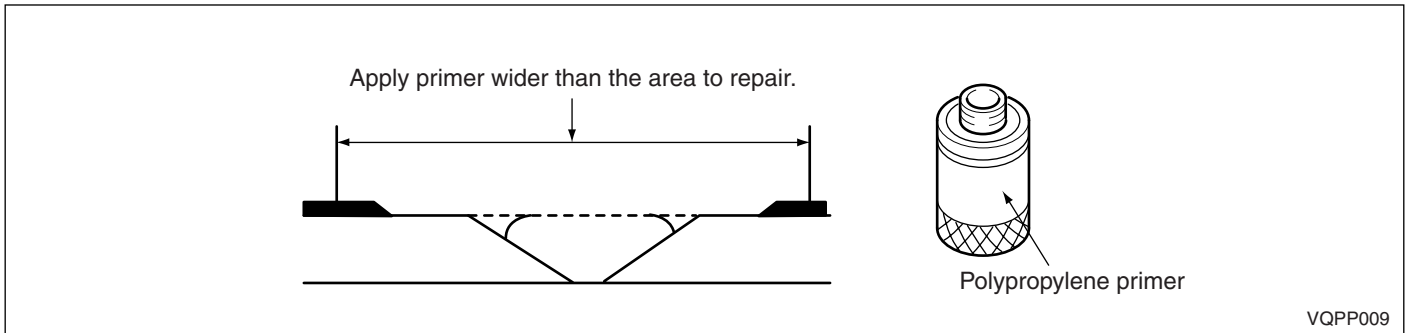

6. Mix main filler material and hardener at a ratio depending on paint specifications. Mix filler material and apply over the damaged area.

NOTE

- Mix main filler material and hardener so that no bubbles are made.
- Work immediately after mixing filler material because the filler material hardens quickly (in about 5 minutes).
- Dry it at 20°C (68°F) for about 30 minutes before sanding.

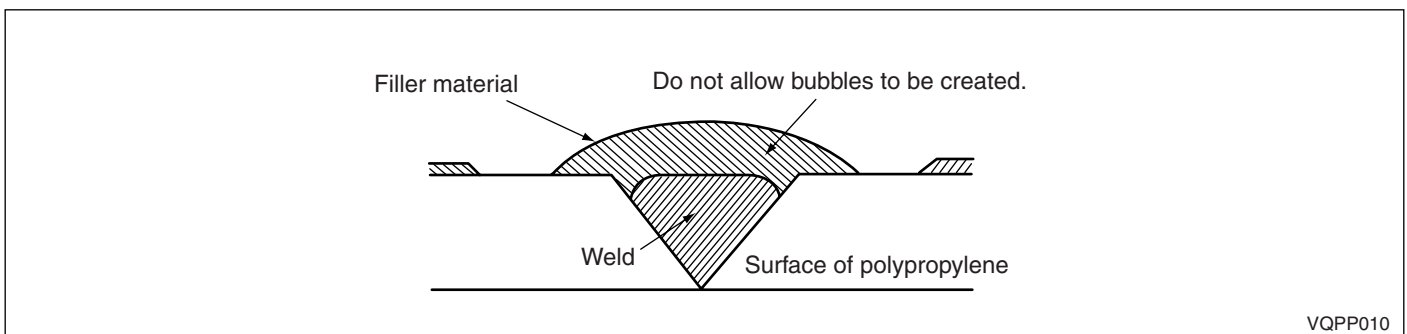

- Filler material consists of two types of epoxy. When the filler material hardens, you will have a desirable finish with flexibility like polypropylene.
- Use only filler material designed for use on polypropylene bumpers.

7. Sand the damaged area with sandpaper using #180~#240 grit paper.

 **NOTE**

- The surface will not be even if excessive force is applied during sanding.
- If there is fuzz in the damaged area, heat it a little bit with a heater gun and melt it.

8. Degrease the painted surface.

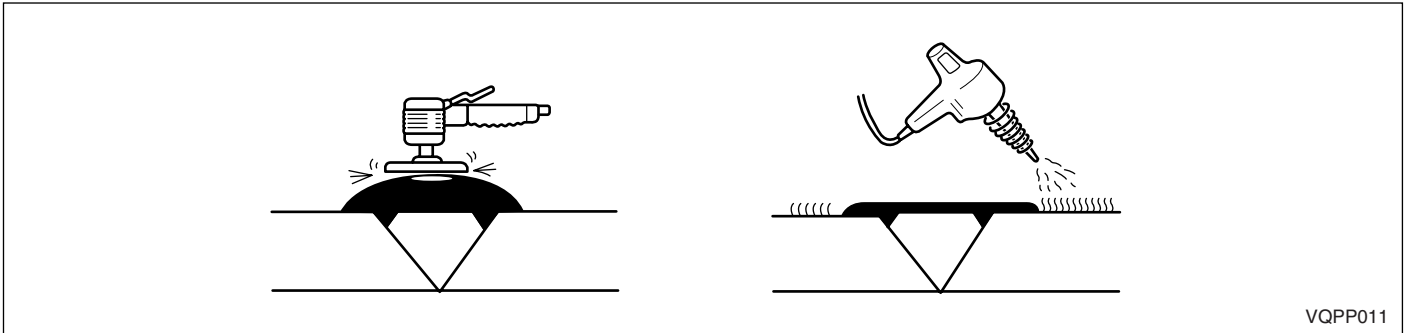

9. Mix polypropylene primer and hardener at a ratio depending on paint specifications. Spray polypropylene primer on the surface of the damaged area and the bumper.

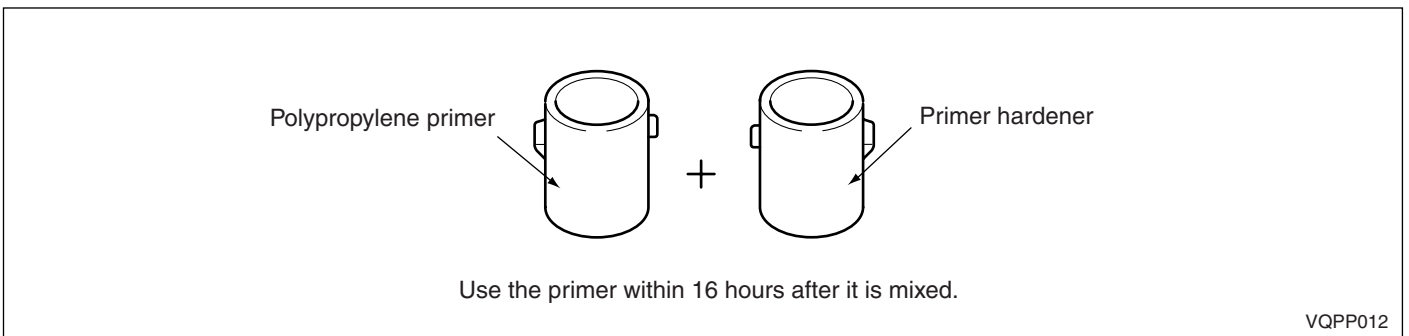

10. Apply polypropylene primer.

 **NOTE**

Use only water to clean after applying polypropylene primer. Solvent, if used, will melt the primer.

11. Lightly sand the sprayed area using a primer a sandpaper(#400~#600).
The polypropylene surface should not be exposed.(Either wet sanding or dry sanding is all right.)
12. Use agent(TCE(Tri Chloro Ethane) degreasing material) to remove any grease or oil, and wipe the finished surface of the bumper quickly with a clean cloth.

 **NOTE**

- The painting method for the polypropylene bumper is the same used to paint the urethane bumper.
- Therefore, use urethane primer only on urethane bumpers and polypropylene primer on polypropylene bumpers.

13. Air dry at 20°C(68°F) for about 8 hours, or dry in 60°C(140°F) for about 2 hours.
(Since drying time varies according to the type of paint used, follow paint manufacturers directions for drying times.)

 **NOTE**

Air dry if possible. Forced drying may create air bubbles on the top layer.

FRONT & REAR BODY

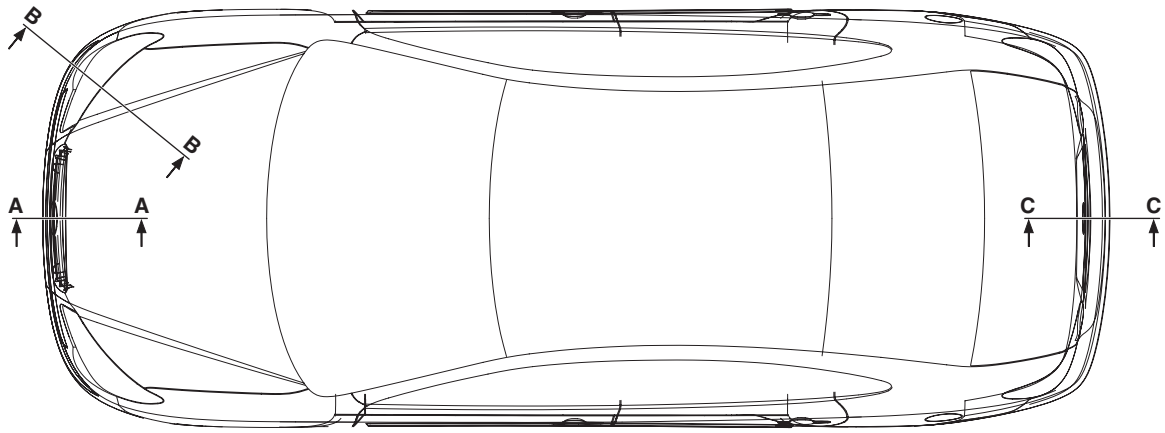

[TOP VIEW]

BHDBC6101

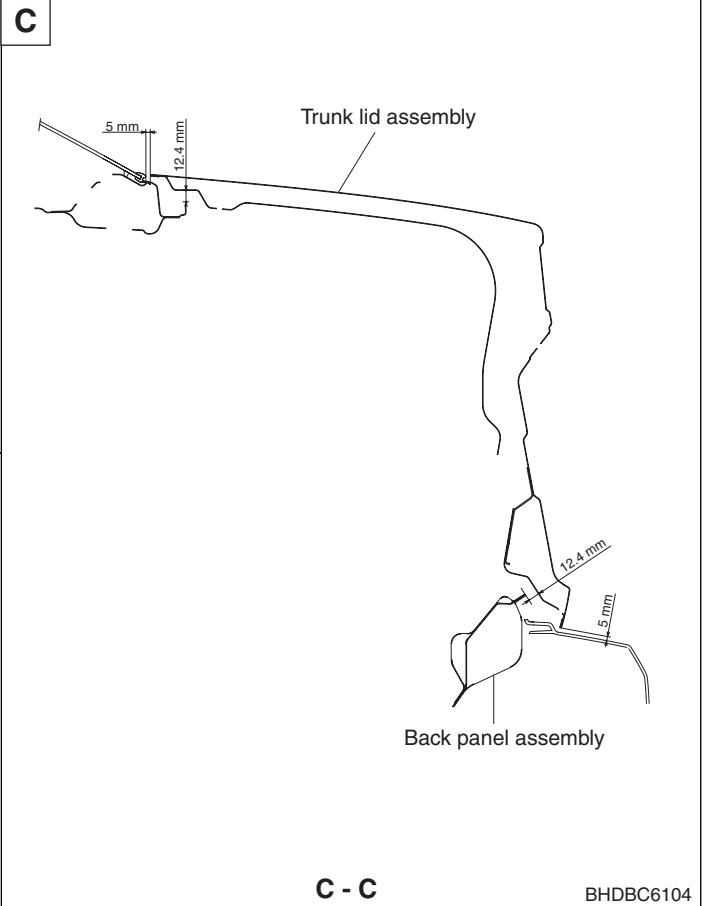
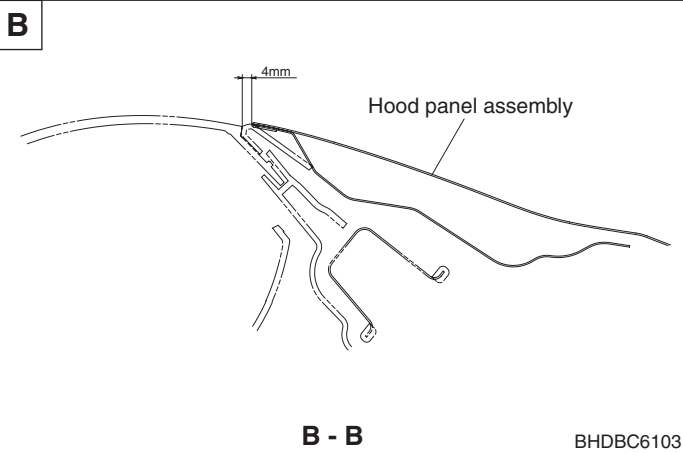
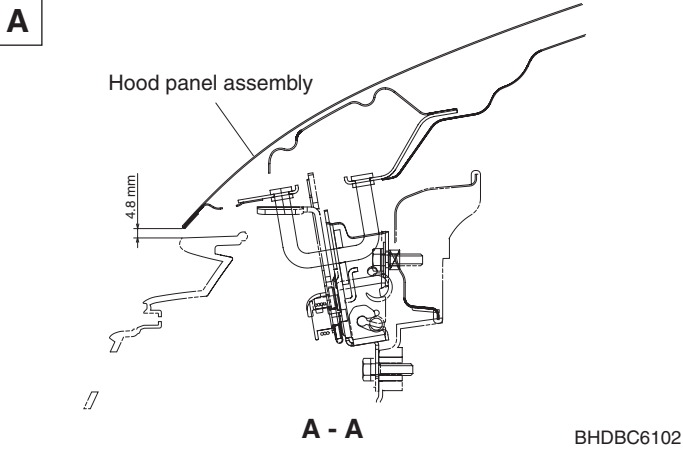

SIDE BODY

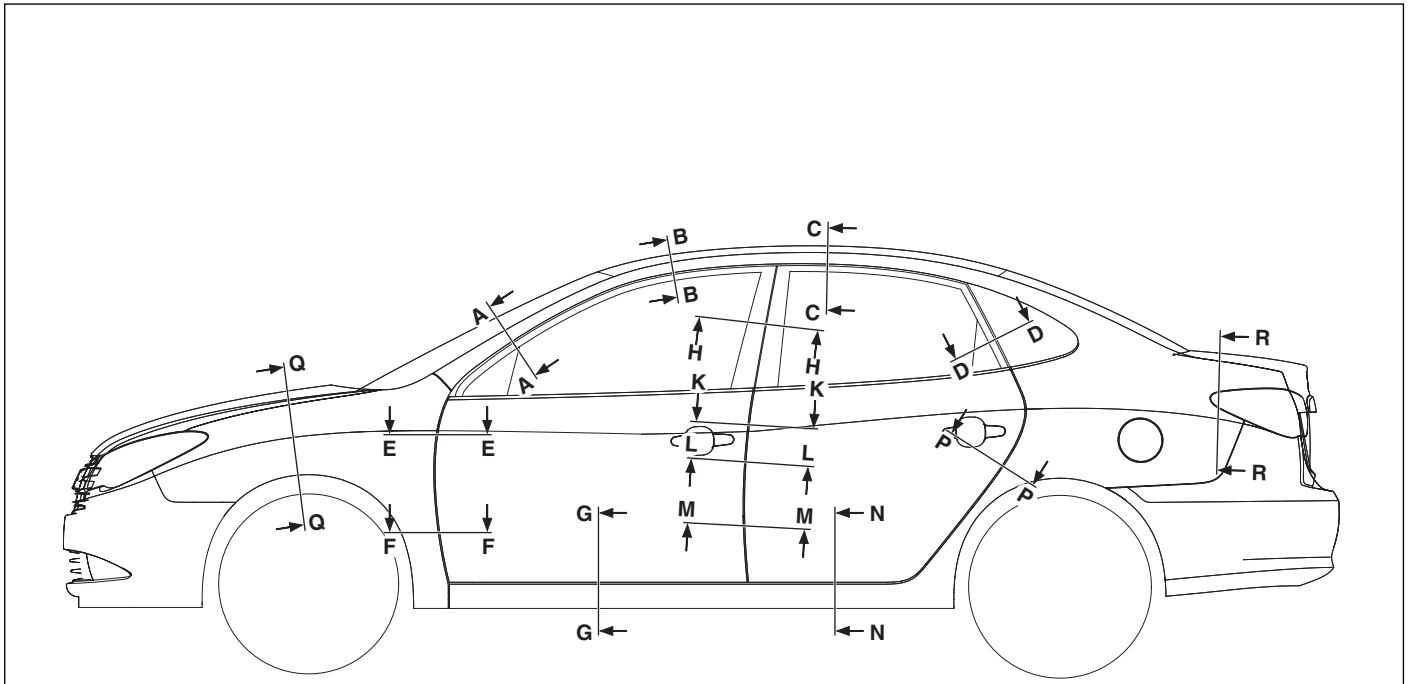

[SIDE VIEW]

BHDBC6201

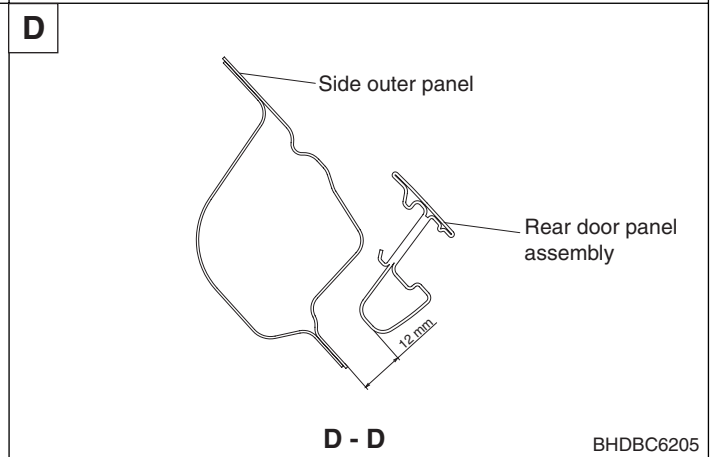
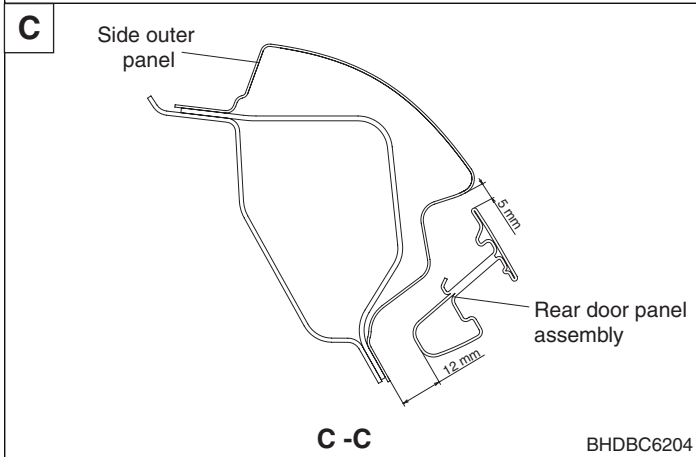
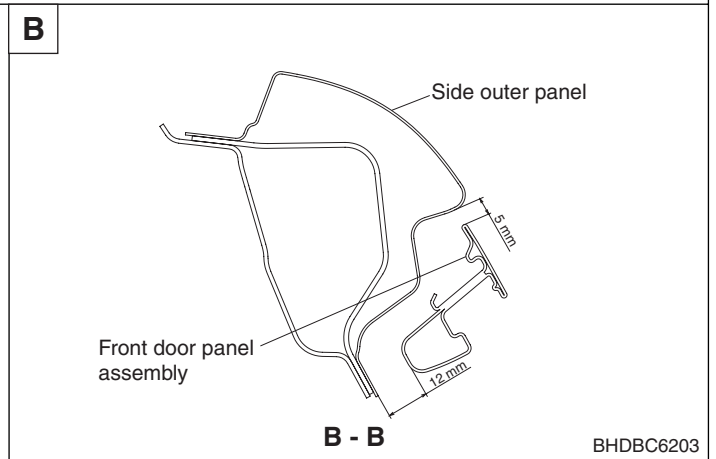
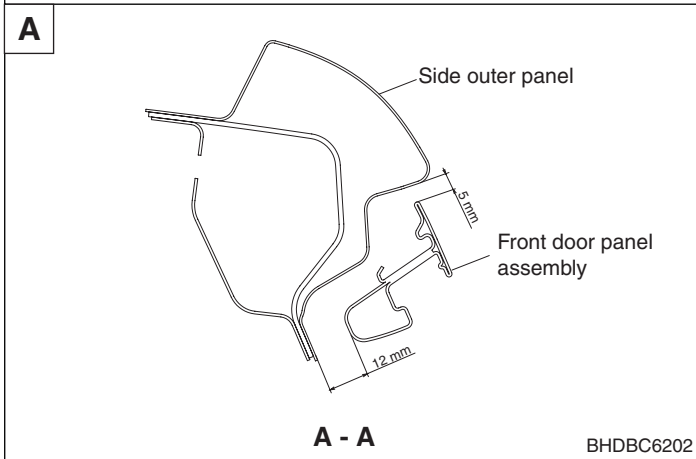

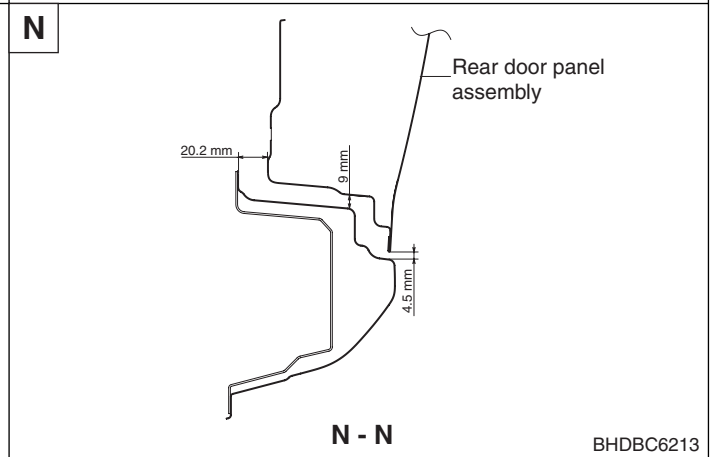
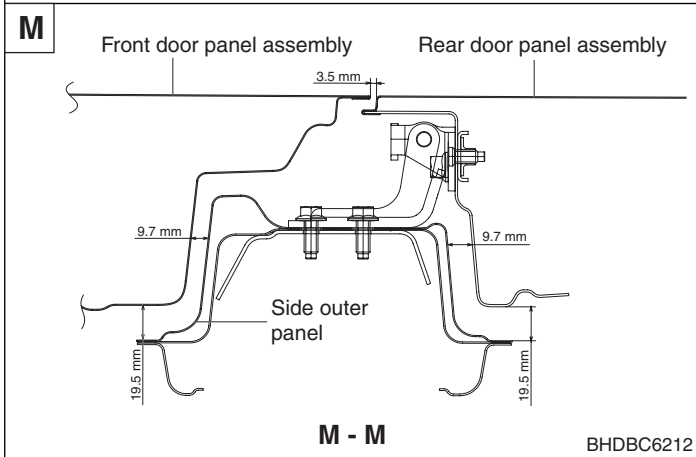
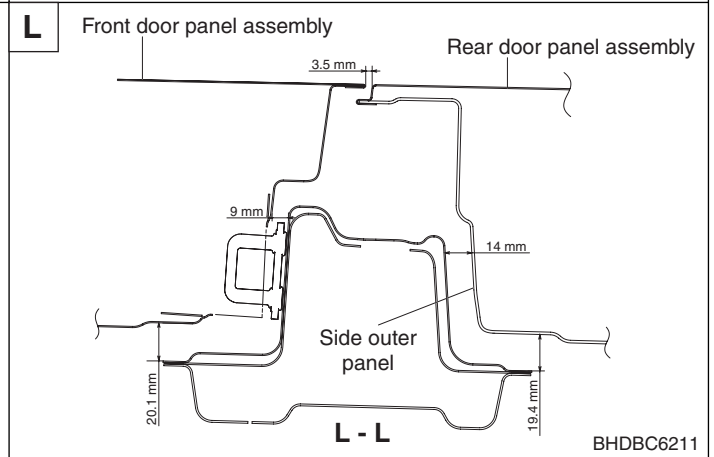
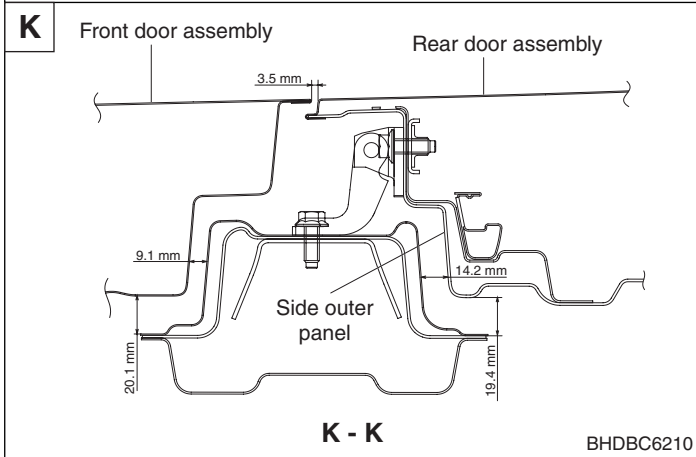
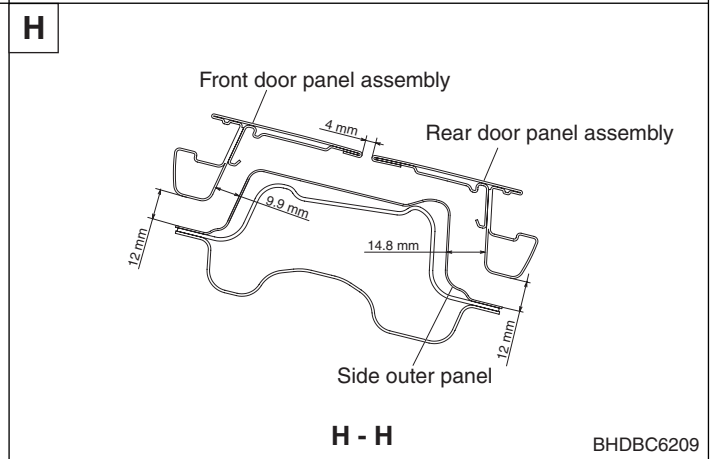
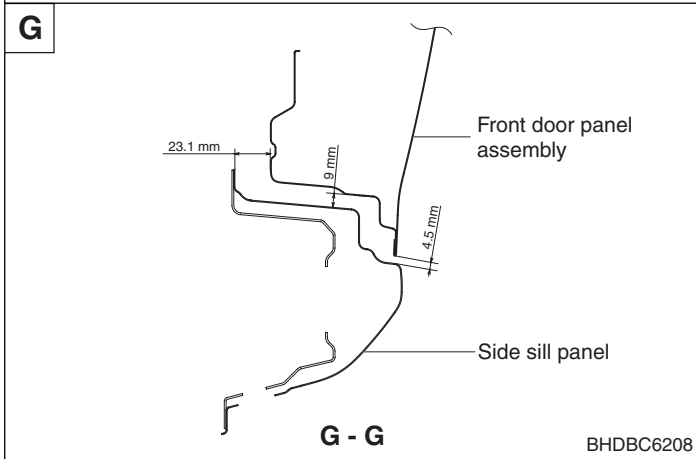
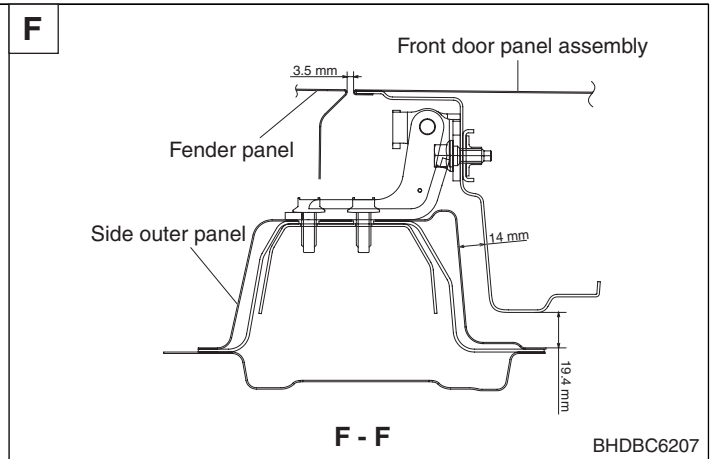
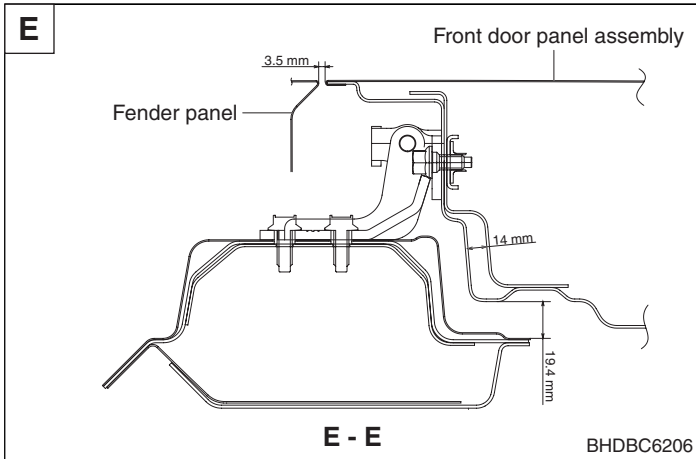

FRONT & REAR BODY

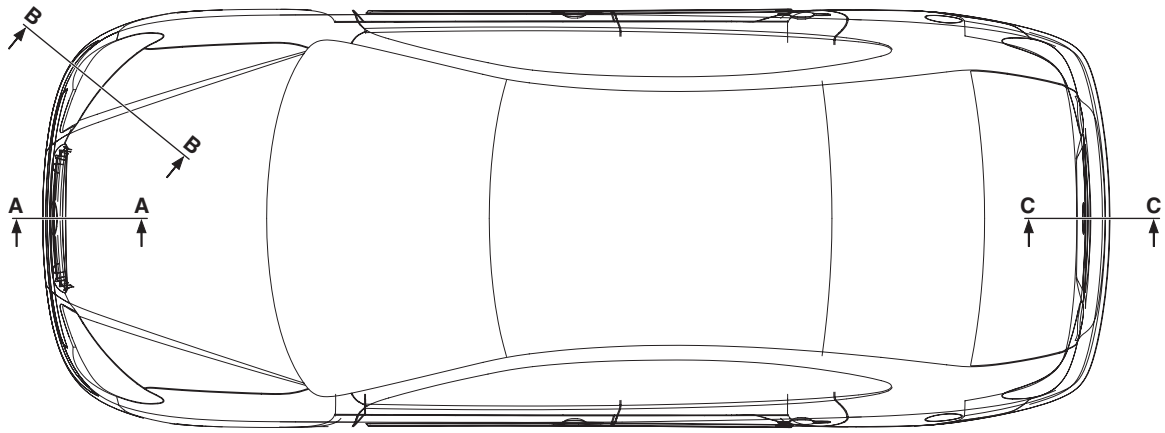

[TOP VIEW]

BHDBC6101

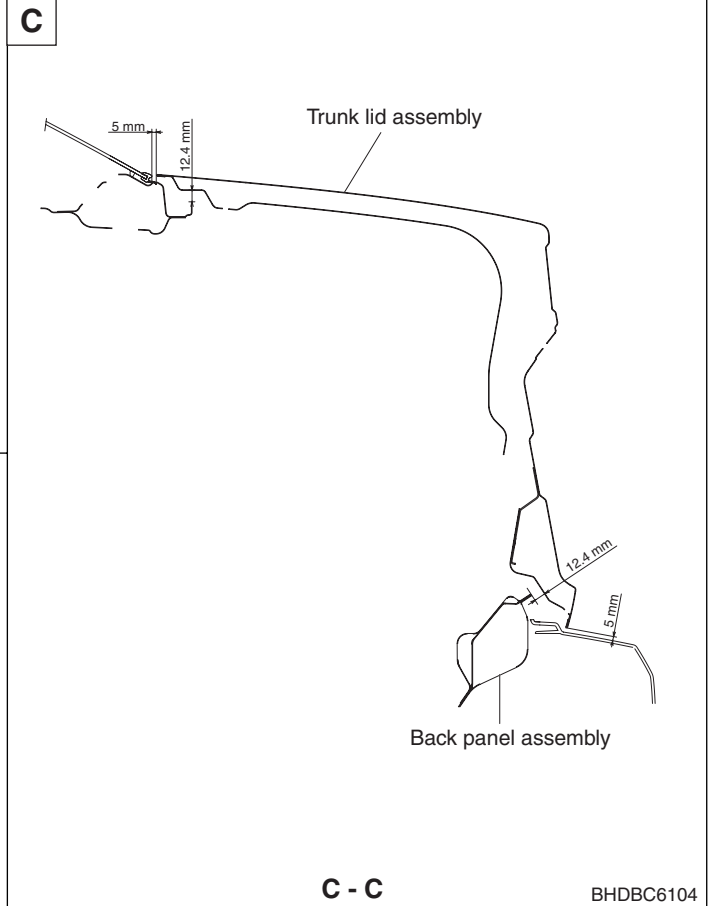
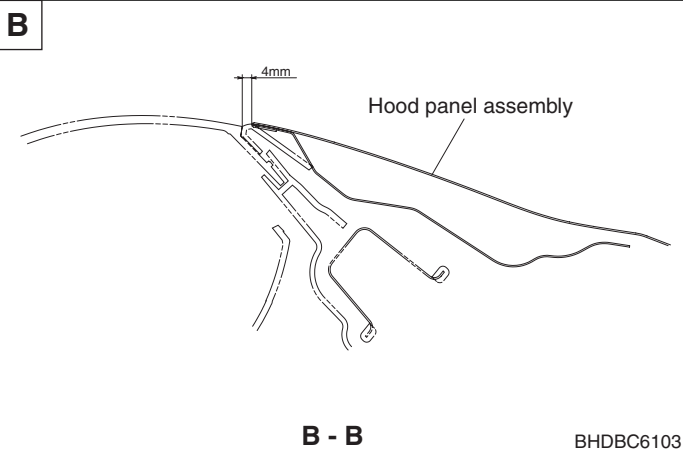
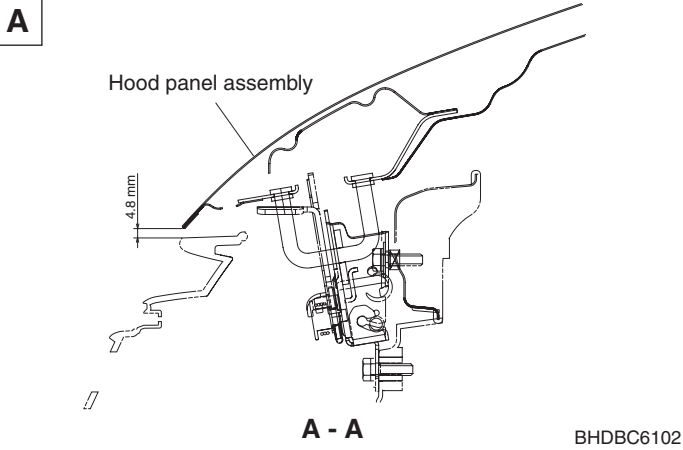

SIDE BODY

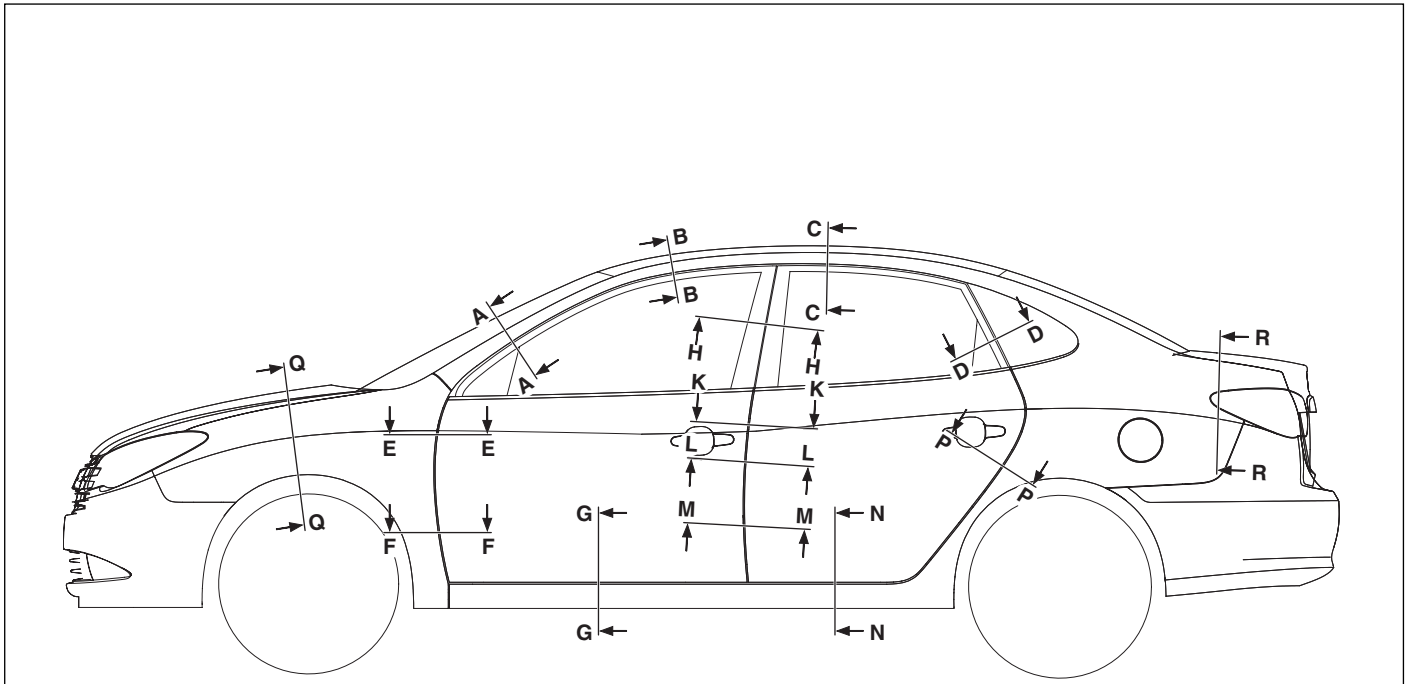

[SIDE VIEW]

BHDBC6201

