

# DuPont Performance Services Structural Repair



**EDUCATION**



**CONSULTING**



**PERFORMANCE  
GROUPS**



**TOOLS**



**PERFORMANCE  
ALLIANCE**

Version 1.0 — September 2011

**DUPONT CONFIDENTIAL**

The DuPont Oval logo, DuPont™, The miracles of science™ and all products denoted herein with ™ or © are trademarks or registered trademarks of E.I. du Pont de Nemours and Company. DuPont Trademarks may not be used in connection with any product or service that is not a DuPont product or service.



*The miracles of science™*

# Structural Repair Menu

This document includes information on the following topics:

- Set-up and Measure
  - Structural Repair Position Statements
-

# Frame Set-up and Measure

***Question 1: Is it required to measure/identify structural damage in order to restore the vehicle to pre-accident condition?***

***The following items are included as justification:***

- *Information Provider P-page Documentation (2 pages)*
-



### R&R (Remove & Replace)

Remove old part, transfer necessary items to new part (unless otherwise noted in Labor Procedure pages), replace and align. Does not include Suspension/Wheel alignment.

### STRUCTURAL COMPONENT IDENTIFICATION

Structural component identification information as presented in I-CAR Enhanced Delivery programs.

Welded structural parts can be made from different types of metal. Identification is not based on metal type. Replacement requires specific measuring equipment and vehicle dimensions must be correct. If improperly repaired, road performance and/or crashworthiness of the vehicle may be affected. Airbag deployment may also be affected.

Welded structural parts on a unibody vehicle typically include:

- APRONS/STRUT TOWER
- CENTER PILLAR
- CORNER PILLAR
- FRONT RAIL
- HINGE PILLAR
- LOCK PILLAR
- RADIATOR CORE SUPPORT
- REAR RAIL
- REAR STRUT TOWER
- ROCKER PANEL
- SUSPENSION CROSSMEMBER
- UPPER RAIL

### STRUCTURAL COMPONENT IDENTIFICATION - Continued

Welded structural parts of the body on a body-over-frame vehicle typically include:

- APRON ASSEMBLY
- CAB CORNER (PICK-UP)
- CAB BACK PANEL (PICK-UP)
- CENTER PILLARS
- CORNER PILLARS
- FRONT RAIL
- HINGE PILLARS
- LOCK PILLARS
- RADIATOR CORE SUPPORT
- REAR RAIL
- ROCKER PANELS
- UPPER RAIL

Some parts that are bolted, bonded or welded may add structural integrity to a vehicle's body. These parts may be made from different types of materials and vehicle dimensions must be correct before replacement. If improperly repaired, road performance and/or crashworthiness of the vehicle may be affected. Air bag deployment may also be affected.

Parts that may add structural integrity to a vehicle's body may include:

- COWL ASSEMBLIES
- DASH PANEL
- ENGINE CRADLE (bolt-on)
- FLOOR PANEL
- IMPACT BAR (bolt-on)
- PERIMETER FRAME
- QUARTER PANEL
- RADIATOR CORE SUPPORT (bolt-on)
- REAR BODY PANEL
- ROOF PANEL
- STATIONARY GLASS (urethane bonded)

## Additions to Labor Times (continued)

- **ANTI-CORROSION RUST RESISTANT MATERIAL:** Remove and/or apply weldable zinc primers, wax, petroleum based coatings, undercoating or any type of added conditioning.
- **BROKEN GLASS CLEAN UP**
- **DETAIL:** Clean vehicle to pre-accident condition.
- **DRAIN & REFILL:** Fuel (see fuel tank)
- **ELECTRONIC COMPONENTS:**
  - Time to remove and install as necessary; includes wiring and/or wiring harness and computer module.
  - Time to reset memory code function (example: seat position, radio presets) when battery has been disconnected to perform repairs.
  - Time to complete computer relearn procedures for proper operation of vehicle systems (example: power sunroof, power window) when battery has been disconnected to perform repairs.
- **FABRICATION:** Fabrication of reinforcements or inserts (new component not cut or manufactured from existing or new part, but from raw stock).
- **FRAME SET-UP:** See Definitions section page P2.
- **FREE UP PARTS:** Time necessary to free up parts frozen by rust or corrosion.
- **MEASURE AND IDENTIFY:** Structural damage by comparing vehicle underbody, underhood, and upperbody reference points to accepted, OEM-based dimension specifications to identify damage to unibody vehicles.

- **PLUG AND FINISH HOLES:** Time to plug and finish unneeded holes on parts being installed.
- **REPAIR OR ALIGN:** Parts adjacent to parts being replaced.
- **REWORK PARTS:** To fit a particular year or model (example: cutting holes for lamps, modifying a radiator support).
- **TAR AND GREASE:** Removal of these or any other materials that would interfere with operation.
- **TRANSFER TIME:** For welded, riveted or bonded brackets, braces or reinforcements from old part to new part.

## Unibody Structural Components

Unibody structural components are parts which support the weight of the vehicle and absorb the energy of the impact as well as road shock. These components are designated with the letter "s" in the text. The components are the radiator support, front and rear unirails, apron and wheelhouse (strut type) assemblies, rocker panel assemblies and suspension crossmembers. Body pillars, while not primary load-bearing structures, also require special treatment and are considered structural components.

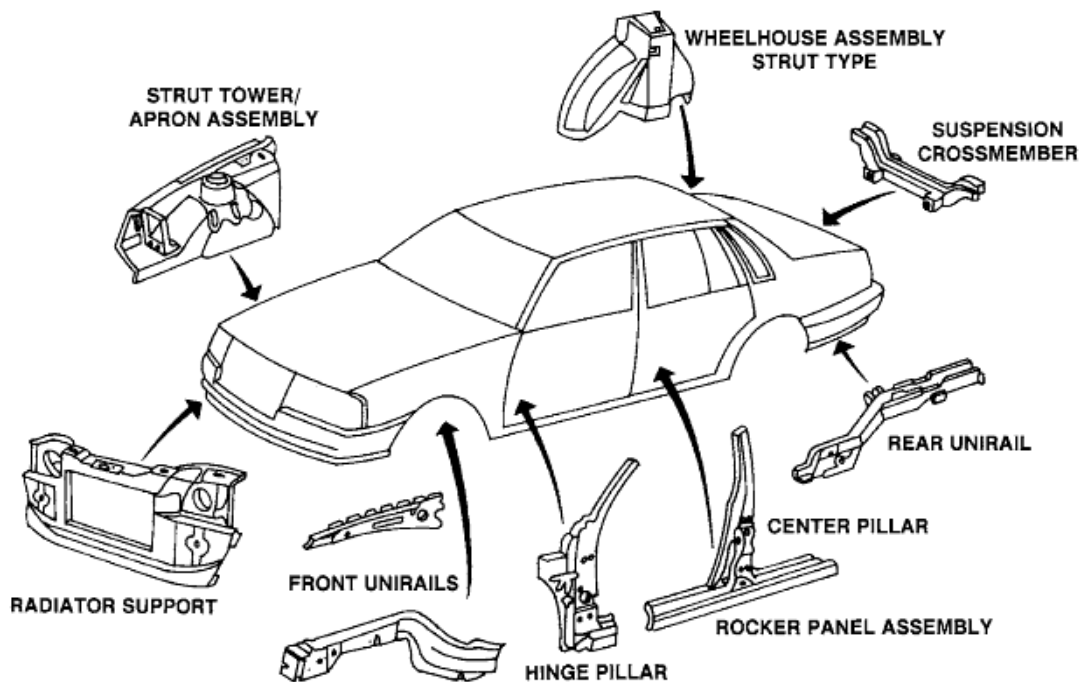

Component identification and illustration  
courtesy of TECH-COR, Inc.

Rev. 01-07

# Frame Set-up and Measure

**Question 2: Is frame set-up and measure included in any other labor operation?**

***The following items are included as justification:***

*1. According to the Information Providers, measuring and identifying structural damage is not included in any other labor operation.*

- *Information Provider P-page Documentation (3 pages)*
  - *DEG*
  - *ASA Not-Included Lists*
  - *SCRS*
-

## Section 4-2 Labor Exclusions

### Labor Exclusions – continued

- Repair, fitting, trimming, or modification of recycled parts.
  - Replace labor does not include additional labor to repair the replaced panel and or adjacent panels which may become distorted, burned or damaged by welding, drilling, grinding and straightening.
  - Reset of electronic components (e.g., airbags, computers, modules, clock, radio, tire pressure monitors, adaptive cruise control, etc.). (Standard Manual Entry M67 is available).
  - Restoration of corrosion-protective coatings (e.g., galvanizing, zinc coatings, E-coat 'equivalent', and other like materials). (Standard Manual Entry M14 is available). For more detailed information, see Refinish section.
- Setup of a vehicle on a frame machine, dedicated bench, or other measuring / straightening devices. Pulling time is not included (Standard Manual Entry M31 is available).
- Steam cleaning of or rust removal from fuel tanks.
  - Test drive to relearn system.
  - Transfer of attached items from original parts to recycled parts.
  - Wheel balancing (Standard Manual Entries M22 through M25 are available).

\*Any printed copy of this document may not contain the most current information. For the latest version, please refer to the Database Reference Manual accessed through the Help Menu in the current release of Audatex Estimating, PenPro or Shoplink. The current version of the Database Reference Manual may also be found at [www.training.audatex.us](http://www.training.audatex.us). <<http://www.training.audatex.us>>

# GUIDE TO ESTIMATING



## LABOR PROCEDURES

### LABOR TIME LISTINGS

All operation times are listed in hours and tenths of an hour. A time listed as 3.5 indicates three and one half hours.

### LABOR TIME PREMISE

The times reported in this publication are to be used as a GUIDE ONLY. Reported times include normal align procedure to insure proper fit of the individual new part being replaced. Reported times include tube/padded application of OEM caulking and seam sealers on welded replacement panels. Sprayable seam sealer equipment requires preparation and adjustment before application and is NOT INCLUDED IN LABOR TIME.

Times do not apply to vehicles with equipment other than that supplied by the vehicle manufacturer as standard or regular production options. If other equipment is used, the time may be adjusted to compensate for the variables. Removal and replacement of exchanged or used parts is not considered. If additional aligning or repair must be made, such factors should be considered when developing the estimate. Items not listed under the INCLUDED/DOES NOT INCLUDE heading for any given procedure have not been considered in the estimated work time development for that procedure, unless specified by a footnote. **All included/not included items for labor procedures listed between pages G10 and G33 are for component R&R and R&I procedures unless otherwise indicated in operation heading.**

OPERATION TIMES LISTED ARE BASED ON NEW UNDAMAGED PARTS INSTALLED ON NEW UNDAMAGED VEHICLES AS INDIVIDUAL OPERATIONS. TIME HAS NOT BEEN CONSIDERED FOR ALIGNMENT PULLS, DAMAGE-RELATED ACCESS TIME, DAMAGED, USED, REMANUFACTURED OR AFTERMARKET PARTS. SOME OPERATION TIMES ARE APPLICABLE AFTER BOLTED, ATTACHED OR RELATED PARTS HAVE BEEN REMOVED. REFER TO SPECIFIC FOOTNOTES ATTACHED TO OPERATION TIME LISTING.

#### LABOR TIME DOES NOT INCLUDE:

##### SPECIAL NOTATION:

The items listed below apply to all labor procedures.

- A/C System, Evacuate and Recharge
- Aftermarket & OEM accessories
- Alignment, check or straightening related parts
- Alignment check of front or rear suspension/steering
- Anticorrosion material restoration/application
- Battery D&R/recharge
- Brackets & braces transfer
- Broken glass removal or clean up
- Brakes, bleed and adjust
- Caulk (non-OEM), sound insulate or paint inner areas
- Clean up or detailing of vehicle prior to delivery
- Computer control module D&R/relearn
- Conversion Vans (special components, equipment and trim)
- Cutting, pulling or pushing collision damaged parts for access
- Damaged or defective replacement parts
- Drain & refill fuel tank
- Drilling, modification or fabrication of mounting holes
- Fabricate templates, reinforcing inserts, sleeves or flanges
- Filling, plugging and finishing of unneeded holes in new parts
- Information label installation
- Material costs
- Pinch weld clamp damage repair
- Refinishing

### LABOR TIME PREMISE - Continued

- Reset electronic memory functions after battery disconnect
- Road test vehicle
- Rusted, frozen, broken or corrosion damaged components or fasteners
- Scan tool clear/reset electronic module
- Scan tool diagnostics
- Straighten or align used, reconditioned or non-OEM parts
- **Structural damage diagnosis and vehicle set up time**
- Structural foam removal or application
- Test panel/spray caulk
- Undercoating, tar or grease removal
- Unprimed bumpers, removal of mold-release agents
- Waste disposal fees (all types)
- Weld through primer
- Welded seam surface finishing finer than 150 grit sandpaper
- Wheel or hub cap locks R&I

### FRONT BUMPER ASSEMBLY - R&I ALL TYPES

#### INCLUDED:

- Align to vehicle
- Face bar/bumper cover assembly R&I

#### DOES NOT INCLUDE:

- Air bag sensor
- Battery
- Emblems & nameplates
- Energy absorber, all types
- Lamp aiming
- Lamps (when not mounted in bumper)
- Moldings & impact strip
- Stripe tape, decals or overlays
- Valance panel/spoiler (when not mounted to bumper)

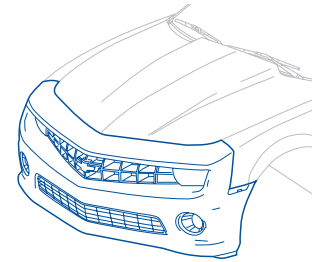

### FRONT BUMPER - R&R FACE BAR TYPE

#### INCLUDED:

- Align to vehicle
- Emblem & nameplate
- Face bar R&I
- Guard
- Guard cushions
- Molding & impact strip

#### DOES NOT INCLUDE:

- Air bag sensor
- Battery
- Distance sensor
- Energy absorber, if mounted to frame rail (all types)
- Lamp aiming
- Lamps (when not mounted in bumper)
- License plate/bracket
- Stripe tape, decals or overlays
- Valance panel/spoiler (when not mounted to bumper)

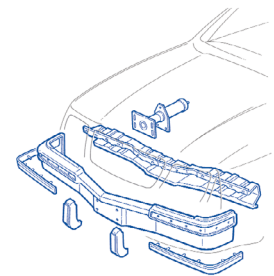



## Additions to Labor Times (continued)

- **ANTI-CORROSION RUST RESISTANT MATERIAL:** Remove and/or apply weldable zinc primers, wax, petroleum based coatings, undercoating or any type of added conditioning.
- **BROKEN GLASS CLEAN UP**
- **DETAIL:** Clean vehicle to pre-accident condition.
- **DRAIN & REFILL:** Fuel (see fuel tank)
- **ELECTRONIC COMPONENTS:**
  - Time to remove and install as necessary; includes wiring and/or wiring harness and computer module.
  - Time to reset memory code function (example: seat position, radio presets) when battery has been disconnected to perform repairs.
  - Time to complete computer relearn procedures for proper operation of vehicle systems (example: power sunroof, power window) when battery has been disconnected to perform repairs.
- **FABRICATION:** Fabrication of reinforcements or inserts (new component not cut or manufactured from existing or new part, but from raw stock).
- **FRAME SET-UP:** See Definitions section page P2.
- **FREE UP PARTS:** Time necessary to free up parts frozen by rust or corrosion.
- **MEASURE AND IDENTIFY:** Structural damage by comparing vehicle underbody, underhood, and upperbody reference points to accepted, OEM-based dimension specifications to identify damage to unibody vehicles.

- **PLUG AND FINISH HOLES:** Time to plug and finish unneeded holes on parts being installed.
- **REPAIR OR ALIGN:** Parts adjacent to parts being replaced.
- **REWORK PARTS:** To fit a particular year or model (example: cutting holes for lamps, modifying a radiator support).
- **TAR AND GREASE:** Removal of these or any other materials that would interfere with operation.
- **TRANSFER TIME:** For welded, riveted or bonded brackets, braces or reinforcements from old part to new part.

## Unibody Structural Components

Unibody structural components are parts which support the weight of the vehicle and absorb the energy of the impact as well as road shock. These components are designated with the letter "s" in the text. The components are the radiator support, front and rear uniraills, apron and wheelhouse (strut type) assemblies, rocker panel assemblies and suspension crossmembers. Body pillars, while not primary load-bearing structures, also require special treatment and are considered structural components.

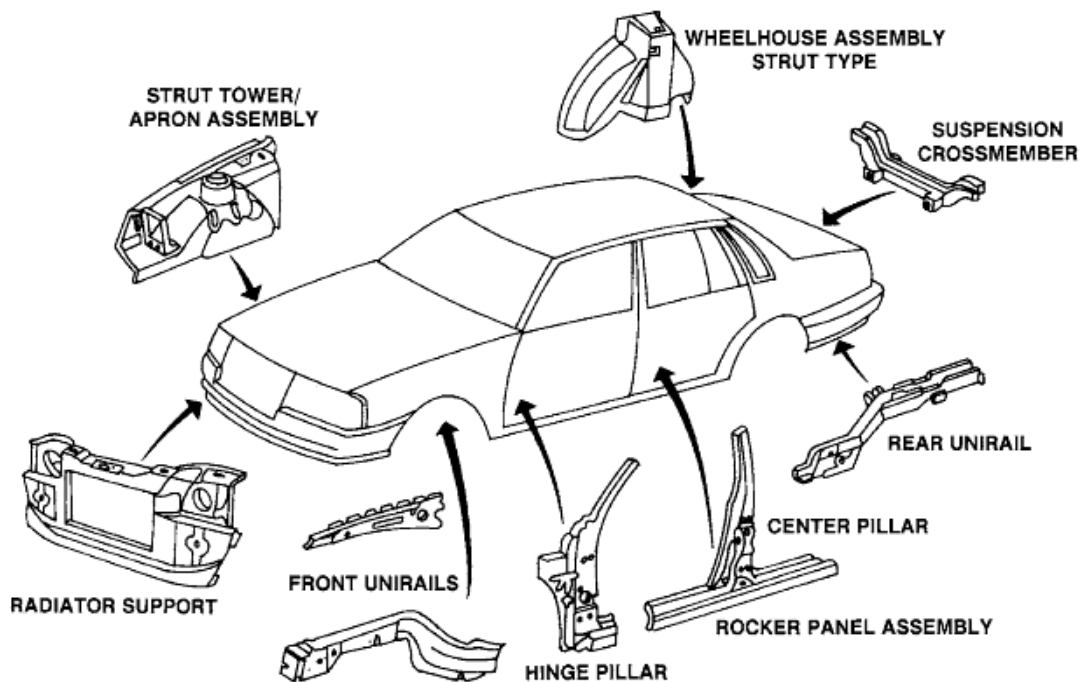

Component identification and illustration  
courtesy of TECH-COR, Inc.

Rev. 01-07

# Frame Set-up and Measure

**Question 3: Is there a pre-determined time in the database for frame set-up and measure?**

***The following items are included as justification:***

1. *None of the Information Providers provide times for set-up and measure for structural diagnosis or repair.*
    - *DEG – Issue # 547 and #643 (2 pages)*
-

Print Inquiry

<b>DEG DATABASE INQUIRY</b>							10/4/2011	
<b>Track_#</b>	<b>Estimating Platform</b>	<b>Inquiry Category</b>	<b>Year Make Model</b>	<b>Resolution Status</b>	<b>Origination Date</b>	<b>Submission Date</b>	<b>Resolution Date</b>	<b>Total Time to Resolve</b>
547	Audatex	- All Other	2000 TOYOTA TUNDRA	Resolved	7/9/2008 7:16:09 PM	7/10/2008 5:28:00 PM	7/10/2008 7:25:00 PM	01 Days
<b>Inquiry Description</b>				<b>Resolution Description</b>				
<p><b>Setup and Measure</b></p> <p>IssueSummary//SET-UP AND MEASURE FULL FRAME VEHICLE</p> <p>ProcedureSteps//WE HAVE TO REMOVE THE WHEELS TO PROPERLY CLAMP THIS VEHICLE DOWN ON OUR CAR-O-LINER FRAME RACK,I HAD CLICKED R&amp;I OFF EACH WHEEL.IT DID NOT COME UP INCLUDED,IT PAYS .1 PER WHEEL.</p> <p>SuggestedAction//IS THE R&amp;I OF THE WHEELS NCLUDED IN THE SET-UP OF A FULL FRAME VEHICLE? WHAT DOES "SETUP AND MEASURE" INCLUDE PER AUDATEX? DOES AUDATEX DEFINE A SPECIFIC CHARGE FOR SET-UP AND MEASURE OF FULL FRAME VEHICLES?</p>				<p><b>IP Explanation</b></p> <p>Audatex does not provide procedures or times for set-up and measure due to the wide range of measuring/straightening devices used in the automotive repair industry. . This is covered in the Database Reference Manual section 4-2 Labor Exclusions. "Setup of a vehicle on a frame machine, dedicated bench, or other measuring / straightening devices. Pulling time is not included (Standard Manual Entry M31 is available)". Therefore any operations that are included or not included in the Set-up and Measure would need to be determined by the estimate preparer and agreed upon by all involved parties.</p>				

Print Inquiry

<b>DEG DATABASE INQUIRY</b>								10/4/2011
Track_#	Estimating Platform	Inquiry Category	Year Make Model	Resolution Status	Origination Date	Submission Date	Resolution Date	Total Time to Resolve
643	Mitchell	- Procedure Page Issue	2004 TOYOTA COROLLA	Resolved	8/15/2008 5:12:28 PM	8/18/2008 9:22:00 AM	9/3/2008 11:47:00 AM	12 Days
<b>Inquiry Description</b>				<b>Resolution Description</b>				
<p><b>Set Up And Measure</b></p> <p>IssueSummary//Can you please explain what is included in a Frame Rack Set Up and Measurement. Insurance company states that when setting up a electronics measuring system, that within what they have determined as a standard 2.0 set up and measure that it includes R&amp;I of exhaust, lower front shields, rocker mldgs.</p> <p>SuggestedAction//A statement from Mitchell International on what they state that is included in a 2.0 set up and measurement.</p>				<p><b>IP Explanation</b></p> <p>CUSTOMER CONTACTED 8/20/08</p> <p>MITCHELL DOES NOT OFFER LABOR TIMES FOR SET UP AND ANY TIME ALLOWED WOULD NEED TO BE ESTIMATED ON SITE. MITCHELL DOES OFFER A DEFFINITION THAT INCLUDES ITEMS THAT ARE NORMALLY INCLUDED IN SET UP, HOWEVER, THIS IS NOT TO SAY THAT OTHER ITEMS OR OPERATIONS MAY NEED TO BE PERFORMED AND ACCOUNTED FOR.</p>				

# Frame Set-up and Measure

## ***Question 4: What is it worth?***

**Answer:** Use the Frame / Unibody Thought-Provoking Questions and the Structural Set-up and Repair Calculator

***The following items are included as justification:***

- *Frame / Unibody Thought-Provoking Questions*
  - *Structural Set-up and Repair Calculator*
-

**Unibody Damage Condition Analysis**

If pulling Unibody\Frame "OVER": Indicate if Pulling to the Left or Right.

	FWD	UP	DOWN	OVER LEFT	OVER RIGHT
Rough Pull					
Left Front Rail Upper					
Right Front Rail Upper					
Left Front Rail Lower					
Right Front Rail Lower					
Left Front Strut Tower					
Right Front Strut Tower					
Left Front Apron (Skirt)					
Right Front Apron (Skirt)					
Core Support					
Front Lower Crossmember					
Front Floor Pan					
Front Spare Tire Well					
Left Front Windshield Post					
Right Front Windshield Post					
Front Upper Cowl					
Firewall					
Left Front Door Post Outer					
Left Front Door Post Inner					
Left Front Door Post Assly					
Left Front Upper Door Hinge					
Left Front Lower Door Hinge					
Right Front Door Post Outer					
Right Front Door Post Inner					
Right Front Door Post Assly					
Right Front Upper Door Hinge					
Right Front Lower Door Hinge					
Left Rear Upper Door Hinge					
Center Left Door Post					
Left Rear Lower Door Hinge					

	FWD	UP	DOWN	OVER LEFT	OVER RIGHT
Center Right Door Post					
Right Rear Upper Door Hinge					
Right Rear Lower Door Hinge					
Left Rocker Outer					
Left Rocker Inner					
Right Rocker Outer					
Right Rocker Inner					
Left Center Floor Pan					
Right Center Floor Pan					
Roof					
Left Quarter Panel					
Right Quarter Panel					
Rear Body Panel					
Rear Trunk Floor					
Rear Spare Tire Well					
Left Outer Wheelhouse					
Right Outer Wheelhouse					
Left Inner Qtr					
Right Inner Qtr					
Left Rear Rail					
Right Rear Rail					
Left Inner Wheelhouse					
Right Inner Wheelhouse					
Rear Package Tray					

- Mash Conditions
- Buckle Conditions
- Square Up Trunk Openings
- Square Up Lft Frt Door Openings
- Square Up Rt Frt Door Openings
- Square Up Lft RR Door Openings
- Set Up
- Prep Pinchwelds Before & After Clamps
- Computerize Measuring
- Diamond
- Twist

Sag

**What has to be R&I'd to mount clamps? (oil lines, A/C lines, wheels, etc.)**





Sag

**What has to be R&I'd to mount clamps? (oil lines, A/C lines, wheels, etc.)**



## Structural Set-Up and Repair Calculations

### Suggested Base Units of Repair

Enter Values below based on each Circumstance

	Conventional		Bench	
	Equipment		Equipment	
	Portable	Stationary	Universal	Dedicated



### OPERATION

Note: Units / time are variable

Position on Machine	0.2	0.2	0.2	0.2
Install Measuring System	0.5	0.5	0.5	1.0
Analyze Damage and Record	0.3	0.3	0.3	0.3
Anchor to Machine	0.5	0.5	0.5	0.5
Monitor Measurements During Repair	0.2	0.2	0.2	0.2
Remove from Machine and Clean-Up	0.2	0.2	0.3	0.3
<b>Operation Totals</b>	<b>1.9</b>	<b>1.9</b>	<b>2.0</b>	<b>2.5</b>

<b>0</b>

**Comments:**

### Conventional Frame

Is this a two-wheel or 4-wheel drive vehicle?

Insert Units / Times below



Damage Conditions	Recommended Repair Units	
Twist (Variable)		2.0
Mash	Each Mash	2.0
Sag	Each Rail	2.0
Sidesway	Each Rail	4.0
Diamond (Variable)	Minor	2.0
Buckles (Variable)	Each Buckle	1.0

<b>Totals</b>	<b>0</b>
---------------	----------

**Comments:**

### Unibody Structure

Insert Units / Times below



Damage Conditions	Recommended Repair Units	
Mash	Each Mash	1
Combination Sag & Sidesway	Each	(R) Upper 1.5 / (L) Upper 1.5
		(R) Lower 2.0 / (L) Lower 2.0
Twist / Widening (Variable)	Each	1
Pull Tower	Each Side (single pull)	1
Buckles (Variable)	Each Buckle	0.5
Pull Cowl or Pillars (Variable)	Each single pull	1
Pull Floor	1.0 each 6" first pull	1.0

<b>Totals</b>	<b>0</b>
---------------	----------

Note: Conjunctive Repairs	Deduct from Second Rail	Upper 1.0
	Deduct from Second Rail	Lower 1.0

<b>Subtract</b>	<b>0</b>
-----------------	----------

\* Structural labor only, additional bodywork may be necessary

\* Time for pulling rail prior to replacement does not include R&R.

<b>Grand Total</b>	<b>0</b>
--------------------	----------

# Structural Repair Position Statements Menu

Choose a Vehicle Manufacturer from the list below:

- Chrysler
  - Ford
  - Honda
  - Toyota / Lexus
  - Volkswagon
-

# Sectioning Position Statements - Chrysler

1. Chrysler Structural Repair Parts Usage – August 11, 2010
  2. Chrysler Use of Heat During Repair – August 11, 2010
-



# STRUCTURAL REPAIR PARTS USAGE

## CHRYSLER GROUP LLC POSITION

Chrysler Group LLC vehicles, systems and components are engineered, tested and manufactured to protect vehicle occupants based upon both government mandated and internal corporate requirements relative to durability, NVH (noise/vibration/harshness), occupant protection, and vehicle safety.

The overall structural integrity of the vehicle is dependent on its inherent design specifications. Sheet metal and glass are critical elements in the design of specific crush zones that allow the energy of a collision to be absorbed in a predictable way and maximize the effectiveness of the restraint system to protect the occupants. The use of parts not specifically designed and tested by Chrysler Group LLC may compromise the integral balance between these safety systems.

Only Authentic Mopar® Repair Parts and glass are designed, engineered, manufactured and tested to the Chrysler Group LLC internal and government mandated standards and are the only ones equivalent to the originally installed parts.

Chrysler Group LLC does not approve of or recognize structural repair procedures where Authentic Mopar Parts are not used for Chrysler, Jeep®, Dodge and Ram vehicles. Any repairs performed not using Mopar parts, and not following published repair guidelines and procedures, may expose current or future vehicle owners and occupants to unnecessary risk.

When restoring a collision damaged vehicle to pre-loss condition, consideration must be given to the following:

- All structural distortion has been identified and corrected using appropriate structural straightening equipment (“frame rack”) and a three-dimensional measuring system
- All damaged panels have been repaired or replaced
- All replaced panels provide the as-built structural equivalence and corrosion protection of the original panels
- Unless partial replacement procedures are documented in a Chrysler Group LLC publication, structural panels must be installed in their entirety – partial replacement or “sectioning” of panels may compromise vehicle structure
- Chrysler Group LLC does not support the use or re-use of any structural component which has been removed from a vehicle previously damaged, flooded, burned, scrapped or removed from use for any other reason—commonly referred to as “salvage parts.”
- While some salvage parts may “appear” equivalent, there can be dramatic differences in the design and functional characteristics which cannot be determined by a visual inspection and which could have a negative effect on the vehicle occupants in a future collision event.
- Salvage components may have been affected by crash impact loads, incorrect, improper or inadequate disassembly and removal procedures, weathering or environmental exposure outside of that expected during normal use.
- Salvage components are not traceable should a component recall be required in the future.

*This statement supersedes any previously released information by Chrysler Group LLC.*

Release Date: August 11, 2010



DODGE

CHRYSLER

Jeep

For more information, log on to [www.MoparRepairConnection.com](http://www.MoparRepairConnection.com).



# USE OF HEAT DURING REPAIR

## CHRYSLER GROUP LLC POSITION

**Chrysler Group LLC Service Engineering's position on the use of heat during collision repair is as follows:**

- Any damaged body panel or frame component, which is to be repaired, must be repaired using the "cold straightening" method. No heat may be used during the straightening process.
- During rough straightening prior to replacement, damaged panels or frame components may be heated to assist in body/frame realignment. This application of heat, if absolutely necessary, must be constrained to the parts which will be replaced and not allowed to affect any other components.

This "no heat" recommendation is due to the extensive use of high-strength and advanced high-strength steels in Chrysler Group LLC vehicles. High-strength materials can be substantially and negatively affected from heat input which will not be obviously known to the repairer or consumer. Additionally, application of heat will alter or destroy material coatings utilized for corrosion protection and which may not be restorable.

Ignoring these recommendations may lead to serious compromises in the ability to protect occupants in a future collision event, reduce the engineered qualities and attributes, or decrease the durability and reliability of the vehicle.

*This statement supersedes any previously released information by Chrysler Group LLC.*

Release Date: August 11, 2010



**DODGE**

**CHRYSLER**

**Jeep**

For more information, log on to [www.MoparRepairConnection.com](http://www.MoparRepairConnection.com).

# Structural Repair Position Statements - Ford

1. Ford "Clip" Repair Procedure Not Recommended – February 28, 2005



# STATEMENT

**Contact:** Steve Nantau  
734-523-1305  
snantau@ford.com

## **IMMEDIATE RELEASE**

### **“CLIP” REPAIR PROCEDURE NOT RECOMMENDED**

**NOTE TO EDITOR:** *The use of front or rear “clips” to repair major damage to a vehicle is a practice among collision repairers and insurance companies, which pay for the majority of collision repairs. The practice involves replacing an entire section of a vehicle with a similar section from a “donor” vehicle – most frequently one that has been declared a total loss. This Statement has been developed to answer frequent questions about “clipping” that Ford Motor Company receives from collision repairers.*

**DEARBORN, Mich., February 28, 2005** – Ford Motor Company does not approve the use of “clips” to repair collision damage to vehicles.

The use of a “clip” to repair collision damage voids Ford’s New Vehicle Limited Warranty and any variety of Ford’s Extended Service Plan, as well as Ford’s new vehicle service part and corrosion warranties for each part in the “clip.” Use of a “clip” also voids any variety of Ford’s Extended Service Plan, new vehicle service part warranty and corrosion warranty for any damage to individual components, assemblies or systems on the original vehicle caused by individual components, assemblies or systems in the “clip.”

Go to <http://media.ford.com> for news releases and high-resolution photographs.



Ford strongly recommends that repairers and insurers considering the use of a “clip” carefully check state collision repair laws and regulations to determine whether the vehicle must be re-titled as “rebuilt” or “salvage” if the “clip” procedure is used. Ford also strongly recommends that repairers advise and obtain the written repair authorization of the vehicle owner, in advance, if the “clip” procedure is to be used and re-titling is required.

Ford has adopted this position because it cannot be confident “clip” repair procedures return vehicles to pre-accident condition. Because every “clip” repair is unique, it is impossible to test whether the repair technique affects the safety, performance or durability of the vehicle. Other factors weigh heavily in this position, including:

- Hidden damage to individual components, assemblies or systems in the “clip” that may not be readily apparent to the repairer.
- Improper removal techniques and exposure to weather that may degrade the performance characteristics of individual components, assemblies or systems in the “clip.”
- Mismatching of individual components, assemblies or systems. Individual component, assembly and system modifications occur throughout the production life of new-model vehicles. It is possible a “clip” component, assembly or system will not be compatible with the vehicle it is being used to repair.

Ford recommends that only genuine Ford replacement parts be used for collision repair to protect all parties – vehicle owners, repairers and insurers – involved in the collision repair process.

Ford also is working diligently to control the cost of major collision repairs. After research and testing, it has developed several frame sectioning procedures – and unique frame sectioning repair parts – that have been proven not to affect the safety, performance or durability of the repaired vehicle. Ford recommends repairers and insurers consider these procedures as a practical and cost-effective alternative to “clipping.”

February 28, 2005

###

Go to <http://media.ford.com> for news releases and high-resolution photographs.

# Structural Repair Position Statements - Honda

1. Honda Unibody Repair – June 18, 2007
-



## POSITION STATEMENT

### **SUBJECT: HONDA UNIBODY REPAIR**

TORRANCE, Calif., June 18, 2007 – American Honda Motor Co, Inc. makes the following recommendations for repair of Honda and Acura vehicles.

#### **Sectioning Frame Components**

When body repairs are necessary, American Honda recommends that any repairs be performed by an experienced professional, using the Honda or Acura body repair manual, and that component replacement be accomplished along factory seams. Failure to do so can result in a number of problems, including improperly fitting parts, noises, tire wear, and most importantly, changes in vehicle dynamics and occupant protection in a subsequent crash.

In particular, American Honda strongly recommends against the process of joining cut pieces from separate vehicles - commonly referred to as clipping. This is not an authorized American Honda repair method. Any problems with other components resulting from such improper vehicle repairs is not covered under American Honda's factory or extended warranties.

#### **Adhesives and Welding**

Using adhesives in place of welding for component replacement is not an authorized American Honda repair method. It is important to repair at factory seams using the same procedures as the factory assembly process except where specified otherwise in the Honda or Acura body repair manual.

#### **Door and Bumper Reinforcements**

Because they are made of high strength steel, door and bumper reinforcements must not be repaired or straightened.

#### **Replacement Parts**

American Honda strongly recommends the use of Honda Genuine or Acura Precision Crafted original equipment replacement parts. Use of these parts helps return the vehicle to its pre-crash condition.

# # #

AJA 38307 (0710)

# Structural Repair Position Statements – Toyota / Lexus

## ***Electrical***

1. SRS & HV Wiring Repairs – August 2007 – Bulletin #156
2. SRS Precautions – December 2007 – Bulletin #160
3. SRS Occupant Classification System Initialization – March 2010 – Bulletin #177

## ***Exterior***

1. Body Sectioning – February 2003 – Bulletin #122
2. Wheel Repair and Reconditioning – June 2007 – Bulletin #154
3. Body and Frame Sectioning – August 2007 – Bulletin #155
4. Collision Parts Position Statement – August 2007 – Bulletin # 157
5. Corrosion Prevention & Sound Absorbing Measures – December 2007 – Bulletin #159
6. Quarter Panel Service Part Modification – February 2008 – Bulletin #162
7. Sealing Hem-Flanges and Body Seams – February 2008 – Bulletin #163
8. Bumper Component Repair – March 2009 – Bulletin #172
9. Use of Non-OEM Parts on Toyota Vehicles – December 2010 - Bulletin #180

## ***Refinish***

1. Paintless Dent Repair – August 1994 – Bulletin #60
2. Refinish Procedures for Panels without Body Lines – December 1994 – Bulletin #65
3. Topcoat Sand & Polish – April 2009 – Bulletin #173

## ***Structural***

1. Collision Damage Repair Precautions – January 2007 – Bulletin #161
2. HSS &UHSS Cabin Reinforcement Repair & Replacement – December 2009 – Bulletin #175

## ***Welding***

1. Welding High Strength Steel (H.S.S.) – July 1988 – Bulletin #27
2. Welding Ultra High Strength Steel – August 2009 – Bulletin #174

# COLLISION REPAIR INFORMATION

## FOR THE TOYOTA DEALER

TITLE: WELDING HIGH STRENGTH  
STEEL (H.S.S.)

PAGE 1 of 5

SECTION: WELDING BULLETIN #27

MODELS: ALL TOYOTA MODELS

DATE: JULY 1988



In today's body shop environment high strength steel (H.S.S.) body parts are frequently welded during collision damage repairs. Typical uses for H.S.S. are the front cross member, front body outer pillar, floor side member and door side impact protection beam. Because H.S.S. is used in these areas of potential high stress, repairs must be done properly to maintain the structural integrity of the vehicle.

Two types of H.S.S. are used. Solution hardened H.S.S. is used for door panels, hood outer panel, etc., while precipitation hardened H.S.S. is used for door impact beams and bumper reinforcements. It is not necessary to distinguish solid solution hardened steel from ordinary steels for repair purposes.

The location of H.S.S. parts can be found in the Toyota Repair Manual for Collision Damage under the Body Panel Construction section. A sample chart from the 1987 Camry Collision Repair Manual is on page 3 of this bulletin. A list of available Toyota Collision Repair manuals is on page 4.

### REPAIR GUIDELINES

H.S.S. and ordinary steel parts in Toyota vehicles are welded using the same methods. The following precautions apply:

- Use either spot welding or MIG/MAG (shield gas) welding. MIG/MAG (shield gas) welding should only be done by an experienced body shop person.
- Only braze body components previously brazed at the factory and as indicated in the Toyota Repair Manual for Collision Damage.
- Do not use an oxy-acetylene torch for fusion welding auto bodies. The large heat affected zone may destroy galvanized coatings and cause excessive panel distortions. In addition, an oxy-acetylene torch will reduce the strength and increase the brittleness of H.S.S.



**REFERENCE MATERIALS**

The following manuals should be readily available in the body shop:

- Toyota Fundamental Body Repair Procedures Manual
- Complete set of Toyota Repair Manuals for Collision Damage

**TOOLS**

Proper tools are mandatory for H.S.S. repair. Tools include:

- MIG/MAG welder
- Spot welder
- H.S.S. spot weld cutter that will cut 8mm and 10mm holes
- Air saw
- Plasma cutter
- Air power chisel with panel cutter
- Hole punch
- Head protector
- Dust mask
- Face protector
- Vise grip pliers
- Weld through primer (see page 5 of this bulletin)
- Ear plugs
- Car cover for glass and interior

**WELDS**

Four types of welding are required in the repair of Toyota vehicles:

- Spot
- Plug
- Continuous
- Braze

Technicians doing repair work must be proficient in doing all four types of welding since all four are used in various locations throughout the vehicle. The Toyota Repair Manuals for Collision Damage show the location and type of welds that must be used. The correct number and type of welds must be used to ensure structural integrity.

**PROCEDURE**

The complete in-depth procedure for welding H.S.S. and ordinary steel can be found in the Toyota Fundamental Body Repair Procedures manual for the applicable vehicle. The basic procedure requires:

1. Removal of auxiliary parts
2. Removal of damaged parts
3. Prepare new parts
4. Position new parts
5. Welding
6. Finishing of welded areas.

**BODY PANEL CONSTRUCTION — High Strength Steel (H.S.S.) Parts**

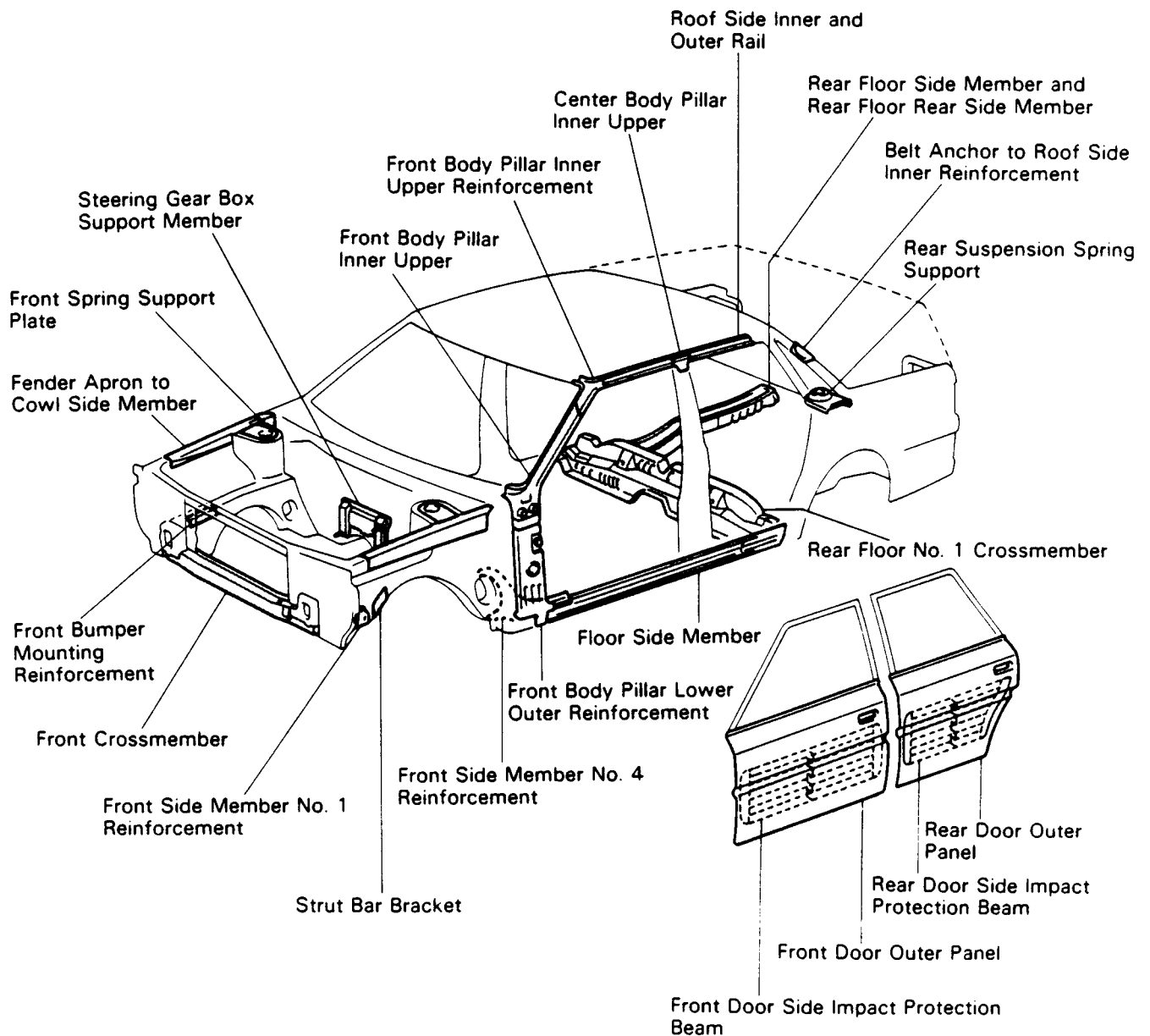

## TOYOTA SERVICE PUBLICATIONS

PART NUMBER	DESCRIPTION
3643-8E	Fundamental Painting Procedures
BRM00-2E	Fundamental Collision Repair
3643-1E	Tercel 2WD
3643-2E	Tercel 4WD
3643-4E	Corolla 83-87
36182	Celica/Supra 82-86
BRM00-1E	Celica 86-88
BRM00-5E	Supra 86-88
3643-3E	Camry 83-86
36118	Cressida 81-84
3644-1E	Cressida 85-88
3644-2E	Cressida Wgn. 85-88
3644-oA	MR2 85-88
BRM00-3E	Van 84-87
BRM01-1U	Tercel Coupe 87-88
BRM01-0U	Camry 87
BRM00-7U	Tercel Sedan 87-88
BR012	Corolla 88
BRM00-6E	FX/FX 16 87-88
BRM00-9E	Supra Sport Roof 86-88
BRM00-8E	MR2 T-Roof 85-88

You may order these on your TDN through the non-parts ordering system.



**WELD-THROUGH PRIMER SUPPLIERS \***

1. HTP "Cold Galvanizing Compound"  
Part No. 12022  
HTP America, Inc.  
261 Woodwork Lane  
Palatine, IL 60067
2. TTE "Dan-Prime"  
Transnational Technology Enterprises, Inc.  
3541 Old Conejo Road, #107  
Newbury Park, CA 91320
3. Anchor Brand "Spray-Galv"  
NASCO  
Welding Equipment and Safety Supplies  
Chicago, IL
4. 3M "Weld-Thru Coating"  
Part No. 051131-05913  
3M Automotive Trades Division  
St. Paul, MN
5. Kent "Spotweld Primer"  
Part No. 50190  
Kent Industries  
4500 Euclid Ave.  
Cleveland, OH 44103

\* There may be other sources for this material that are not listed here.

# COLLISION REPAIR INFORMATION

## FOR THE TOYOTA DEALER

TITLE: PAINTLESS DENT REPAIR

PAGE 1 of 1

SECTION: REFINISH BULLETIN #60

MODELS: ALL

DATE: AUGUST 1994

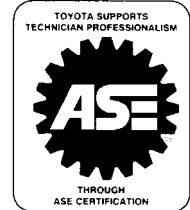

Toyota's Technical and Body Training Development has completed its evaluation of "paintless dent repair" procedures marketed to the collision repair industry. In general, the damage is "door ding" type where an obvious point of impact exists.

Toyota does not approve of this repair procedure based upon the following analysis:

1. The vehicle is not returned to a "pre-accident" condition in these areas:
  - The paint film no longer has its original strength due to microcracking, the immediate appearance may look acceptable, over time however, ultimately refinishing may be required. Microcracking of the paint film can range from fine cracking visible only by magnification to the very obvious (easily seen with the naked eye), depending upon the initial damaging impact.
  - Potential exposure of the metal substrate to condensation accelerates rust penetration. The base coat may also be degraded by ultraviolet (UV) light penetration through the clear coat.
2. Mechanical manipulation disrupts the factory applied rust and corrosion protective coating, and in some cases removes it completely from the back of the panel. Repair technicians experience difficulty replacing this important component of longevity, potentially reducing the long-term value of the vehicle.
- 3 In some cases, gaining access to the backside of a door panel is accomplished by unacceptable procedures:
  - Using blocks as a wedge between the window molding and the glass for tool access damages the window rubber/molding and relieves the factory designed pressure on the window glass.
  - Drilling holes in the end of a panel allows corrosion to begin at the site or a path to the back of the panel.

In the interest of customer satisfaction and safety, Toyota does not approve of these methods. As new tools and technologies come to market, Toyota will evaluate the processes for appropriate application.



# COLLISION REPAIR INFORMATION

## FOR THE TOYOTA DEALER

TITLE: REFINISH PROCEDURES FOR PANELS  
WITHOUT BODY LINES

PAGE 1 of 2

SECTION: REFINISH BULLETIN #65

MODELS: ALL

DATE: DECEMBER 1994

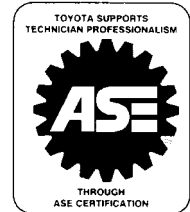

Late model Toyota vehicles offer eye-pleasing customer appeal associated with leading edge technology. As body styles continue to get smoother and more aerodynamic, refinish technicians face difficult decisions in meeting customer expectations when refinishing smooth panels without body lines.

Historically, refinish technicians used a technique called “solvent blending” on areas without character or body lines. This system worked well on old technology thermoplastic/thermoset finishes. However, vehicles today utilize more sophisticated paints applied at the factory that do not lend themselves to this type of repair procedure. The reason is simple; the bond between the OEM finish and the newly applied refinish paint cannot “blend” or “melt” into one another.

Problems directly attributed to solvent blending are:

- **peeling** (caused by poor adhesion between the OEM and refinish coat)
- **visible paint lines** (caused by polishing, buffing or detailing the thin resin area)
- **complying with legislation** (volatile organic compound (VOC) regulations prohibit solvent blending in many areas).

To meet this challenge, and maintain environmental compliance, Toyota recommends the following procedure for restoring your customer’s vehicle to pre-accident condition:

- Remove moldings from the panel as well as any adjacent panel.
- Mask the vehicle as usual to prevent overspray.
- Chemically clean the vehicle prior to any spray application.
- Apply base color coat to the spot repair site.
- Spray into the adjacent panel as necessary for an undetectable color match.
- Apply the first coat of urethane clear coat to the repair site only.
- For a two clear coat system, spray only the second coat to the end of the panel.
- For a three clear coat system, spray only the final coat to the end of the panel.



## WITHOUT BODY LINES (cont'd)

The process is fundamentally the same for refinishing any panel, but the professional difference is where the application of the clear coat ends. Spraying the final full coat insures maximum adhesion, ultra-violet sunlight protection and is environmentally safer. Over-reduced clear coats, used during a solvent blend, **can not** provide the same level of high quality repairs.

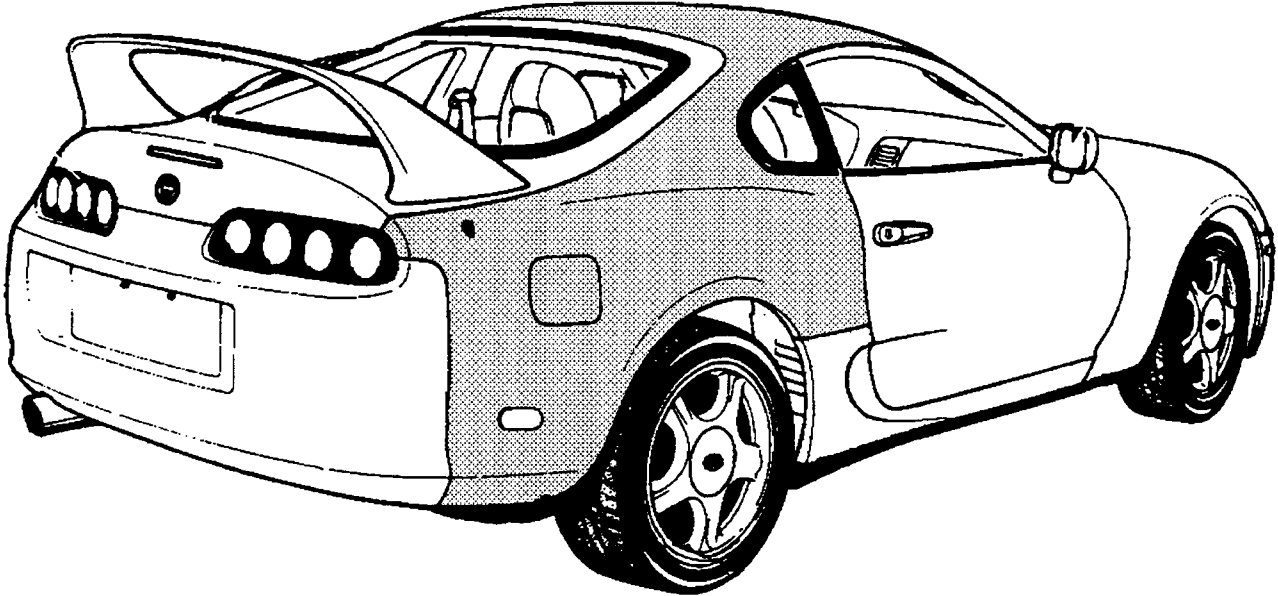

As the illustration above shows clearly, no body lines exist, so applying the last coat of clear to the nearest panel edge is necessary. However, if a character or body line does exist, using a method known as reverse taping is recommended. This procedure is well known in the automotive refinishing industry.

Toyota provides two additional informational resources:

- Advanced Painting Techniques—a self-study video-based training package (part number 00415-10004) containing a 20 minute video, technician reference guide, job aid and a wall poster.
- Fundamental Painting Procedures—particularly pages 3-49. This is an excellent overall guide to painting.

# COLLISION REPAIR INFORMATION

## FOR THE TOYOTA DEALER

TITLE: BODY SECTIONING

PAGE 1

SECTION: EXTERIOR BULLETIN #122

MODELS: ALL TOYOTA/LEXUS

DATE: FEB 2003

Toyota actively promotes quality repairs by providing Collision Repair Centers with updates and changes in collision repair procedures, standards and technology.

Full body sectioning, also known as “clipping” is **NOT** an approved repair procedure on any Toyota or Lexus vehicle.

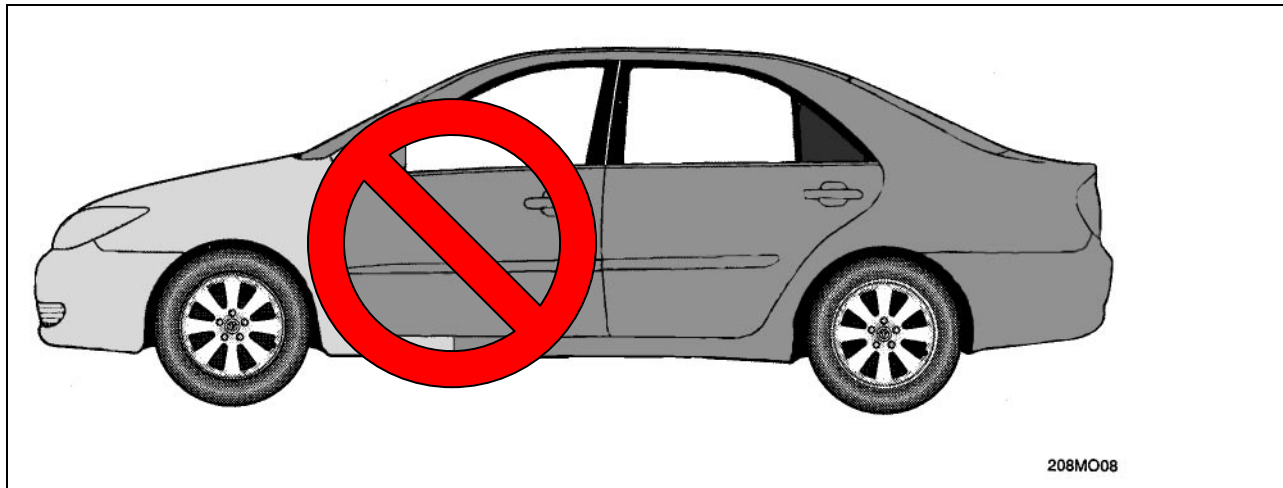

Full body sectioning is generally done on a vehicle that has sustained severe rear end damage, where the front portion of one vehicle is joined to the rear portion of another vehicle.

Full body sectioning is **not approved** for the following reasons:

- Decrease in strength and safety from the original Toyota/Lexus design
- Poor fit and alignment of the body
- NVH (squeaks, rattles, etc.)
- Wind noises and water leaks
- Diminished protection from rust/corrosion

Always refer to the Toyota/Lexus model-specific repair manual for approved cut/join locations, measurements, welding requirements, and other important information.

**PLEASE ROUTE THIS BULLETIN TO YOUR COLLISION REPAIR CENTER MANAGER  
AND COLLISION REPAIR TECHNICIANS**

# COLLISION REPAIR INFORMATION

## FOR THE TOYOTA DEALER

TITLE: FULL FRAME COMPONENTS PAGE 1 OF 2  
SECTION: STRUCTURAL BULLETIN # 136  
MODELS: ALL TOYOTA/LEXUS PERIMETER FRAME VEHICLES  
DATE: SEPTEMBER 2003

---

### Background

During a collision, components attached to the perimeter frame may be damaged and can be replaced individually when service parts are available. Serviceable parts include:

- **body mounts**
- **cross members**
- **mounting flanges**
- **suspension mounts**

Example: 2003 Lexus LX 470

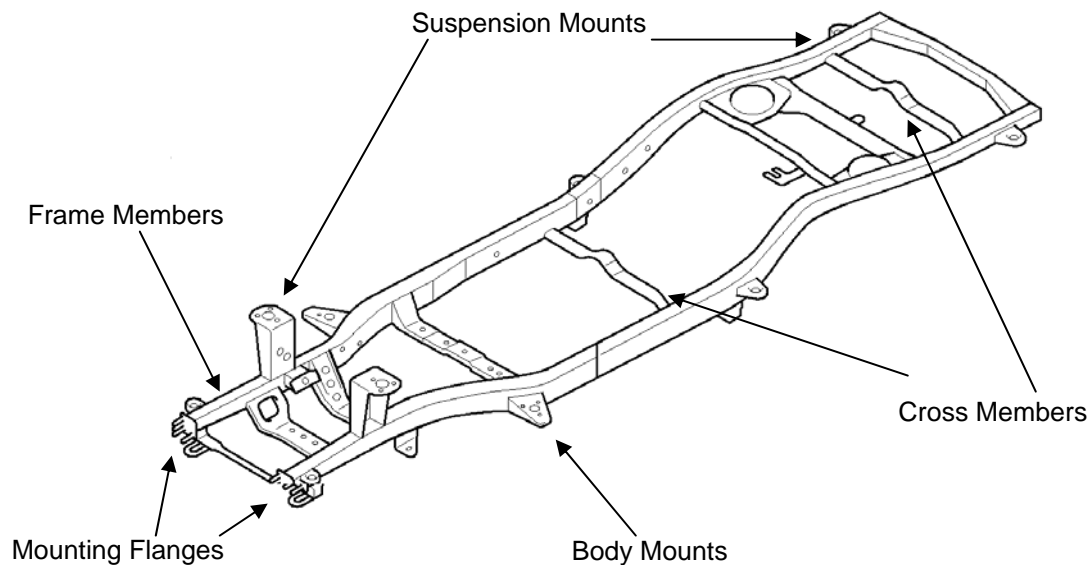

**Note:** Sectioning of structural members on perimeter framed vehicles **is not** an approved repair procedure. Sectioning is defined as the partial replacement of welded on structural members or panels at a location other than the factory seam or joint.

**PLEASE ROUTE THIS BULLETIN TO YOUR COLLISION REPAIR CENTER MANAGER  
AND COLLISION REPAIR TECHNICIANS**

## Specified Models

Listed below are the current Toyota and Lexus models that feature a body over perimeter frame design:

### Toyota

- 4Runner
- Land Cruiser
- Sequoia
- Tacoma
- Tundra

### Lexus

- GX 470
- LX 470

## Frame Repair Precautions

**Since all Toyota and Lexus frames are made of High Strength Steel (HSS); Toyota does not approve of the use of open flame heating or any heating device to stress relieve HSS during the repair process.** Heating HSS may alter the strength, durability, and quality of the steel.

“Cold straightening” (stress relieving) is the only repair method presently approved to repair perimeter frames. If the perimeter frame cannot be satisfactorily restored to original dimensions during this process, it should be replaced.

Do not overheat the steel when attaching welded components to the frame, as overheating can adversely affect the strength characteristics of the steel.

If crush rivets and installation equipment are not available, factory riveted components may be attached using SAE Grade 8 heat-treated shouldered bolts with a minimum tensile strength rating of 150,000 psi, washers, and self-locking nuts. Recommended torque is 73-97 Lb-Ft. Refer to I-CAR Universal Procedure for Collision Repair (UPCR) SP11S, 9.5 Riveted-On Part Replacement for more information on this topic.

Toyota/Lexus only support the use of genuine OEM replacement parts for collision repair.

For additional information, plan to attend a Toyota or Lexus collision repair training course. For training course schedule and registration, contact your Dealership Service Manager.

# COLLISION REPAIR INFORMATION

## FOR THE TOYOTA DEALER

TITLE: WHEEL REPAIR & RECONDITIONING

SECTION: EXTERIOR BULLETIN # 154

MODELS: ALL TOYOTA, LEXUS, and SCION MODELS

DATE: JUNE 2007

---

Toyota does not approve of “reconditioning wheels” or endorse the use of reconditioned wheels on any Toyota, Lexus, or Scion vehicle. **Use of any wheel or tire not recommended by Toyota may compromise safe motor vehicle operation, and cause loss of control which may result in injury or death.**

Reconditioning of damaged wheels typically involves processes that may include heating, straightening, welding, material removal, reshaping, or re-plating. It is nearly impossible to anticipate every conceivable damage scenario or countermeasure, or to certify that reconditioned wheels meet original equipment specifications.

All wheels suspect of damage should be thoroughly inspected and evaluated with the highest regard for safety. Use only Toyota recommended replacement wheels and tires. **Approved wheel repairs are limited to cosmetic sanding and refinishing processes that remove and replace only paint coatings.**



**PLEASE ROUTE THIS BULLETIN TO YOUR COLLISION REPAIR CENTER  
MANAGER AND COLLISION REPAIR TECHNICIANS**

00408-03000-154



# COLLISION REPAIR INFORMATION

## FOR THE TOYOTA DEALER

TITLE: BODY & FRAME SECTIONING

SECTION: EXTERIOR BULLETIN # 155

MODELS: ALL TOYOTA, LEXUS, and SCION MODELS

DATE: AUGUST 2007

---

**Approved panel replacement procedures, including non-structural and structural sectioning specifications for unibody vehicles are model-, and component-specific. Frame component sectioning is not an approved procedure. Cut and join locations, welding specifications, illustrations, and instructions can be found in model-specific Repair Manuals for Collision Damage. Specifications provided are for new undamaged original equipment service parts. Visit [www.techinfo.toyota.com](http://www.techinfo.toyota.com) to access repair manuals and technical information.**

**Body Sectioning with salvage parts is not an approved repair method.** This position is stated clearly in CRIB #122 Full Body Sectioning, released February 2003.

**Frame Sectioning is considered partial replacement of a frame rail or component, and is not an approved repair procedure on full frame Toyota and Lexus vehicles.** This position is stated clearly in CRIB #136 Full Frame Components, released September 2003. CRIB #136 provides information to enhance a collision repair professional's ability to make better decisions about frame repairs, and should not be interpreted to include every frame component replacement scenario. For more detailed information on this topic plan to attend Toyota/Lexus Collision Repair & Refinish, Non-Structural and Structural Body Repair Training. Visit [www.crrtraining.com](http://www.crrtraining.com) for training registration information.

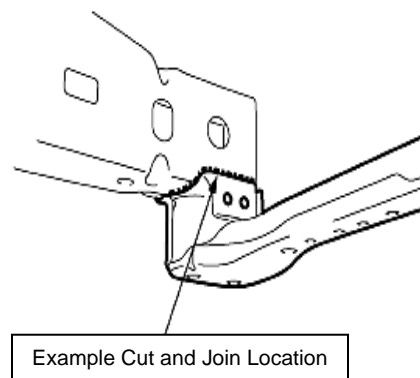
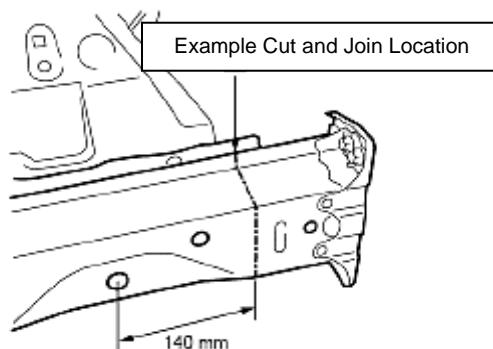

**PLEASE ROUTE THIS BULLETIN TO YOUR COLLISION REPAIR CENTER  
MANAGER AND COLLISION REPAIR TECHNICIANS**

00408-03000-155

# COLLISION REPAIR INFORMATION

## FOR THE TOYOTA DEALER

TITLE: SRS & HV WIRING REPAIRS

SECTION: ELECTRICAL BULLETIN # 156

MODELS: ALL TOYOTA, LEXUS, and SCION MODELS

DATE: AUGUST 2007

---

**There are no approved repairs to Supplemental Restraint System (SRS) or High Voltage (HV) wiring or connectors.** SRS system wiring and connectors are color coded yellow, and HV wiring is orange, however, vehicle-specific wiring diagrams are the best source for identifying wiring in these circuits. Wiring diagrams are available through the Technical Information System (TIS) at [www.techinfo.toyota.com](http://www.techinfo.toyota.com).

If SRS or HV wiring or connectors are suspected of damage they should be inspected thoroughly. Damaged wiring and/or connectors require replacement of the affected harness. Follow all precautions and procedures outlined in model-specific repair manuals for replacing SRS wiring or components. **Only Certified Hybrid Service Technicians are qualified to replace HV system wiring and components.**



**Example SRS Wiring  
(yellow)**



**Example HV Wiring  
(orange)**

**PLEASE ROUTE THIS BULLETIN TO YOUR COLLISION REPAIR CENTER  
MANAGER AND COLLISION REPAIR TECHNICIANS**

00408-03000-156

# **COLLISION REPAIR INFORMATION**

## **FOR THE COLLISION REPAIR PROFESSIONAL**

TITLE: COLLISION PARTS POSITION STATEMENT

SECTION: EXTERIOR BULLETIN # 157

MODELS: ALL TOYOTA, LEXUS, and SCION

DATE: AUGUST 2007

---

### **WARRANTIES**

Toyota vehicle factory warranties transfer when repairs are completed with new Toyota Genuine Parts. The use of used salvage and or imitation counterfeit parts is not covered by the Toyota transferable limited warranty on such parts and all adjoining parts and systems which are caused to fail or rust by those parts. Refer to CPS-Toyota/Scion Policy 4.17 and CPS Lexus Policy 4.15 for details on what is not covered by the new vehicle limited warranty.

### **USED SALVAGE PARTS**

Toyota Motor Sales, U.S.A, Inc. is an environmentally conscious corporate citizen. We understand the merits of recycling and promote them. Additionally, we are concerned about our customers and maintaining Toyota vehicle image, value, functional and safety systems, and transferable factory warranties. Since Toyota does not warrant used salvage parts, we want to make sure customers are aware of the consequences of having used salvage parts installed on their vehicles. At this time, we believe there are no systems or processes in place to regulate the quality of used salvage parts in the market. Therefore, we are concerned about improper use of used salvage parts, i.e., wrong application as well as the use of damaged materials.

### **SUPPLEMENTAL RESTRAINT SYSTEMS (SRS)**

Due to the critical nature of the Supplemental Restraint Systems, also known as air bags, Toyota does not support the use of any used salvage or imitation parts for repair. Only new Toyota Genuine Parts should be used in repairs.

REPRINT OF TOYOTA GENUINE PARTS POSITION STATEMENT #MDC00117-00900

**PLEASE ROUTE THIS BULLETIN TO YOUR COLLISION REPAIR CENTER  
MANAGER AND COLLISION REPAIR TECHNICIANS**

00408-03000-157

## REPLACEMENT CRASH PARTS DISCLOSURE AND AUTHORIZATION FORM

NOTICE TO TOYOTA, LEXUS, AND SCION OWNERS:

1. "Replacement Crash Parts" are the parts typically replaced during the repair of a damaged vehicle. These parts include, but are not limited to, exterior sheet metal and plastic components (such as fenders, hoods, doors, bumper systems and related structural components).
2. The types of replacement crash parts listed in your estimate/repair order # \_\_\_\_\_ (copy attached) are identified as one or more of the categories listed below in section 4.
3. Warranties for the replacement crash parts listed below are provided by the manufacturer or distributor. Warranty coverage varies. Ask your insurer or collision repair professional for specific written warranty information. Additional warranties for replacement crash parts will be provided by \_\_\_\_\_.
4. Replacement Crash Part Types:

NEW OEM (Original Equipment Manufacturer)

Parts which are made by the vehicle manufacturer or one of its licensees and distributed through its normal channels. These parts maintain the OEM Vehicle Factory Warranty for the replacement part and any other adjoining or associated OEM parts or systems.

AFTERMARKET

Parts which are made by companies other than the vehicle manufacturer or its licensees. All parts in this category are warranted by the distributor and/or manufacturer of these parts.

RECYCLED/RECYCLABLE

Used parts and assemblies which have been removed from another vehicle. All parts in this category are warranted by the salvage distributor.

REMANUFACTURED

Parts which have been returned to like-new condition by repairing, re-machining, or rebuilding. All parts in this category are warranted by the manufacturer of the part.

I understand that my vehicle will be repaired using the parts described above and I authorize the repair facility to install those parts.

---

Customer Signature

Date

**PLEASE ROUTE THIS BULLETIN TO YOUR COLLISION REPAIR CENTER  
MANAGER AND COLLISION REPAIR TECHNICIANS**

# COLLISION REPAIR INFORMATION

## FOR THE COLLISION REPAIR PROFESSIONAL

TITLE: CORROSION PREVENTION & SOUND ABSORBING MEASURES  
SECTION: EXTERIOR BULLETIN #159  
MODELS: ALL TOYOTA, LEXUS, and SCION  
DATE: DECEMBER 2007

---

**To assure repairs and replacement components meet strict factory standards, all corrosion preventive coatings and sound absorbing materials must be replicated to match OE application and purpose. In addition, the use of weld thru primer is strongly recommended during welding operations.**

If the following materials are not restored to OE like-kind and quality, road noise may be amplified, and the Toyota new car corrosion warranty may be voided on the affected components, and adjoining parts and systems which are caused to fail or rust by those components. Refer to CPS-Toyota/Scion Policy 4.17 and CPS Lexus Policy 4.15 for details on what is not covered by the new vehicle limited warranty.

- Seam Sealer
- Undercoating
- Cavity Wax
- Frame Finish Coatings
- Sound Absorbing Materials
- ED Primer
- Chip Resistant Coatings

Please refer to model-specific Collision Damage Repair Manuals ([www.techinfo.toyota.com](http://www.techinfo.toyota.com)) for specifications, illustrations, instructions, and locations of these coatings.



(PRODUCTS ARE FOR ILLUSTRATION PURPOSE ONLY)

**PLEASE ROUTE THIS BULLETIN TO YOUR COLLISION REPAIR CENTER  
MANAGER AND COLLISION REPAIR TECHNICIANS**



00408-03000-159

# **COLLISION REPAIR INFORMATION**

## **FOR THE COLLISION REPAIR PROFESSIONAL**

TITLE: SRS PRECAUTIONS  
SECTION: ELECTRICAL BULLETIN #160  
MODELS: ALL TOYOTA, LEXUS, and SCION  
DATE: DECEMBER 2007

---

For vehicles equipped with Supplemental Restraint System (SRS) Airbags and Seat Belt Pretensioners, failure to follow diagnostics and servicing procedures in the correct sequence could cause the SRS to deploy unexpectedly and lead to serious injury. Furthermore, if a mistake is made while servicing the SRS, it is possible the SRS may fail to operate properly. Be sure to read and follow all applicable precautions and service information closely. SRS service information can be found in model-specific Repair Manuals ([www.techinfo.toyota.com](http://www.techinfo.toyota.com)).

### **Important SRS Precautions include, but are not limited to:**

- **When troubleshooting the SRS, always check for Diagnostic Trouble Codes (DTC's) before disconnecting the battery.**
- **If one or more DTC's are displayed, note each DTC, then disconnect; the negative (-) battery terminal, the malfunctioning circuit, and the SRS computer connector.**
- **Work must be started no less than 90 seconds after the SRS power source has been disconnected to allow for back-up power discharge.**
- **In minor collisions where the SRS does not deploy, all SRS components and wiring should be inspected before further use of the vehicle.**
- **Never use SRS components or wiring from another vehicle, use only new Genuine OE parts.**
- **Before body repairs, remove airbag sensor assemblies if shocks are likely to be applied near the sensors.**
- **Never attempt to disassemble or repair airbags, pretensioners, or sensor assemblies.**
- **Do not attempt to refinish any SRS components, covers, or trim. Refinish materials may alter deployment characteristics.**
- **Do not expose any SRS components or wiring to excessive heat or open flame.**
- **Do not probe SRS wiring with a test light. Use a voltmeter/ohmmeter with high impedance (minimum 10 k $\Omega$ ) for troubleshooting.**
- **When using electric welding anywhere on the vehicle, disconnect the 12 volt battery and the center airbag sensor assembly connectors. These connectors contain shorting pins. This feature reduces the possibility of airbag deployment due to current entering the squib wiring.**
- **Never connect or disconnect the center airbag connectors without the sensor being secured in its factory installed location.**
- **Never reuse a center airbag sensor that has been involved in a collision where the SRS has deployed.**
- **Never repair SRS wiring or connectors. Replace damaged wiring.**

**PLEASE ROUTE THIS BULLETIN TO YOUR COLLISION REPAIR CENTER  
MANAGER AND COLLISION REPAIR TECHNICIANS**



00408-03000-160

# COLLISION REPAIR INFORMATION

## FOR THE COLLISION REPAIR PROFESSIONAL

TITLE: COLLISION DAMAGE REPAIR PRECAUTIONS

SECTION: STRUCTURAL BULLETIN # 161

MODELS: ALL TOYOTA, LEXUS, and SCION

DATE: JANUARY 2008

PAGE 1 OF 2

The following collection of precautions is intended to reinforce Toyota's position on some key collision repair topics, and should not be considered all inclusive or a substitute for training. For more information on these and other important collision repair and refinish topics plan to attend Collision Repair & Refinish Training. Visit the CR&R website ([www.crrtraining.com](http://www.crrtraining.com)) for schedule and registration information.

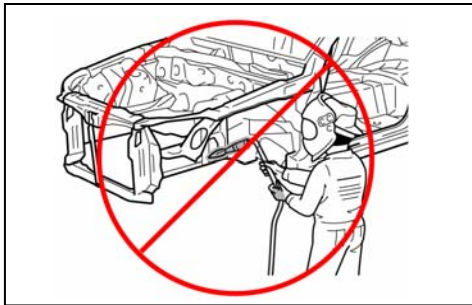

### **HEAT REPAIR FOR BODY AND FRAME COMPONENTS IS PROHIBITED**

High strength sheet steel is used for structural body, and frame components. If these components are repaired with heat the crystalline structure changes, causing a significant decrease in strength. Heat also damages the zinc coating reducing corrosion resistant properties.

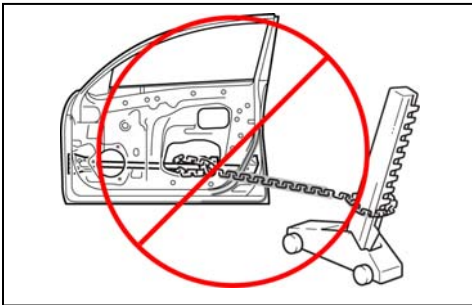

### **INTRUSION BEAM REPAIR IS PROHIBITED**

Intrusion beams are designed to absorb, channel, and dissipate collision energy and perform at 100% strength in their original shape. However, if they are damaged and repaired they will no longer perform as intended. Damaged intrusion beams require complete door replacement.

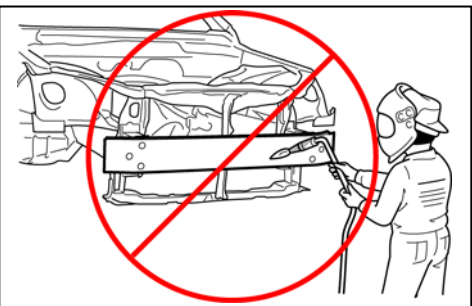

### **BUMPER REINFORCEMENT REPAIR IS PROHIBITED**

Bumper reinforcements are designed to absorb, channel, and dissipate collision energy and perform at 100% strength in their original shape. However if they are damaged and repaired, they will no longer perform as intended. Damaged bumper reinforcements require replacement.

**PLEASE ROUTE THIS BULLETIN TO YOUR COLLISION REPAIR CENTER  
MANAGER AND COLLISION REPAIR TECHNICIANS**



00408-03000-161

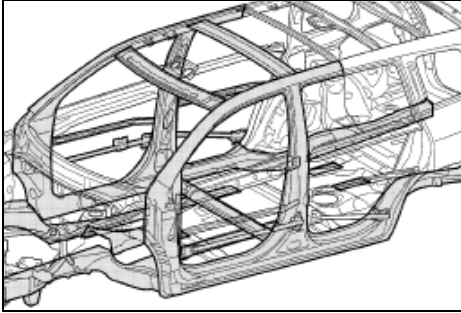

**HIGH STRENGTH & ULTRA HIGH STRENGTH STEEL (HSS & UHSS) OCCUPANT CABIN REINFORCEMENT REPAIR IS PROHIBITED**

HSS & UHSS occupant cabin reinforcements are designed to absorb, channel, and dissipate collision energy and perform at 100% strength in their original shape. However if they are damaged and repaired, they will no longer perform as intended. Damaged HSS cabin reinforcements require replacement.

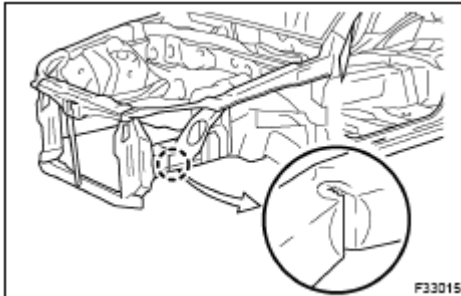

**WHEN TO REPLACE DAMAGED BODY AND FRAME COMPONENTS**

Body and frame deformations that cannot be returned to original shape by pushing, pulling, or hammering (known as cold straightening) are classified as 'kinks'. Kinks require component replacement. Deformations that can be returned to original shape by cold straightening methods are classified as 'bends'.

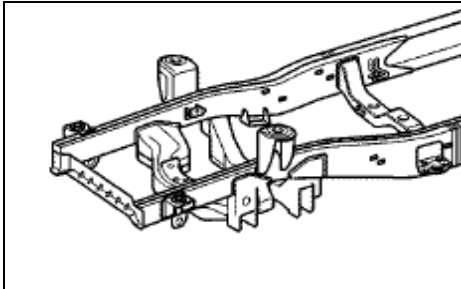

**FRAME COMPONENT REPLACEMENT IS LIMITED TO NEW GENUINE OE SERVICE PARTS ONLY**

Welded components may be installed using Gas Metal Arc Welding/Metal Inert Gas (MIG) techniques. Use ER70S3 welding wire. Ensure proper weld settings and penetration with practice welds. Do not weld over factory weld beads. Be sure to clean effected repair surfaces and apply epoxy primer and matching topcoat.

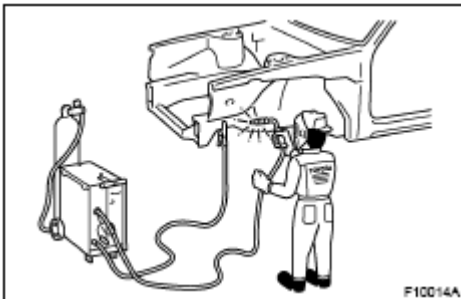

**BUTT JOINT WITHOUT BACKING IS THE APPROVED CUT AND JOIN WELDING METHOD**

Sleeves and inserts will have a negative effect on crash energy management designs. Therefore, butt joint without backing is the only approved welding method unless otherwise specified. Ensure proper root-gap, weld settings, and penetration with practice welds. Adhere to specified cut and join locations.

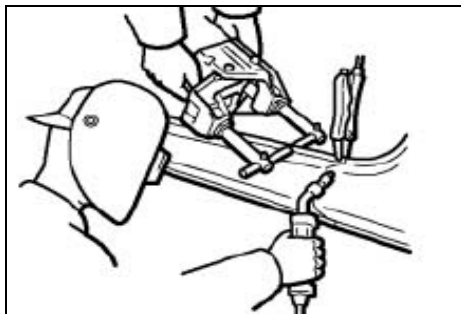

**ALWAYS OBSERVE THE FOLLOWING ELECTRIC WELDING PRECAUTIONS**

Before performing any electric welding, turn off the ignition, disconnect the negative terminal of the 12V battery, remove any ECU's within 18 inches of weld sites, and disconnect the main SRS computer connector, waiting 90 seconds before start of welding.

**PLEASE ROUTE THIS BULLETIN TO YOUR COLLISION REPAIR CENTER MANAGER AND COLLISION REPAIR TECHNICIANS**



00408-03000-161



# COLLISION REPAIR INFORMATION

## FOR THE COLLISION REPAIR PROFESSIONAL

TITLE: QUARTER PANEL SERVICE PART MODIFICATION

SECTION: EXTERIOR BULLETIN #162

MODELS: TOYOTA & LEXUS AS LISTED

DATE: FEBRUARY 2008

To improve storage and distribution logistics and reduce waste material, a change to Quarter Panel service part cuts have been made on select models. Implementation timing will vary due to number of in-stock units. Superseding part numbers will be issued as new stock arrives. The revised panel cuts are 50 mm in the roof direction from the specified cut-and-join location listed in Collision Damage Repair Manuals available from the Technical Information System (TIS) at ([www.techinfo.toyota.com](http://www.techinfo.toyota.com)). This revision does not represent any change to replacement specifications. Please refer to the illustrations and model-specific references below.

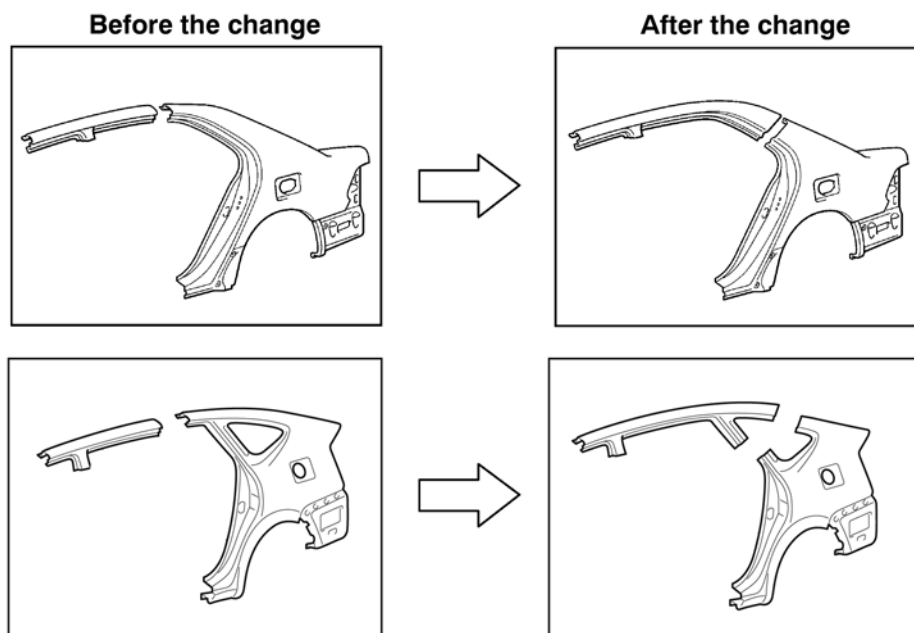

Model Name	Model Code	Production Date
LS430	UCF30	08/2000-
LS400	UCF20	10/1994-08/2000
GS300	JZS147	01/1993-08/1997
GS430/300	UZS16, JZS160	08/1997-
ES300	MCV3	07/2001-
IS300/250	GXE10, JCE10	05/2000-
Prius	NHW20	08/2003-

PLEASE ROUTE THIS BULLETIN TO YOUR COLLISION REPAIR CENTER MANAGER AND COLLISION REPAIR TECHNICIANS



00408-03000-162

# **COLLISION REPAIR INFORMATION**

## **FOR THE COLLISION REPAIR PROFESSIONAL**

TITLE: SEALING HEM-FLANGES & BODY SEAMS

SECTION: EXTERIOR BULLETIN #163

MODELS: ALL TOYOTA, LEXUS and SCION

DATE: FEBRUARY 2008

To assure factory corrosion prevention measures are replicated during body repairs, always use a like-kind and quality automotive grade sealer on hem-flanges and body seams. During manufacturing specialized materials are used however, aftermarket materials are readily available to match factory quality, application, and purpose. OE replacement body components are not supplied with seam sealer.

If replacement body components are not seam sealed, or if poor quality materials are used; the Toyota new car corrosion warranty may be voided on the affected components and adjoining parts and systems which are caused to fail or rust by those components. Refer to CPS-Toyota/Scion Policy 4.17 and CPS Lexus Policy 4.15 for details on what is not covered by the new vehicle limited warranty.

Refer to model-specific Collision Damage Repair Manuals for Body Panel Sealing Area specifications, available from the Technical Information System (TIS) at ([www.techinfo.toyota.com](http://www.techinfo.toyota.com)). The following door sealing illustration is supplied as an example.

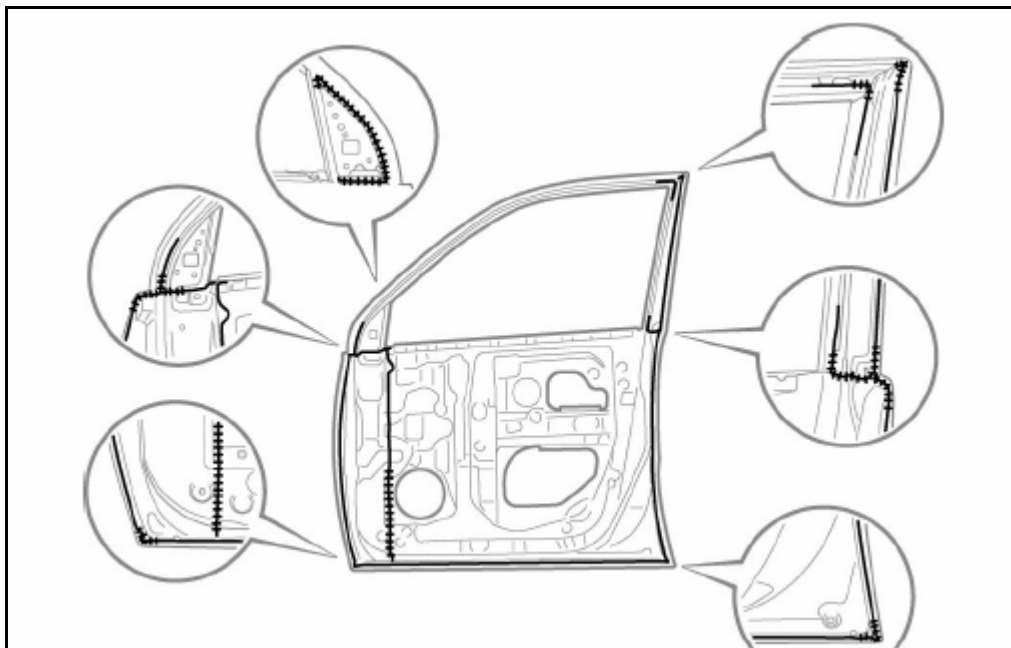

**PLEASE ROUTE THIS BULLETIN TO YOUR COLLISION REPAIR CENTER  
MANAGER AND COLLISION REPAIR TECHNICIANS**



# COLLISION REPAIR INFORMATION

## FOR THE COLLISION REPAIR PROFESSIONAL

TITLE: BUMPER COMPONENT REPAIR  
SECTION: EXTERIOR BULLETIN # 172  
MODELS: ALL TOYOTA, LEXUS, and SCION  
DATE: MARCH 2009

---

While it may seem cost effective to repair damaged bumper components, specifically impact energy absorbers and reinforcements, there is no way to certify that a repaired part will function as originally intended under all future operating conditions and subsequent collisions. Original Equipment bumper components comply with Federal Motor Vehicle Safety Standards established under the National Highway Traffic Safety Administration Title 49, Part 581. Therefore it is recommended to replace damaged bumper impact energy absorbers and reinforcements with genuine new original equipment replacement parts only.

For more information on collision damage repair topics please refer to Collision Repair Information Bulletin #161 Collision Damage Repair Precautions, and, plan to attend Toyota Collision Repair & Refinish Training. Visit [www.crrtraining.com](http://www.crrtraining.com) for training information.

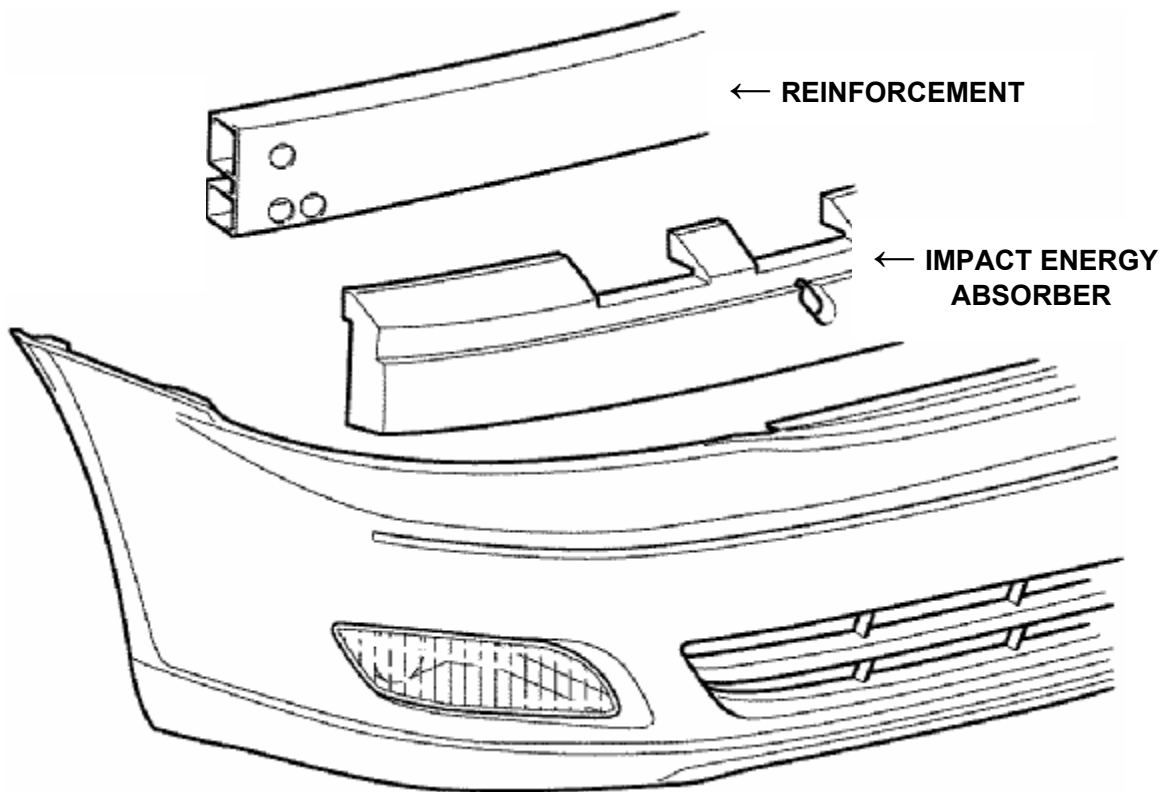

**PLEASE ROUTE THIS BULLETIN TO YOUR COLLISION REPAIR CENTER  
MANAGER AND COLLISION REPAIR TECHNICIANS**



# COLLISION REPAIR INFORMATION

## FOR THE COLLISION REPAIR PROFESSIONAL

TITLE: TOPCOAT SAND & POLISH  
SECTION: REFINISH BULLETIN #173  
MODELS: ALL TOYOTA, LEXUS, AND SCION  
DATE: APRIL 2009

---

Customers have high expectations for automotive paint finish appearance and expect repairs to match factory color, gloss, and texture. Flawed refinish appearance is a cause of concern and will likely have a negative affect on customer satisfaction and retention.

Toyota recognizes the reality of paint finish application in the shop environment. In addition to color matching and blending, countermeasures to remove paint process intrusion (dirt nibs) are necessary to achieve an undetectable finish match. This is also common in manufacturing plants when process intrusion is encountered. Countermeasures are defined as; ultra-fine sanding to level nibs followed by polishing to a level of gloss and texture consistent with the original finish. Technicians undertaking these tasks should review applicable technical data sheets for product process and handling instructions, as well as applicable safety information.

Topcoat sand and polish is one of many paint finish repair techniques covered in Toyota T101 and Lexus L101 Paint Finish Repair training. Please visit [www.crrtraining.com](http://www.crrtraining.com) for scheduling and registration information.



EXAMPLE IMAGES OF TOPCOAT ULTRA-FINE SANDING AND POLISHING TO REMOVE PROCESS INTRUSION DIRT NIBS - FACTORY AND BODY SHOP

**PLEASE ROUTE THIS BULLETIN TO YOUR COLLISION REPAIR CENTER  
MANAGER AND COLLISION REPAIR TECHNICIANS**



# COLLISION REPAIR INFORMATION

## FOR THE COLLISION REPAIR PROFESSIONAL

TITLE: WELDING ULTRA HIGH STRENGTH STEEL  
SECTION: STRUCTURAL BULLETIN #174  
MODELS: 2010 PRIUS -  
DATE: AUGUST 2009

---

Toyota has incorporated the use of Ultra High Strength Steel (UHSS) for rocker panel reinforcements in the body construction of the 2010 Prius. UHSS increases occupant cabin strength and rigidity. The strength rating for these UHSS components is 980 MPa (Mega Pascal), which has unique replacement welding requirements.

Welding specifications and steel strength ratings are documented in model-specific Collision Damage Repair Manuals. Because the use of UHSS is on the increase, always refer to vehicle-specific 'Structural Outlines' for locations of UHSS body components.

The following is an excerpt from repair manual recommendations on this topic.

#1: For welding 980 MPa Ultra High Strength Steel when two panels are joined.

Squeeze-Type Resistance Spot Welding	Pressure	294 daN (660 lbf)
	Weld Current	10,000 Amps
	Weld Time	16 Cycles (0.27 Seconds)
Gas Metal Arc/Metal Inert Gas Plug Welding	Hole Diameter	10 mm (0.39 in.)
	Wire Type	AWS A5.18 ER70S-3
	Shielding Gas	75-80% Argon - 25-20% CO2

#2: For plug welding 980 MPa Ultra High Strength Steel when two or more panels are joined.

Gas Metal Arc/Metal Inert Gas Plug Welding	Plug Diameter	10 mm (0.39 in.)
	Wire Type	AWS A5.18 ER70S-3
	Shielding Gas	75-80% Argon - 25-20% CO2

Since some variations may be necessary, consult STRSW technical manual and fine-tune welders with visual and destructive tests for specific application.

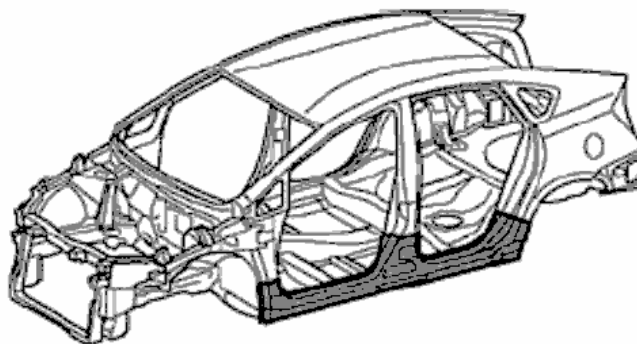

**PLEASE ROUTE THIS BULLETIN TO YOUR COLLISION REPAIR CENTER  
MANAGER AND COLLISION REPAIR TECHNICIANS**



# COLLISION REPAIR INFORMATION

## FOR THE COLLISION REPAIR PROFESSIONAL

TITLE: HSS & UHSS CABIN REINFORCEMENT REPAIR & REPLACEMENT  
SECTION: STRUCTURAL BULLETIN #175 (revised)  
MODELS: ALL TOYOTA, LEXUS, and SCION  
DATE: DECEMBER 2009

---

Model-specific 'Collision Damage Repair Manuals' contain 'Structural Outline' illustrations that identify locations and strength ratings for High Strength Steel (HSS) and Ultra High Strength Steel (UHSS) components throughout body and frame structures. This information is provided so that collision repair professionals can make informed decisions on repair and replacement of components that provide high margins of crash safety to vehicle occupants.

Because occupant safety is such a high priority, HSS and UHSS occupant cabin reinforcement repair is not recommended.

Do not use the following occupant cabin reinforcement repair procedures:

- Hot and cold straightening methods
- Sectioning of 980 MPa and 590 MPa strength-rated pillar reinforcements
- Sectioning of 440 MPa rated components at locations other than those specified

This recommendation is based on a reduction in reinforcement strength and crash energy management revealed during research and testing conducted by Toyota Motor Corporation. Repaired and/or improperly sectioned reinforcements failed to exhibit the strength and performance ratings of genuine new original equipment service parts installed to specification. Therefore damaged occupant cabin reinforcements must be replaced.

When reinforcements must be replaced always follow welding specifications and adhere to documented model-specific cut and join locations and procedures.

- Example Structural Outline -

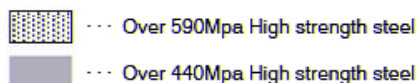
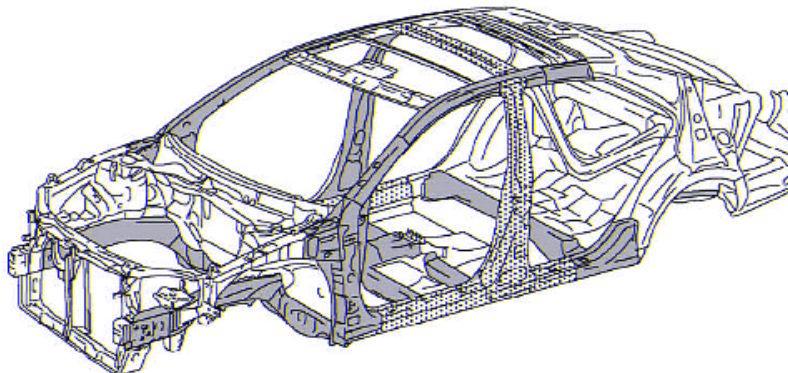

**PLEASE ROUTE THIS BULLETIN TO YOUR COLLISION REPAIR CENTER  
MANAGER AND COLLISION REPAIR TECHNICIANS**



# COLLISION REPAIR INFORMATION

## FOR THE COLLISION REPAIR PROFESSIONAL

TITLE: SRS OCCUPANT CLASSIFICATION SYSTEM INITIALIZATION  
SECTION: ELECTRICAL BULLETIN # 177  
MODELS: ALL EQUIPPED TOYOTA, LEXUS, and SCION MODELS  
DATE: MARCH 2010

---

Models equipped with a Supplemental Restraint System (SRS) Occupant Classification System (OCS) will enable or disable the passenger front and side airbags based on seat occupancy, passenger weight, and seat belt latch engagement.

If an equipped vehicle sustains collision damage, or if the front passenger seat or any of the OCS components are serviced, the SRS Malfunction Indicator Light (MIL) may illuminate setting a Diagnostic Trouble Code (DTC).

### NOTE:

**It is necessary to diagnose and repair the root cause of a SRS or OCS DTC before initializing the OCS system. If SRS and OCS DTC's are not cleared the system may not operate properly.**

Be sure to check and clear DTC's and perform OCS initialization per repair manual instructions with a Techstream Special Service Tool (SST) or capable diagnostic tester.



Any of the following conditions could set a DTC, illuminate the SRS MIL, or cause the PASSENGER AIRBAG light to indicate incorrectly, regardless of occupancy:

- The OCS Electronic Control Unit (ECU) is replaced
- Accessories such as a seatback tray are installed on the passenger seat
- The passenger seat is removed and replaced or reinstalled
- The vehicle is involved in an accident or collision

Model-specific repair manuals can be accessed through the Technical Information System (TIS) [www.techinfo.toyota.com](http://www.techinfo.toyota.com).

**PLEASE ROUTE THIS BULLETIN TO YOUR COLLISION REPAIR CENTER  
MANAGER AND COLLISION REPAIR TECHNICIANS**



# COLLISION REPAIR INFORMATION

## FOR THE COLLISION REPAIR PROFESSIONAL

TITLE: USE OF NON-OEM PARTS ON TOYOTA VEHICLES  
SECTION: EXTERIOR BULLETIN # 180  
MODELS: ALL TOYOTA, LEXUS, and SCION VEHICLES  
DATE: DECEMBER 2010

---

Toyota Lexus and Scion vehicles are engineered and manufactured as an integrated assembly of carefully designed and manufactured parts working as a system to provide predictable performance, safety and durability.

To help preserve the performance of Toyota/Lexus/Scion vehicles, Toyota Scion and Lexus publishes detailed repair procedures and produces and sells Genuine Toyota/Lexus Parts, which are manufactured to the same specifications and tolerances as the parts installed on new Toyota, Lexus and Scion vehicles. Repairing a vehicle using Genuine Toyota/Lexus/Scion parts and procedures can help return Toyota vehicles to pre-loss condition following a collision.

### **The use of Alternative Parts**

Due to the sensitive nature of the safety and performance systems and lack of testing to determine their effect on vehicle crashworthiness, Toyota, Lexus and Scion do not recommend the use of alternative parts for the repair of Toyota vehicles. This includes:

- **Aftermarket Parts:** Parts manufactured and branded by a company other than Toyota, Scion or Lexus
- **Rebuilt Parts:** Exterior sheet metal parts (including bumpers and wheels) removed from a damaged Toyota, Lexus or Scion vehicle and refurbished for re-sale
- **Salvage/Recycled Parts:** Parts removed from a previously damaged vehicle, cleaned up and then installed on a different vehicle.

### **Overall Body Structure**

Genuine Toyota, Lexus and Scion Parts are constructed using metals with specific properties, thicknesses and stamping structures built to perform in a consistent and predictable way during a collision event. The use of non-OEM structural components may compromise the overall crashworthiness and occupant safety of Toyota, Lexus or Scion vehicles in a subsequent collision.

**PLEASE ROUTE THIS BULLETIN TO YOUR COLLISION REPAIR CENTER  
MANAGER AND COLLISION REPAIR TECHNICIANS**





### **Supplementary Restraint System (SRS) Components**

Toyota, Lexus and Scion vehicles are equipped with several SRS components including airbags and seatbelt pretensioners, which are designed to help protect vehicle occupants from injury. These parts rely upon precisely manufactured sensors to detect a collision event and trigger the SRS components to deploy within milliseconds of an impact. The installation of parts branded by companies other than Toyota, Scion or Lexus that may not be tested to match Toyota, Lexus or Scion performance specifications may alter the structure of a vehicle and could result in improper operation of the SRS sensors and components.

### **Exterior Sheet Metal Parts**

The exterior sheet metal components are often described as “Cosmetic Parts”. However, these parts are designed and tested as part of the overall vehicle and may help send impact energy to the SRS sensors. In addition, some of these parts may help Toyota, Lexus or Scion vehicles comply with several Federal Motor Vehicle Safety Standards (FMVSS) including hood intrusion in the passenger cabin, preservation of proper door operation following a collision and proper airbag function. Alternative parts may not be crash tested to verify compliance with these standards.

### **Recycled Parts**

Toyota, Lexus and Scion do not recommend the re-use of structural components that have been removed from a previously damaged vehicle. Although parts may appear equivalent, it may be difficult to identify previous damage, if a part has received collateral damage as a result of a prior collision or if the part has been subject to extreme weathering, corrosion or other detrimental environmental exposure. Furthermore, removing welded parts from a donor vehicle, may compromise the structural integrity of the parts being used.

**PLEASE ROUTE THIS BULLETIN TO YOUR COLLISION REPAIR CENTER  
MANAGER AND COLLISION REPAIR TECHNICIANS**



# Structural Repair Position Statements – Volkswagon

1. Vehicle Body Sectioning – November 2008
  2. Supplemental Restraint System Wiring Harnesses – November 2008
  3. Supplemental Restraint System Airbag Component Replacement – November 2008
  4. Refinish Procedures for Clearcoat Application – November 2008
  5. Radiator Core Support – August 2009
  6. Wheel Repair and Reconditioning – November 2008
-



# Volkswagen COLLISION REPAIR STANDARDS

## Vehicle Body Sectioning

*Applicable to All Volkswagen Models*

Volkswagen designs and equips their vehicles with the latest crashworthy features to help ensure optimum occupant safety. In maintaining these standards, Volkswagen is providing collision repair centers with critical information pertaining to collision repair/parts replacement on Volkswagen vehicles.

Full body sectioning (sometimes referred to as “clipping”) is a method of repairing vehicles that have been involved in severe rear collisions. The repair is performed by welding the rear portion of a salvage vehicle to the vehicle which sustained the damage.

**NOTE: Full body sectioning is not an acceptable method of repair on any Volkswagen vehicle. This is based on the following information pertaining to full body sectioning:**

- Presents repair issues with regard to fit, finish, vehicle alignment, functionality, and reliability.
- Does not meet Volkswagen standards for corrosion protection and construction.
- Decreases the strength and safety of the original vehicle design.
- Increases vehicle noise, vibration, and harshness and the risk of water leaks.
- Raises concerns about warranty and quality and may depreciate the value of the vehicle.
- Not covered under Volkswagen’s new vehicle limited warranty.
- Damage to or failure of a Volkswagen part caused by this repair procedure or improper performance is not covered under Volkswagen’s new vehicle limited warranty.

**This Volkswagen repair statement is not limited to body sectioning but also includes the use of salvaged frame rails for repair of damaged vehicles.**

Full body sectioning is not a procedure approved by Volkswagen and therefore does not meet Volkswagen’s safety specifications, putting the vehicle occupants and other drivers at risk in the event of a future collision.

The only proper method of repair is to use genuine Volkswagen sheet metal replacement parts for severely damaged unitized metal frame constructed vehicles.

PLEASE DISTRIBUTE THIS DOCUMENT TO THE FOLLOWING: COLLISION REPAIR CENTER MANAGERS, ESTIMATORS, AND TECHNICIANS.

**The right part. The right fit. The right price.**

Genuine Volkswagen Parts have the same fit, finish, and quality as original parts. They make your job easier and your customers happier.



# Volkswagen COLLISION REPAIR STANDARDS

## Supplemental Restraint System Wiring Harnesses

*Applicable to All Volkswagen Models*

Volkswagen designs and equips their vehicles with the latest crashworthy features to help ensure optimum occupant safety. In maintaining these standards, Volkswagen is providing collision repair centers with critical information pertaining to collision repair/parts replacement on Volkswagen vehicles.

Damaged Supplemental Restraint System (SRS) wiring or wiring connectors require replacement of the wiring harness. **It is necessary to follow all precautions and replacement procedures found in the Volkswagen model-specific repair manual for SRS wiring and wiring components.**

Any SRS wiring, wiring connectors, or wiring harnesses near the area of collision damage should be thoroughly examined.

**Volkswagen approves only repairs made with Genuine Volkswagen Parts. Aftermarket, salvage, or remanufactured SRS airbag system parts do not meet the exacting specifications of Genuine Volkswagen Parts and therefore are not an acceptable method of repair on any Volkswagen vehicle.** These parts may depreciate the value of the vehicle and/or put the vehicle occupants at risk. Aftermarket, salvage, and remanufactured parts or failure of another Volkswagen part caused by the installation or improper performance of an aftermarket, salvage, or remanufactured part is not covered under Volkswagen's new vehicle limited warranty.

**NOTE: Do NOT attempt to repair the SRS wiring system or related components on any Volkswagen vehicle. Replace any damaged or bent SRS components with Genuine Volkswagen Parts. Some fasteners and clips are non-reusable; refer to the Volkswagen repair manual for more information.**

PLEASE DISTRIBUTE THIS DOCUMENT TO THE FOLLOWING: COLLISION REPAIR CENTER MANAGERS, ESTIMATORS, AND TECHNICIANS.

**The right part. The right fit. The right price.**

Genuine Volkswagen Parts have the same fit, finish, and quality as original parts. They make your job easier and your customers happier.



# Volkswagen COLLISION REPAIR STANDARDS

## Supplemental Restraint System Airbag Component Replacement

*Applicable to All Volkswagen Models*

Volkswagen designs and equips their vehicles with the latest crashworthy features to help ensure optimum occupant safety. In maintaining these standards, Volkswagen is providing collision repair centers with critical information pertaining to collision repair/parts replacement on Volkswagen vehicles.

The Supplemental Restraint System (SRS) is a critical component of all Volkswagen vehicles' safety belt systems; it provides additional protection to vehicle occupants in the event of a frontal or side impact collision.

After a vehicle has been involved in a collision, certain components of the SRS airbag system must be replaced. This is a significant part of the vehicle repair as all Volkswagen vehicles are precisely engineered to exacting specifications in order to help protect occupant safety; all components of the SRS airbag system must be restored to a pre-accident condition in order to protect the occupants in the event of subsequent accident. **Technicians must always refer to the Volkswagen repair manual to determine which components must be inspected, tested, or replaced following a collision of any Volkswagen vehicle.**

**Volkswagen approves only repairs made with Genuine Volkswagen Parts. Aftermarket, salvage, or remanufactured SRS airbag system parts do not meet the exacting specifications of Genuine Volkswagen Parts and therefore are not an acceptable method of repair on any Volkswagen vehicle.** These parts may depreciate the value of the vehicle and/or put the vehicle occupants at risk. Aftermarket, salvage, and remanufactured parts or failure of another Volkswagen part caused by the installation or improper performance of an aftermarket, salvage, or remanufactured part is not covered under Volkswagen's new vehicle limited warranty.

**Even in minor collision impacts where the SRS airbag does not deploy, various components must be thoroughly inspected for damage. Refer to the Volkswagen repair manual for the correct diagnostic, repair, and replacement procedures.**

PLEASE DISTRIBUTE THIS DOCUMENT TO THE FOLLOWING: COLLISION REPAIR CENTER MANAGERS, ESTIMATORS, AND TECHNICIANS.

**The right part. The right fit. The right price.**

Genuine Volkswagen Parts have the same fit, finish, and quality as original parts. They make your job easier and your customers happier.



# Volkswagen COLLISION REPAIR STANDARDS

## Refinish Procedures for Clearcoat Application

*Applicable to All Volkswagen Models*

Volkswagen continually enhances vehicle styling which includes precise aerodynamic designs and the highest quality paintwork. In order to maintaining these factory engineered standards, Volkswagen is providing collision repair centers with critical information pertaining to collision repair/parts replacement on Volkswagen vehicles.

“Solvent blending” is a method that in the past was commonly used to blend within an exterior body panel. This type of repair procedure cannot be used on the OEM applied finishes on vehicles today. The reason is simple; the bond between the OEM finish and the newly applied refinish paint cannot “blend” or “melt” into one another.

Additionally, the following problems are directly related to “solvent blending”:

- Lack of adhesion and/or delamination of the OEM finish and the refinish coating.
- Visible paint lines and defects are caused by polishing, buffing, or detailing a thin “solvent blended” area.
- “Solvent blending” products are not recommended or guaranteed by the paint companies that manufacture them. For a paint manufacturer guarantee, clearcoat must always be sprayed to the edge of the panel.
- “Solvent blending” products are volatile organic compounds (VOCs). Many states have established regulations prohibiting the use of VOCs.

**NOTE: “Solvent blending” is not an acceptable method of repair on any Volkswagen vehicle.**

Volkswagen recommends the following procedure for refinishing exterior body panels in order to restore the vehicle to a pre-accident condition; this procedure is based on Volkswagen’s concern about our customers as well as our environmental responsibility.

- Remove moldings from the subject panel as well as any adjacent panel.
- Mask the vehicle as usual to prevent overspray.
- Chemically clean the vehicle prior to any spray application.
- Sand/prep panel appropriately based on paint manufacturer’s recommendations.
- Apply base color coat to the repair area only.
- Spray into the adjacent panel as necessary for an undetectable color match.
- Apply the first coat of urethane clearcoat to the repair area only.
- For a two clearcoat system, spray only the second coat to the end of the panel.
- For a three clearcoat system, spray only the final coat to the end of the panel.

Spraying the final full coat of urethane clear insures maximum adhesion, ultra-violet sunlight protection and is environmentally safer. Over-reducing clearcoat, which is required during the “solvent blending” process, does not provide the same level of surface film build in order to provide a high quality repair.

PLEASE DISTRIBUTE THIS DOCUMENT TO THE FOLLOWING: COLLISION REPAIR CENTER MANAGERS, ESTIMATORS, AND TECHNICIANS.

**The right part. The right fit. The right price.**

Genuine Volkswagen Parts have the same fit, finish, and quality as original parts. They make your job easier and your customers happier.



# Volkswagen COLLISION REPAIR STANDARDS

## Radiator Core Support

*Applicable to All Volkswagen Models*

Volkswagen is pleased to provide collision repair centers with the following information pertaining to collision repair/parts replacement on Volkswagen vehicles.

Repairing a radiator core support is a process by which dent(s) or crack(s) are repaired to eliminate collision damage; this process may include heating, filling, welding, or reshaping.

**NOTE: Repaired radiator core supports may not meet the exacting specifications of genuine Volkswagen parts. Therefore, these supports may not be used on Volkswagen vehicle. This includes any steel, aluminum, or composite radiator core supports that are bolted and/or welded to the vehicle.**

**Volkswagen radiator core supports are structural. Repaired radiator core supports or any radiator core supports not approved by Volkswagen may cause unsafe vehicle performance in the event of a subsequent collision.**

PLEASE DISTRIBUTE THIS DOCUMENT TO THE FOLLOWING: COLLISION REPAIR CENTER MANAGERS, ESTIMATORS, AND TECHNICIANS.

**The right part. The right fit. The right price.**

Genuine Volkswagen Parts have the same fit, finish, and quality as original parts. They make your job easier and your customers happier.

Aug 2009



# Volkswagen COLLISION REPAIR STANDARDS

## Wheel Repair and Reconditioning

*Applicable to All Volkswagen Models*

Volkswagen designs and equips their vehicles with the latest crashworthy features to help ensure optimum occupant safety. In maintaining these standards, Volkswagen is providing collision repair centers with critical information pertaining to collision repair/parts replacement on Volkswagen vehicles.

Wheel reconditioning is a repair process by which a collision damaged wheel surface is repaired to eliminate collision damage; this process may include heating, filling, straightening, welding, removing wheel substance, reshaping, or re-plating.\*

**NOTE: Reconditioned wheels do not meet the exacting specifications of genuine Volkswagen wheels and therefore are not an acceptable method of repair on any Volkswagen vehicle.**

**A reconditioned wheel or any wheel not approved by Volkswagen may cause unsafe vehicle operation, including loss of control which may result in injury or death of the vehicle occupants or other drivers.**

Volkswagen approves only wheel repairs which are limited to surface sanding and cosmetic refinishing processes that remove and replace only paint coatings. Any wheel near the area of collision damage should be thoroughly examined to ensure that the wheel meets the original safety specifications.

PLEASE DISTRIBUTE THIS DOCUMENT TO THE FOLLOWING: COLLISION REPAIR CENTER MANAGERS, ESTIMATORS, AND TECHNICIANS.

*NOTE: The Code of Federal Regulations, U.S. Department of Transportation, contains section 570.10 regarding Wheel Assemblies. Based on section (a) Wheel integrity, state governments which have mandatory vehicle safety inspections **require that vehicle wheels do not have any indication of repair by welding.***

**The right part. The right fit. The right price.**

Genuine Volkswagen Parts have the same fit, finish, and quality as original parts. They make your job easier and your customers happier.